



Department of Purchasing and Contracting

Maloo Administration Building, 1300 Commerce Drive, 2nd Floor, Decatur, Georgia 30030

November 2, 2020

INVITATION TO BID (ITB) NO. 20-101299

FOR

TENNIS COURTS REPAIR AND REPLACEMENT

DEKALB COUNTY, GEORGIA

Procurement Agent: Jennifer Schofield
Phone: 404.687.4042
Email: jjschofield@dekalbcountyga.gov
Mandatory DeKalb First LSBE Meeting: November 4, 2020, November 12, 2020
Deadline for Submission of Questions: 5:00 P.M. ET, November 24, 2020
Bid Opening: 3:00 P.M. ET, December 7, 2020
Price Schedule Opening: 3-5 days after Opening

Form with fields for FIRM'S NAME AND ADDRESS, TELEPHONE AND FAX NUMBERS WITH AREA CODE, Federal Tax ID No., ARE YOU A DEKALB COUNTY FIRM?, SIGNATURE OF PERSON AUTHORIZED TO SIGN BID AND DATE, and SIGNER'S NAME AND TITLE (Type of Print):

THE RESPONSIBILITY FOR SUBMITTING A RESPONSE TO THIS BID TO THE DEPARTMENT OF PURCHASING AND CONTRACTING OF DEKALB COUNTY GOVERNMENT ON OR BEFORE THE STATED DATE AND TIME WILL BE SOLELY AND STRICTLY THE RESPONSIBILITY OF THE BIDDER.



TABLE OF CONTENTS

FOR

INVITATION TO BID NO. 20-101299

<u>TITLE</u>	<u>PAGE NO.</u>
INVITATION TO BID OVERVIEW.....	3
INVITATION TO BID PROCEDURES.....	4
GENERAL TERMS AND CONDITIONS	8
MINIMUM SPECIFICATIONS	18
ATTACHMENT A PRICE SCHEDULE	20
ATTACHMENT B BID ACKNOWLEDGEMENT FORM.....	43
ATTACHMENT C CONTRACTOR REFERENCE AND RELEASE FORM.....	44
ATTACHMENT D SUBCONTRACTOR REFERENCE AND RELEASE FORM	45
ATTACHMENT E CONTRACTOR & SUBCONTRACTOR EVIDENCE OF COMPLIANCE:	46
ATTACHMENT F CONTRACTOR AFFIDAVIT	47
ATTACHMENT G SUBCONTRACTOR AFFIDAVIT.....	48
ATTACHMENT H DEKALB FIRST LSBE INFORMATION WITH EXHIBITS A – B	49
EXHIBIT A SCHEDULE OF DEKALB FIRST LOCAL SMALL BUSINESS ENTERPRISE PARTICIPATION OPPORTUNITY TRACKING FORM.....	51
EXHIBIT A DEKALB COUNTY CHECKLIST FOR GOOD FAITH EFFORTS	53
EXHIBIT A, BIDDER/PROPOSER STATEMENT OF COMPLIANCE	55
EXHIBIT B LETTER OF INTENT TO PERFORM AS A SUBCONTRACTOR	57
ATTACHMENT I FIRST SOURCE JOBS ORDINANCE INFORMATION (WITH EXHIBITS 1 – 4).....	58
EXHIBIT 1 First Source Jobs Ordinance Acknowledgement.....	58
EXHIBIT 2 NEW EMPLOYEE TRACKING FORM.....	59
EXHIBIT 3 BUSINESS SERVICE REQUEST FORM.....	60
EXHIBIT 4 EMPLOYMENT ROSTER.....	61
ATTACHMENT J SITE VISIT ACKNOWLEDGEMENT	62
ATTACHMENT K REQUIRED DOCUMENTS CHECKLIST.....	63



INVITATION TO BID OVERVIEW

A. PURPOSE:

DeKalb County Government (the County) is soliciting bids for **20-101299, Tennis Courts Repair and Replacement** from responsible bidders.

B. GENERAL INFORMATION:

1. BID TIMETABLE:

The anticipated schedule for the bid process is as follows:

Date Issued:	November 2, 2020
Mandatory DeKalb First LSBE Meeting: (Bidders must attend 1 meeting on either of the dates listed.)	November 4, 2020, November 12, 2020 4572 Memorial Drive, Decatur, Georgia 30032 Main Conference Room - A (Meetings are held at 10:00 a.m. and 2:00 p.m.)
Deadline for Submission of Questions:	5:00 P.M. ET, November 24, 2020
Bid Opening:	<u>3:00 P.M. ET, December 7, 2020</u>
Price Schedule Opening:	3-5 Business Days After Opening
Bids Valid Until:	Bids shall be valid for 90 days from and including the bid opening date.

Sealed bids are to be addressed and delivered to:

DeKalb County Department of Purchasing and Contracting
Maloof Administration Building
1300 Commerce Drive, 2nd Floor
Decatur, Georgia 30030, not later than **3:00 P.M. ET, November 24, 2020**

*****NEW-PRICE SCHEDULE MUST BE SUBMITTED IN A SEPARATE SEALED ENVELOPE OR BIDDER WILL BE DEEMED NON-RESPONSIVE AND WILL NOT BE CONSIDERED FOR AWARD*****

Submit **one original bid package** (inclusive of the entire Invitation to Bid document and required documents with the exception of the price schedule) stamped “Original” and **two sealed identical copies** stamped “Copy” of the bid package to the address listed above.

2. CONTACT PERSON:

The contact person for this bid is **Jennifer Schofield, Procurement Agent**. General inquiries concerning the meaning or interpretation of this Invitation to Bid (ITB) may be requested from the contact person via email at jjshofield@dekalbcountyga.gov. Questions and requests for information or clarification concerning the specifications in this ITB must be submitted to the above listed contact person via email no later than the date and time listed in the bid timetable. Questions and requests received after the above stated time or sent to anyone other than the listed contact person will not receive a response or be the subject of addenda.

3. QUESTIONS:

All requests must be in writing. Any explanation desired by a bidder regarding the meaning or interpretation of the Invitation to Bid, drawings, specifications, requirements, etc., must be requested in writing and with sufficient time allowed for a reply to reach bidders before the submission of their bids. If any statement in the bidding documents, specifications, plans, etc., appear ambiguous to the Bidder, Bidder is specifically instructed to make a written request to the Department of Purchasing and Contracting as outlined *in* the preceding sentence. Any information given to a prospective bidder concerning an Invitation to Bid will be furnished to all prospective bidders, as an addenda to the Invitation, if such information is necessary to bidders in submitting bids on the Invitation or if the lack of such information would be prejudicial to uninformed bidders. Oral explanations or instructions given before the award of the contract will not be binding. **Questions must be submitted no later than 5:00 pm EST on November 24, 2020.**

4. ADDITIONAL INFORMATION/ADDENDA:

The County will issue responses to inquiries and any other corrections or amendments it deems necessary in written addenda issued prior to the bid opening date. Bidders should not rely on any representations, statements or explanations other than those made in this ITB or in any addendum to this ITB. Where there appears to be a conflict between the ITB and any addenda issued, the last addendum issued will prevail. It is the responsibility of the Bidder to ensure awareness of all addenda issued for this solicitation. Please acknowledge the addenda and submit to the DeKalb County Department of Purchasing and Contracting as requested. Bidders may contact the above listed contact person to verify the number of addenda prior to submission. Addenda issued for this ITB will be posted on DeKalb County's website, http://www.dekalbcountyga.gov/purchasing/pc_index_formal_solicitations.html. Bidder should regularly check the County's website for addenda.

INVITATION TO BID PROCEDURES

A. BIDDER INFORMATION:

- 1. FAILURE TO SUBMIT THE PRICE SCHEDULE IN A SEPARATE SEALED ENVELOPE SHALL DEEM THE BID NON-RESPONSIVE. INCLUDING THE PRICE SCHEDULE IN ANY AREA OUTSIDE OF ITS SEPARATE, SEALED ENVELOPE WILL RESULT IN BIDDER'S BID BEING DEEMED NON-RESPONSIVE.**
2. Failure to return all pages of this Invitation to Bid may result in bid being deemed non-responsive.
3. Minimum specifications are intended to be open and non-restrictive. Contractors are invited to inform the DeKalb County Department of Purchasing and Contracting whenever specifications or procedures appear not to be fair and open. Such information should be supplied as early in the procurement process as possible. Information received in less than five (5) days prior to the

scheduled bid opening will not be acted upon unless the DeKalb County Department of Purchasing and Contracting rules that it is in the best interest of the County to consider.

4. Brand names and numbers when provided in solicitations are for reference and to establish a quality standard. Any reference to a brand name shall not be construed as restricting Bidders to that manufacturer (unless “no substitutes” is stated). Bids on equal items will be considered, provided the bid clearly describes the article offered and it is equal or better in quality and function and fully compatible with this requirement.
5. By submitting a bid, Bidder warrants that any goods or services supplied to DeKalb County Government meet or exceed the specifications set forth in this solicitation.
6. If any supplies, materials, and equipment are provided to the County under this solicitation, then such items shall be new and in first-class condition unless the solicitation specifically allows offers of used, reconditioned, or remanufactured items. If newly manufactured products are specified, such products shall be of recent origin and not previously used. No equipment of any type is acceptable if serial numbers or any other manufacturer’s identification labels or marks have been removed, obliterated, or changed in any way. A Contractor delivering any such equipment to the County will be deemed to have breached the contract and appropriate action will be taken by the DeKalb County Government Purchasing and Contracting Department.
7. Time of delivery is a part of the solicitation and an element of the contract that is to be awarded. If the Bidder cannot meet the required service delivery dates, a bid should not be submitted. Failure to deliver in accordance with the contract could result in the Contractor being declared in default.
8. **Bid Withdrawal**
Bids may be withdrawn at any time prior to the bid opening. After bids have been publicly opened, withdrawal of bids shall be based upon Part 3, Section IV, F. within the DeKalb County Purchasing Policy.
9. **Expenses of Preparing Responses to this ITB**
The County accepts no responsibility for any expenses incurred by Bidders who submit bids in response to this ITB. Such expenses are to be borne exclusively by the Bidders.
10. It is the responsibility of each Bidder to ensure that its submission is received by 3:00 p.m. on the bid due date. The time/date stamp clock located in the Department of Purchasing & Contracting shall serve as the official authority to determine lateness of any bid. The bid opening time shall be strictly observed. Be aware that visitors to our offices will go through a security screening process upon entering the building. Bidders should plan enough time to ensure that they will be able to deliver their submission prior to our deadline. Late submissions, for whatever reason, will not be evaluated. Bidders should plan their deliveries accordingly. Telephone or fax bids will not be accepted.
11. Price Schedule openings shall be conducted in the Department of Purchasing and Contracting three (3) to five (5) days after the bid opening. Only the Price Schedules of responsive bidders shall be opened. The County reserves the right to decide which bid(s) will be deemed responsive and said determination shall be made in accordance with the requirements stated in this solicitation.

12. Federal Work Authorization

Pursuant to O.C.G.A. §13-10-91, the County cannot enter into a contract for the physical performance of services unless the Contractor, its Subcontractor(s) and sub-subcontractor(s), as that term is defined by state law, register and participate in the Federal Work Authorization Program to verify specific information on all new employees. The Bidder certifies that he/she has complied and will continue to comply throughout the contract term with O.C.G.A. §13-10-91 and any related and applicable Georgia Department of Labor Rule. Contractor agrees that in the event it employs or contracts with any Subcontractor(s) in connection with this contract, Contractor will secure from each Subcontractor an affidavit that certifies the Subcontractor's current and continuing compliance with O.C.G.A. §13-10-91 throughout the contract term. Each Subcontractor agrees that in the event it employs or contracts with any sub-subcontractor(s), each Subcontractor will secure from each sub-subcontractor an affidavit that certifies the sub-subcontractor's current and continuing compliance with O.C.G.A. §13-10-91 throughout the contract term.

13. LSBE Information

- a. It is the objective of the Chief Executive Officer and Board of Commissioners of DeKalb County to provide maximum practicable opportunity for all businesses to participate in the performance of government contracts. The current DeKalb County List of Certified Vendors may be found on the County website at <http://www.dekalbcountyga.gov/purchasing/pdf/supplierList.pdf>
- b. It is required that all responding Bidders attend the mandatory LSBE meeting within two-weeks of the solicitation's advertisement, and comply, complete and submit all LSBE forms with the Bidder's response in order to remain responsive. Attendance can be in person, via video conference and teleconference. Video conferencing is available through Skype/Lync. Instructions for attendance via video conference can be found on the County's website at <https://www.dekalbcountyga.gov/purchasing-contracting/dekalb-first-lsbe-program>.
- c. For further details regarding the DeKalb First Local Small Business Enterprise Ordinance, contact our LSBE Program representatives, at DeKalbFirstLSBE@dekalbcountyga.gov or (404) 371-4770.

14. First Source Jobs Information

The DeKalb County First Source Jobs Ordinance requires contractors or beneficiaries entering into any type of agreement with the County, including purchase orders, regardless of what they may be called for the procurement or disposal of supplies, services, construction projects, professional or consultant services, which is funded in whole or part with County funds or County administered funds in which the contractor is to receive \$50,000 or more in County expenditures or committed expenditures and recipient of urban redevelopment action grants or community development block funds administered in the amount of \$50,000 or more make a good faith effort to hire DeKalb County residents for at least 50% of jobs using the First Source Registry (candidate database). The work to be performed under this contract is subject to the provisions of the DeKalb County First Source Jobs Ordinance.

For more information on the First Source Jobs Ordinance requirement, please contact WorkSource DeKalb at www.dekalbworkforce.org or 404-687-3400.

15. Attention to General Terms and Conditions

Bidders are cautioned to thoroughly understand and comply with all matters covered under the General Terms and Conditions section of this ITB. The successful Bidder(s) will enter into a contract approved by the County. The County's ITB document and attachments, subsequent County addenda, and the Bidder's response documents are intended to be incorporated into a contract. All Bidders should thoroughly review this document prior to submitting a bid. Any proposed revisions to the terms or language of this document must be submitted in writing with the bid. Since proposed revisions may result in a bid being rejected if the revisions are unacceptable to the County, bidders should review any proposed revisions with an officer of the firm having authority to execute the contract. No alterations can be made in the contract after award is made.

16. Required Signatures

Bids must be signed by an officer or agent of the firm having the authority to execute contracts.

17. Ethics Rules

Bidders are subject to the Ethics provision within the DeKalb County Purchasing Policy; the Organizational Act, Section 22A, the Code of DeKalb County; and the rules of Executive Order 2014-4. Any violations will be addressed, pursuant to these policies and rules.

To the extent that the Organizational Act, Section 22A, the Code of DeKalb County, and the rules of Executive Order 2014-4 allow a gift, meal, travel expense, ticket, or anything else of value to be purchased for a CEO employee by a contractor doing business with the County, the contractor must provide written disclosure, quarterly, of the exact nature and value of the purchase to the Chief Integrity Officer, if created, or the Finance Director or his/her designee. Every contractor conducting business with the County will receive a copy of these ethical rules at the time of execution of the contract.

18. Business License

Bidders shall submit a copy of its current, valid business license with its Bid or upon award. Georgia companies are to submit a valid county or city business license. Contractors that are not Georgia companies are to provide a certificate of authority to transact business in the State of Georgia and a copy of a valid business license issued by its home jurisdiction. If Bidder holds a professional certification which is licensed by the state of Georgia, then Bidder may submit a copy of its valid professional license with Bidder's bid or upon award unless the Minimum Specifications require submittal with the bid. Any license submitted in response to this ITB shall be maintained by the Contractor for the duration of the contract.

B. BID SUBMITTAL:

1. All bids should be completed in ink or typewritten. Errors should be crossed out and corrections entered in ink or typewritten adjacent to the error. The person signing the bid should initial corrections in ink.
2. Bidders shall complete and submit Attachment A - Required Documents Checklist and all documents responsive to this requirement with the bid submittal.
3. If applicable, provide evidence that the Bidder is a DeKalb County Firm.
4. Bids must be submitted in a sealed envelope(s) or box(es) with the Bidder's name and "20-101299,

Tennis Courts Repair and Replacement” on the outside of each envelope or box. All Bidders delivering submittals via delivery services, please place the sealed bid envelope(s) or box(es) inside the delivery service envelope(s) or box(es). Bidders are responsible for informing any delivery service of all delivery requirements. No responsibility shall attach to the County for the premature opening of a submission not properly addressed and/or identified. The Decatur postmaster will not deliver certified or special delivery mail to specific addresses within DeKalb County Government.

C. CONTRACT AWARD:

1. Bids submitted will be evaluated and recommended for award to the lowest, responsive, and responsible Bidder(s).
2. The intent of this bid is to make an all-award; however, the County reserves the right to award by line item or multiple awards. The County may accept any item or group of items on any bid, whichever is in the best interest of DeKalb County.
3. The County reserves the right to reject any and all bids, to waive informalities, and to re-advertise.
4. The judgment of DeKalb County Purchasing and Contracting on matters, as stated above, shall be final. The County reserves the right to decide which Bid will be deemed lowest, responsive and responsible.

GENERAL TERMS AND CONDITIONS

- A.** In the event of a conflict between any provisions contained in any of the documents governing this transaction, the following shall be the order of precedence: Change Orders or modifications; the Bidder’s accepted bid; and the County’s ITB.
- B.** The Bidder’s services shall include all things, personnel, and materials necessary to provide the goods or services that are in compliance with the specifications as authorized by the County.

C. DELIVERY:

1. Delivery of services or goods will commence within ten (10) days of the Notice To Proceed.

Bidder state agreement: Yes _____ No _____

Contact Person: _____

Telephone Number: _____ Cellular Phone Number: _____

Address: _____

Alternate delivery time may be considered provided it is so stated. Bidder state alternate terms for delivery or services below.

-
-
2. All prices are to be firm, F.O.B. Destination, Freight Prepaid and Allowed. This shall include delivered, unloaded, and placed in designated place. Delivery must be made between 9:00 A.M. and 2:30 P.M. Monday through Friday, unless otherwise required..

D. FOREIGN PRODUCTS:

DeKalb County prefers to buy items produced and/or manufactured in the United States of America; however, foreign products may be considered provided it is so stated. Bidder certifies that items offered on this bid is/are manufactured and produced in the United States.

Yes _____ No _____

If "No", state the exact location of plant or facility where items will be produced:

E. WARRANTY AND/OR GUARANTY:

The bidder will state below or will furnish a separate letter attachment, which fully explains the conditions of Warranty and/or Guaranty in compliance with the Warranty conditions specified in the Scope of Work. If no Warranty and/or Guaranty are applicable, it must be so stated. **NOTE:** FAILURE TO RESPOND TO THE REQUIREMENTS OF THIS PARAGRAPH MAY RESULT IN THE BID BEING DEEMED NON-RESPONSIVE.

F. SAMPLES & TESTING:

Samples of items, when required, must be submitted within the time specified, and unless otherwise specified by the County, at no expense to the County. If not destroyed by testing, samples will be returned at bidder's request and expense, unless otherwise specified by the Invitation to Bid. Since tests may require several days for completion, the County reserves the right to use a portion of any supplies before the results of the tests are known, without prejudice to any final adjustments, rejecting the unused portion of the delivery and payment will be made on an adjusted basis for the used portion. The costs of inspections and tests of any item which fails to meet the advertised specifications shall be borne by the bidder.

G. LITERATURE:

When the bidder proposes to furnish another product, he is required to furnish, with his bid, literature describing the item(s) being offered. Failure to furnish this literature may result in the bid being deemed non-responsive.

H. SILENCE OF SPECIFICATIONS:

The apparent silence of these specifications and any supplemental specifications as to any details, or the omission from it of a detailed description concerning any point, shall be regarded as meaning that only the best commercial practices are to prevail and that only materials of first quality and correct type, size and design are to be used. All workmanship is to be first quality. All interpretations of this specification shall be made upon the basis of this statement, with County interpretation to prevail.

I. TERM:

The Contractor shall commence the Work under this Contract within ten (10) days from the acknowledgement of receipt of the Notice to Proceed (“Commencement Date”). The Initial Term of this Agreement shall be for twelve (12) calendar months, beginning on the Commencement Date.

J. PRICING:

1. Alterations to the Price Schedule may result in the Bidder being deemed non-responsive and its bid may be rejected.
2. By submission of this bid, the bidder certifies, and in the case of a joint bid each party thereto certifies as to its own organization that in connection with this procurement:
 - a. the prices in this bid have been arrived at independently, without consultation, communication, or agreement, for the purpose of restricting competition, as to any matter relating to such prices with any other bidder or with any competitor;
 - b. Unless otherwise required by law, the prices which have been quoted in this bid have not been knowingly disclosed by the bidder and will not knowingly be disclosed by the bidder prior to opening, directly or indirectly to any other bidder or to any competitor; and
 - c. No attempt has been made or will be made by the bidder to induce any other person or firm to submit or not to submit a bid for the purpose of restricting competition.

K. PAYMENT:

1. The County shall pay the Contractor based upon the accepted bid prices submitted by Bidder. Invoices should be signed by the Bidder or authorized delegate and must contain the authorizing DeKalb County Purchase Order (PO) and/or Contract Purchase Agreement (CPA) Number in order for payment to be processed. PO Number must also be on the delivery ticket.

A Contract Purchase Agreement is being issued in lieu of a formal contract. Any reference to a contract refers to the CPA.

2. Invoice(s) must be submitted as follows:

a. Original invoice(s) must be submitted to the department requesting services.

DeKalb County Government
Recreation, Parks and Cultural Affairs
3681 Chestnut Street
Scottsdale, GA 30079
Attn: Paige Singer

b. Upon award, Prime Contractor(s) with Local Small Business Enterprise (LSBE) Subcontractor(s) shall enter utilization reports electronically at www.dekalbblsbe.info. Proof of payment to the LSBE Subcontractor must be uploaded and submitted. LSBE Subcontractors shall confirm receipt of payment from the Prime, electronically also, at www.dekalbblsbe.info.

3. The County's official payment terms are Net 30. Payment dates that fall on a weekend or on a holiday will be issued on the County's next business day.

L. ACCURACY OF WORK:

The Contractor shall be responsible for the accuracy of the Work and any error and/or omission made by the Contractor in any phase of the Work under this Agreement.

M. ADDITIONAL WORK:

The County shall in no way be held liable for any work performed under this section which has not first been approved in writing by the County in the manner required by applicable law and/or the terms of this Contract. The County may at any time order changes within the scope of the Work without invalidating the Contract upon seven (7) days written notice to the Contractor. The Contractor shall proceed with the performance of any changes in the Work so ordered by the County unless such change entitles the Contractor to a change in Contract Price, and/or Contract Term, in which event the Contractor shall give the County written notice thereof within fifteen (15) days after the receipt of the ordered change, and the Contractor shall not execute such changes until it receives an executed Change Order from the County. No extra cost or extension of time shall be allowed unless approved by the County and authorized by execution of a Change Order. The parties' execution of any Change Order constitutes a final settlement of all matters relating to the change in the Work which is the subject of the Change Order. The County shall not be liable for payment for any work performed under this section which has not first been approved in writing by the County in the manner required by applicable law and/or the terms of this Contract.

N. OWNERSHIP OF DOCUMENTS:

All documents, including drawings, estimates, specifications, and data are and remain the property of the County. The Contractor agrees that the County may reuse any and all plans, specifications, drawings, estimates, or any other data or documents described herein in its sole discretion without first obtaining permission of the Contractor and without any payment of any monies to the Contractor therefore. Any reuse of the documents by the County on a different site shall be at its risk and the Contractor shall have no liability where such documents are reused.

O. RIGHT TO AUDIT:

The County shall have the right to audit all books and records, including electronic records, relating or pertaining to this contract or agreement, including but not limited to all financial and performance related records, property, and equipment purchased in whole or in part with County funds and any documents or materials which support whose records, kept under the control of the Contractor, including but not limited to those kept by the Contractor's employees, agents, assigns, successors and subcontractors. The County also has the right to communicate with Contractor's employees related to the audited records.

The Contractor shall maintain such books and records, together with such supporting or underlying documents and materials, for the duration of this contract and for seven (7) years after termination or expiration, including any and all renewals thereof. The books and records, together with supporting documents and materials shall be made available, upon request to the County or its designee, during normal business hours at the Contractor's office or place of business. In the event that no such locations is available, then the books, records and supporting documents shall be made available for audit at a time and location which is convenient for the County.

P. SUCCESSORS AND ASSIGNS:

The Contractor agrees it shall not sublet, assign, transfer, pledge, convey, sell, or otherwise dispose of the whole or any part of this Contract or his right, title, or interest therein to any person, firm, or corporation without the previous written consent of the County. If the County consents to any such assignment or transfer, then the Contractor binds itself, its partners, successors and assigns to all covenants of this Contract. Nothing contained in this Contract shall create, nor be interpreted to create privity, or any other relationship whatsoever, between the County and any person, or entity or than Contractor.

Q. REVIEWS AND ACCEPTANCE:

Work performed by the Contractor shall be subject to review and acceptance in stages as required by the County. Acceptance shall not relieve the Contractor of its professional obligation to correct, at his own expense, any errors in the Work.

R. TERMINATION OF AGREEMENT:

The Contractor understands and agrees that the date of the beginning of Work, rate of progress, and time for completion of the Work are essential conditions of this Contract. Both parties may, for its own convenience and at its sole option, without cause and without prejudice to any other right or remedy of the party, elect to terminate the Contract by delivering to the other party, at the address listed in the Notices article of this Contract, a written notice of termination specifying the effective date of termination. Such notice shall be delivered to the other party at least thirty (30) days prior to the effective date of termination. If Contractor's services are terminated by the County, the termination will not affect any rights or remedies of the County then existing or which may thereafter accrue against Contractor or its surety. In case of termination of this Contract before completion of the Work, Contractor will be paid only for the portion of the Work satisfactorily performed through the effective date of termination as determined by the County. Neither party shall be entitled to recover lost profits, special, consequential or punitive damages, attorney's fees or costs from the other party to this Contract for any reason whatsoever. This Contract shall not be deemed to provide any third-party with any

remedy, claim, right of action, or other right. The parties' obligations pursuant to this Section shall survive any acceptance of Work, or termination or expiration of this Contract.

S. INDEMNIFICATION AGREEMENT:

The Contractor shall be responsible from the execution date or from the time of the beginning of the Work, whichever shall be the earlier, for all injury or damage of any kind resulting from the Work, to persons or property, including employees and property of the County. The Contractor shall exonerate, indemnify, and save harmless the County, its elected officials, officers, employees, agents and servants, hereinafter collectively referred to in this Section as "the County Indemnitees," from and against all claims or actions based upon or arising out of any damage or injury (including without limitation any injury or death to persons and any damage to property) caused by or sustained in connection with the performance of this Contract or by conditions created thereby or arising out of or any way connected with Work performed under this Contract, as well as all expenses incidental to the defense of any such claims, litigation, and actions. Furthermore, Contractor shall assume and pay for, without cost to the County Indemnitees, the defense of any and all claims, litigation, and actions suffered through any act or omission of the Contractor, or any Subcontractor, or anyone directly or indirectly employed by or under the supervision of any of them. Notwithstanding any language or provision in this Contract, Contractor shall not be required to indemnify any County Indemnitee against claims, actions, or expenses based upon or arising out of the County Indemnitee's sole negligence. As between the County Indemnitees and the Contractor as the other party, the Contractor shall assume responsibility and liability for any damage, loss, or injury, including death, of any kind or nature whatever to person or property, resulting from any kind of claim made by Contractor's employees, agents, vendors, Suppliers or Subcontractors caused by or resulting from the performance of Work under this Contract, or caused by or resulting from any error, omission, or the negligent or intentional act of the Contractor, vendors, Suppliers, or Subcontractors, or any of their officers, agents, servants, or employees. The Contractor shall defend, indemnify, and hold harmless the County Indemnitees from and against any and all claims, loss, damage, charge, or expense to which they or any of them may be put or subjected by reason of any such damage, loss, or injury. The Contractor expressly agrees to provide a full and complete defense against any claims brought or actions filed against the County Indemnitees, where such claim or action involves, in whole or in part, the subject of the indemnity contained in this Contract, whether such claims or actions are rightfully or wrongfully brought or filed. The County has the sole discretion to choose the counsel who will provide the defense. No provision of this Contract and nothing herein shall be construed as creating any individual or personal liability on the part of any elected official, officer, employee, agent or servant of the County, nor shall the Contract be construed as giving any rights or benefits hereunder to anyone other than the parties to this Contract. The parties' obligations pursuant to this Section shall survive any acceptance of Work, or termination or expiration of this Contract.

T. INSURANCE:

Insurance must meet the County's requirements and will be furnished by the successful Bidder(s) upon award.

1. Successful Bidder(s) will advise their insurance agent of the County's requirements as listed below and that they may not proceed with any work until insurance is provided that is in compliance with these requirements.
2. Contractor's insurance company or agent must mail, email, or bring an original certificate of

insurance and applicable declarations or endorsements to the DeKalb County address listed within this Insurance provision. Insurance must be from companies able to do business in Georgia and acceptable to the County as follows:

- a. Certificates must cover:
 - i. Statutory Workers Compensation
 - (1) Employer's liability insurance by accident, each accident \$1,000,000
 - (2) Employer's liability insurance by disease, policy limit \$1,000,000
 - (3) Employer's liability insurance by disease, each employee \$1,000,000
 - ii. Business Auto Liability Insurance with a minimum \$500,000 Combined Single Limit/Each Occurrence (Including operation of non-owned, owned, and hired automobiles).
 - iii. Commercial General Liability Insurance
 - (1) Each Occurrence - \$1,000,000
 - (2) Fire Damage - \$250,000
 - (3) Medical Expense - \$10,000
 - (4) Personal & Advertising Injury - \$1,000,000
 - (5) General Aggregate - \$2,000,000
 - (6) Products & Completed Operations - \$1,500,000
 - (7) Contractual Liability where applicable
- b. DeKalb County, GA shall be named as Additional Insured under any General Liability, Business Auto and Umbrella Policies. Coverage shall apply as Primary and non-contributory with Waiver of Subrogation in favor of DeKalb County, Georgia. Such additional insured coverage shall be endorsed to Contractor's policy by attachment of ISO Additional Insured Endorsement forms CG 20 10 10 01 (ongoing operations) and CG 20 37 10 01 (products- completed operations), or form(s) providing equivalent coverage.
- c. This insurance for the County as the additional insured shall be as broad as the coverage provided for the named-insured Contractor. It shall apply as primary insurance before any other insurance or self-insurance, including any deductible, non-contributory, and waiver of subrogation provided to the County as the additional insured.
- d. Contractor agrees to waive all rights of subrogation and other rights of recovery against the County and its elected officials, officers, employees or agents, and shall cause each Subcontractor to waive all rights of subrogation for all coverages.
- e. Certificates shall state that the policy or policies shall not expire, be cancelled or altered without at least sixty (60) days prior written notice to the County.
- f. Contractor understands and agrees that the purchase of insurance in no way

limits the liability of the Contractor.

- g. The insurance carrier must have a minimum A.M. Best rating of not less than “A” (Excellent) with a Financial Size Category of VII or better.
- h. Certificates to contain policy number, policy limits and policy expiration date of all policies issued in accordance with this contract.
- i. Certificates to contain the location and operations to which the insurance applies.
- j. Certificates to contain successful contractor’s protective coverage for any subcontractor’s operations. If this coverage is included in General Liability, please indicate on the Certificate of Insurance.
- k. Certificates to contain successful contractor’s contractual insurance coverage. If this coverage is included in the General Liability, please indicate this on the Certificate of Insurance.
- l. Certificates shall be issued and delivered to the County and must identify the “Certificate Holder” as follows:

DeKalb County, Georgia
Director of Purchasing and Contracting
Malooof Administration Building
1300 Commerce Drive, 2nd Floor
Decatur, Georgia 30030

- m. The successful contractor shall be wholly responsible for securing certificates of insurance coverage as set forth above from all subcontractors who are engaged in this work.

U. GEORGIA LAWS GOVERN:

The laws of the State of Georgia shall govern the construction of this Contract without regard for conflicts of laws. Should any provision of this Contract require judicial interpretation, it is agreed that the court interpreting or construing the same shall not apply a presumption that the terms hereof shall be more strictly construed against one party, by reason of the rule of construction, that a document is to be construed more strictly against the party who itself or through its agent prepared same; it being agreed that the agents of all parties have participated in the preparation hereof, and all parties have had an adequate opportunity to consult with legal counsel. In interpreting this Contract in its entirety, the printed provisions of this Contract, and any additions written or typed hereon, shall be given equal weight, and there shall be no inference by operation of law or otherwise; that any provision of this Contract shall be construed against either party hereto.

V. VENUE:

This Agreement shall be deemed to have been made and performed in DeKalb County, Georgia. For the purposes of venue, all suits or causes of action arising out of this Agreement shall be brought in the courts of DeKalb County, Georgia.

W. COUNTY REPRESENTATIVE:

The County may designate a representative through whom the Contractor will contact the County. In the event of such designation, said representative shall be consulted and his written recommendation obtained before any request for extra work is presented to the County. Payments to the Contractor shall be made only upon itemized bill submitted to and approved by said representative.

X. CONTRACTOR'S STATUS:

The Contractor will supervise and direct the Work, including the Work of all Subcontractors. Only persons skilled in the type of work which they are to perform shall be employed. The Contractor shall, at all times, maintain discipline and good order among his employees, and shall not employ any unfit person or persons or anyone unskilled in the work assigned him. The relationship between the County and the Contractor shall be that of owner and independent contractor. Other than the consideration set forth herein, the Contractor, its officers, agents, servants, employees, and any Subcontractors shall not be entitled to any County employee benefits including, but not limited to social security, insurance, paid annual leave, sick leave, worker's compensation, free parking or retirement benefits. All services provided by Contractor shall be by employees of Contractor or its Subcontractors and subject to supervision by Contractor. No officer or employee of Contractor or any Subcontractor shall be deemed an officer or employee of the County. Personnel policies, tax responsibilities, social security payments, health insurance, employee benefits and other administrative policies, procedures or requirements applicable to the Work or services rendered under this Contract shall be those of the Contractor, not the County.

Y. SOLE AGREEMENT:

This Contract constitutes the sole contract between the County and the Contractor. The terms, conditions, and requirements of this Contract may not be modified. No verbal agreement or conversation with any officer, agent, or employee of the County, either before or after the award of the Contract, shall affect or modify any of the terms or obligations herein contained. No representations, oral or written, shall be binding on the parties unless expressly incorporated herein.

Z. SEVERABILITY:

If any provision of this Contract or the application thereof to any person or circumstance shall to any extent be held invalid, then the remainder of this Contract or the application of such provision to persons or circumstances, other than those as to which it is held invalid, shall not be affected thereby, and each provision of this Contract shall be valid and enforced to the fullest extent permitted by law.

AA. NOTICES:

Any notice or consent required to be given by or on behalf of any party hereto to any other party hereto shall be in writing and shall be sent to the Director of the Department of Purchasing and Contracting or to the Contractor or his authorized representative on the work site by (a) registered or certified United States mail, return receipt requested, postage prepaid, (b) personal delivery, or (c) overnight courier service. All notices sent to the addresses listed below shall be binding unless said address is changed in writing no less than fourteen days before such notice is sent. Future changes in address shall be effective upon written notice being given by the Contractor

to the Director of the Department of Purchasing and Contracting or by the County to the Contractor's authorized representative via certified first class U.S. mail, return receipt requested. Such notices will be addressed as follows:

If to the County:

Chief Procurement Officer
Department of Purchasing and Contracting
Malooof Administration Building
1300 Commerce Drive, 2nd Floor
Decatur, Georgia 30030

If to the Contractor: Notices shall be sent to the contact information that is listed in the Bidder's Response to the ITB.

BB. GEORGIA OPEN RECORDS ACT:

Without regard to any designation made by the person or entity making a submission, DeKalb County considers all information submitted in response to this invitation or request to be a public record that will be disclosed upon request pursuant to the Georgia Open Records Act, O.C.G.A. §50-18-70 et seq., without consulting or contacting the Responder person or entity making the submission, unless a court order is presented with the submission. Bidders or Responders may wish to consult an attorney or obtain legal advice prior to making a submission.

CC. DEKALB COUNTY, GEORGIA'S TITLE VI POLICY STATEMENT

DeKalb County, Georgia is committed to compliance with Title VI of the Civil Rights Act of 1964 and all related regulations and directives. DeKalb County assures that no person shall on the grounds of race, color, sex, or national origin, as provided by Title VI of the Civil Rights Act of 1964, the Federal-Aid Highway Transportation Act of 1973, and the Civil Rights Restoration Act of 1987 be excluded from participation in, be denied the benefits of, or be otherwise subjected to discrimination under any program or activity. DeKalb County further assures that no person shall on the grounds of age, low income, disability, sexual orientation or gender identity be excluded from participation in, be denied the benefits of, or be otherwise subjected to discrimination under any program or activity.

DeKalb County assures every effort will be made to ensure nondiscrimination in all of its programs and activities, whether those programs and activities are federally funded or not. In addition, DeKalb County will take reasonable steps to provide meaningful access to services for persons with Limited English Proficiency (LEP).

DD. COOPERATIVE PROCUREMENT

The County through the Department of Purchasing & Contracting may permit piggybacks to this contract from other city, county, local authority, agency, or board of education if the vendor will extend the same prices, terms, and conditions to the city. Piggybacking shall only be available where competition was used to secure the contract and only for a period of 12-months following entry, renewal or extension of the contract. This provision shall not apply to any contract where otherwise prohibited or mandated by state law.

MINIMUM SPECIFICATIONS

I. QUALIFICATION REQUIREMENTS:

General Contractor/Bidder – The bidder shall be engaged in the construction of Basketball Courts as a primary business enterprise and shall demonstrate the construction of at least six complete basketball court projects within the last 3 years, which includes certifications for this work. Upon request and for evaluation of previous installations, the surfacing contractor, if different from the prime, shall furnish the name, owner and contact person for every tennis court surface that they have installed in the three previous years.

Financial statements for the previous three (3) years must be made available upon request.

The contractor shall demonstrate proven capability, specifically, in the installations of the scope and type proposed for this project and demonstrate that they have been in business, under the present name, a minimum of five (5) years prior to the date of this bid as evidenced by the Contractor's Reference and Release Form.

II. SCHEDULE OF COMPLETION

Work must begin within ten (10) days from the date the Contractor acknowledges receipt of the Notice to Proceed. Contractor shall fully complete the Work within 180 days from and including the acknowledgement date. For failure to complete the Work within this period, the Contractor shall pay the County liquidated damages in the amount of four hundred fifty dollars and 00/100 Dollars (\$450.00) for each day in excess of the Contract Time unless an extension of the Contract Time has been obtained by Change Order, as defined in the Contract, prior to the expiration of the Contract Term as defined in the Contract.

III. WORK HOURS

DeKalb County Parks and Recreation facilities are open from dawn to dusk. Work may be completed within this timeframe, Monday-Friday. Weekend work is not permissible without express written consent of the contract manager for RPCA.

IV. SCOPE OF WORK:

A. Crack Repair Tennis Courts (Refer to Line items 1-12) – Included within this ITB, there are three parks which require hard court crack repair. The parks are:

1. Glen Emerald - 1479 Bouldercrest Road Atlanta, GA 30316– 2 courts
2. DeKalb Tennis Center- 1346 McConnell Drive Decatur, GA 30033 – 17 courts
3. Bouldercrest Park- 4184 Bouldercrest Park Road Ellenwood, GA 30294 – 2 courts

The bidder shall base the cost of the repairs on the Riteway Crack Repair system. The specifications can be found in Attachment A. The length of cracks and low lying areas are estimated quantities and need to be field verified. If, at the time of the award, the estimated quantities are over by 10% of the estimated value, Line items 20 can be utilized. Failure to provide an estimate for any line item will deem the bidder non-responsive.

B. Full Court Replacement Tennis Courts (Refer to Line Items 1-9, 13-19)– Included within this ITB, there are four parks which require full court replacement. They are as follows:

1. WD Thomson - *1760 Mason Mill Road Atlanta, GA 30329* – 2 courts
2. Midway Park - *3181 Midway Road Decatur, GA 30032* – 2 courts
3. Emory Grove Park - *1937 Westminster Way Atlanta, GA 30307* – 2 courts
4. Shoal Creek II- *3643 Glenwood Road Decatur, GA 30032* – 4 courts

The bidder shall base the cost of the court replacement on the cross section shown in Detail “A”, Attachment E. The work consists of full demolition of the existing courts a minimum of 6 1/2” inches. All removed material must be hauled off site. Verification of a minimum of a 12” subgrade will be performed and if the subgrade is less than 12” thick, then additional subgrade must be added to reach 12”. The existing grade of the courts shall be maintained to achieve a slope for runoff. Minor adjustments may need to be made to maintain a positive slope.

The installation of new courts shall consist of a 4” graded aggregate course, 1 1/2” of leveling course, type “B” bituminous concrete, a tack coat layer, and 1” surface course Type “F” bituminous concrete. Final coating should be applied as an asphaltic patching re-surfacer and 2 coats of an acrylic color surface. Failure to provide an estimate for any line item will deem the bidder non-responsive.

For each full tennis court replacement, the perimeter fence and posts shall also be replaced. The fence replacement shall consist of 8-foot-tall black coated vinyl 9-gauge core, 1 3/4” mesh fabric with top and bottom rails. Line posts shall be two 1/2 inch (2 1/2”) O.D., Schedule 40 with 3000 psi concrete foundations, 9 inches wide and 36 inches deep, spaced every 10 feet O.C. The post holes shall be in proper alignment so that there is a minimum of 3 inches of concrete on all sides of the posts. End posts shall be 3-inch O.D. (3”), Schedule 40. The post holes shall be in proper alignment so that there is a minimum of 3 inches of concrete on all sides of the posts. Top rail and bottom rail shall be one and five eighth inches O.D. (1-5/8”), Schedule 40.

There shall be one pedestrian gate, 36” wide, placed at each tennis court for access. There shall also be two openings at the base of each fence located at each court to blow leaves and debris off the court. The gate and opening locations will be determined during construction.

It is the responsibility of the bidder to visit each site on their own and validating such by completing and returning the Site Acknowledgement Form as noted on the Required Documents Checklist, Attachment K.

ATTACHMENT A



RiteWay Crack Repair Installation Guidelines

1. Crack must be free of dirt & debris.
2. Crack must be filled from bottom to top with court patch binder or cement and let dry.
3. Filled Crack must be scraped or buffed flush with court and cleaned, broomed and blown.
4. Area to be repaired must be DRY and at 60°F or higher.
5. First layer is to be centered over Crack by removing a few inches of the release liner exposing the soft sealant apply to Crack when centered, pull release liner to move along Crack. If Crack turns cut tape and butt up another piece and continue. Make sure there are no bubbles. If a bubble is found cut with razor knife and press out bubble. Roll with tape machine pressing firmly.
6. Apply Liquid Acrylic(NO Sand) and Latex binding formula(NO Sand) (50/50) over tape with paint roller approximately 24" wide. Apply 20" stress mat centered over first layer making sure there are no wrinkles, etc. Using roller saturate stress mat with liquid acrylic, making sure there are no bubbles and roll smooth.
7. Apply bonding edge ½ on fabric ½ on court and roll on Liquid Acrylic making sure there are no wrinkles or bubbles and let dry.
8. When dry use 9" roller to apply binding formula over the RiteWay Tape area of the repair, approximately 12" wide, let dry and repeat once more
9. When totally dry squeegee resurfacer with sand lengthwise over crack this will fill voids where layers overlap and hide the repair. Minimum of two coats are recommended. Repair is complete.

Box Contents: (6) 50' rolls of RiteWay Tape (Grey)
(1) 309' roll of RW Stress Mat (White)
(4) 175' rolls of RW Bonding Edge (Yellow)

TOLL FREE
877-5-RITEWAY
(877-574-8392)

U. S. Patent No. 7,597,50

RiteWay

Guaranteed Tennis Court Crack Repair

Cut Sheet

1. #4 = Base
2. #8 & 10 = Filled Crack
3. #12 & 14 = RiteWay Seam Tape 6"
4. #18, 20 & 22 = RiteWay Stress Matt 20"
5. #24A & B = RiteWay Bonding Edge 9"

RiteWay Seam Tape utilizes advanced Exclusive Technology, a 100% solids formulation of synthetic resins, thermoplastics and non-curing rubber (non-butyl) with a built-in primer, bonded to a woven polyester backing for maximum comfortability.

Designed NOT to harden under even the most rigorous conditions. Sag temperature >200° F. Adhesive is protected (while in a roll) by a tough, easily removed siliconized release liner, which prevents contaminations prior to its use. All materials are prefabricated to provide uniform thickness.

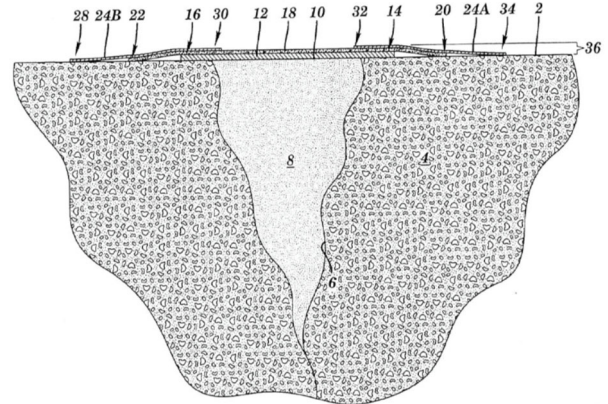
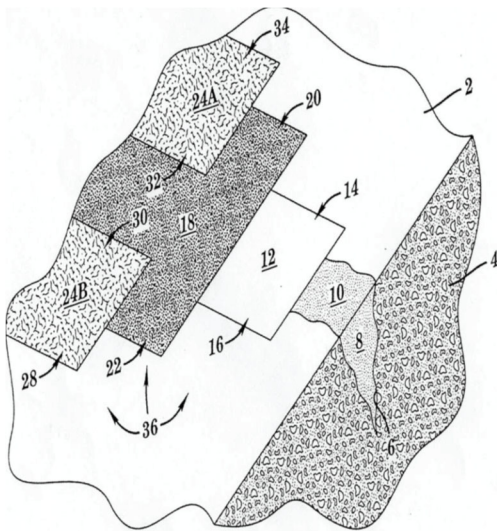

Technical Data

Total Thickness.....	30 Mils (1mm)
Adhesion	19 lbs/in width
Low-Temp Flexibility.....	Excellent
Temperature.....	-70°F - <200° F
Pliability.....	No membrane cracks
Water Vapor Test (ASTME 96B).....	.005 grms/100" sq./24hours/100°
Permanence.....	.001 perms maximum
Elongation.....	>500%
Application Temperature.....	>150°F to 20°F

ATTACHMENT B

NOTE:
 THE NET SHOULD BE INSTALLED
 WITH A RECOMMENDED TENSION OF
 450 LBS. FOR RECREATIONAL COURTS
 & 550 LBS. FOR PROFESSIONAL COURTS

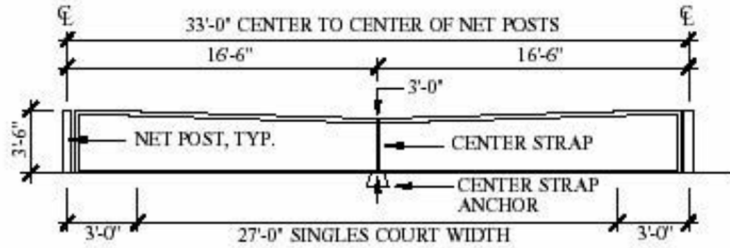

SINGLES NET

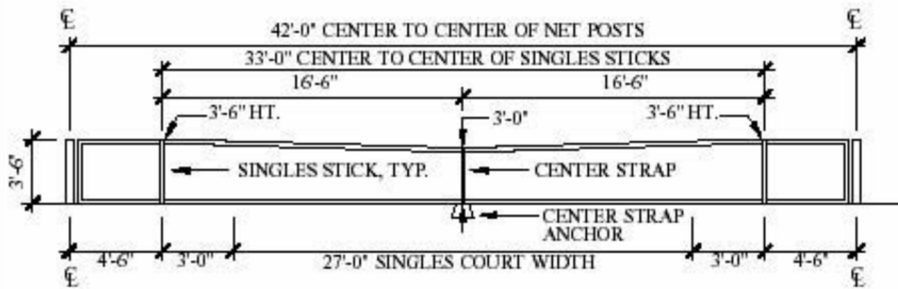

DOUBLES NET W/SINGLES STICKS

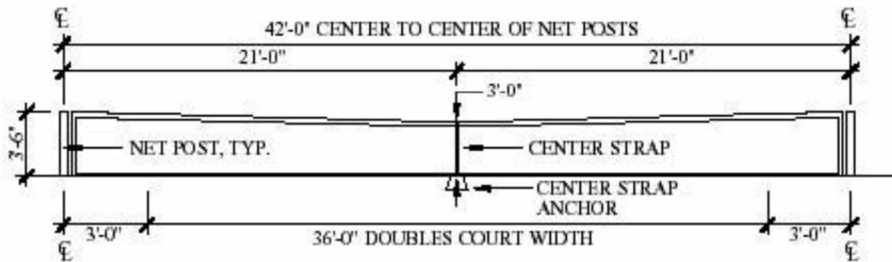

DOUBLES NET

TYPICAL TENNIS NET ELEVATIONS

NOT TO SCALE

31NETELEV.AVL.03B

ATTACHMENT C

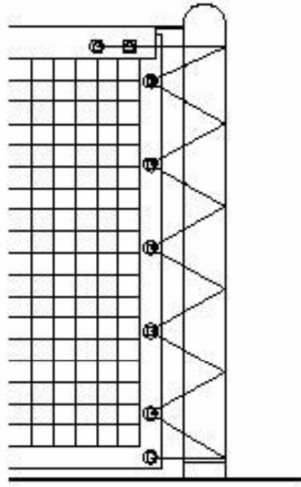

TYPICAL ELEVATION OF A PROPERLY LACED NET

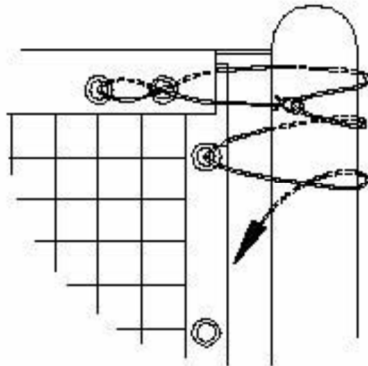

NET LACING DIAGRAM

TYPICAL NET LACING DIAGRAM

NOT TO SCALE

48NETELV2.AVL.03

ATTACHMENT D

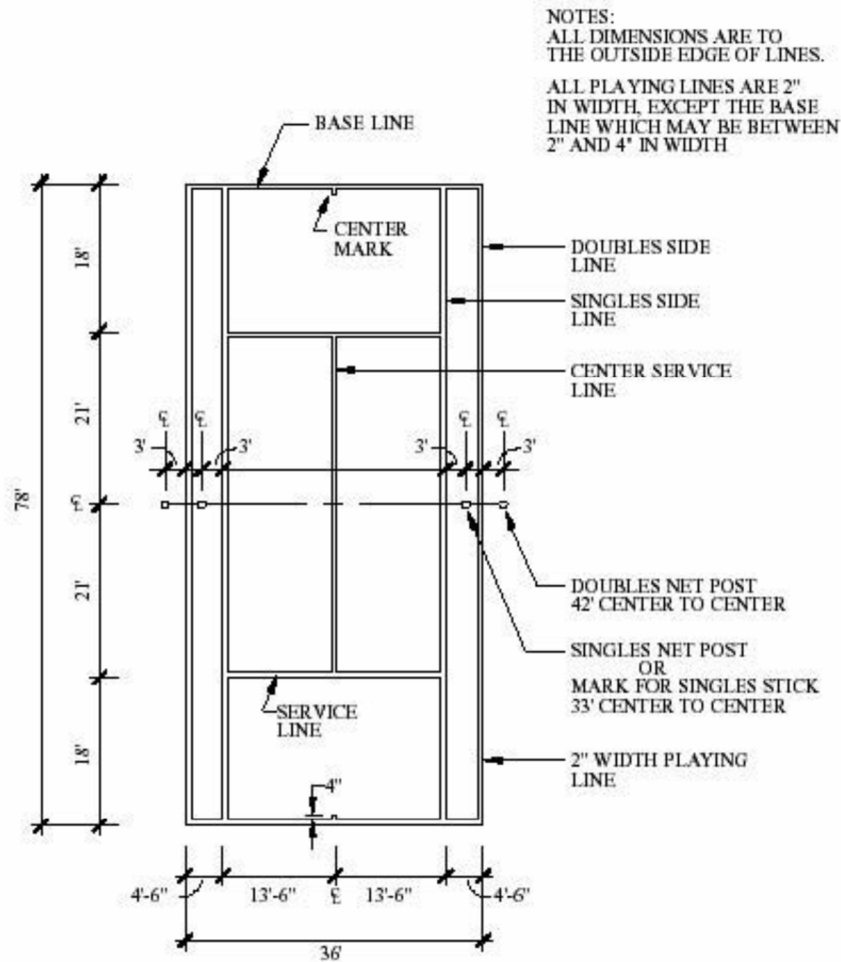

NOTES:
 ALL DIMENSIONS ARE TO THE OUTSIDE EDGE OF LINES.
 ALL PLAYING LINES ARE 2" IN WIDTH, EXCEPT THE BASE LINE WHICH MAY BE BETWEEN 2" AND 4" IN WIDTH

TENNIS COURT PLAYING LINE LAYOUT PLAN

NOT TO SCALE

2PLINES.AVL.03

ATTACHMENT E

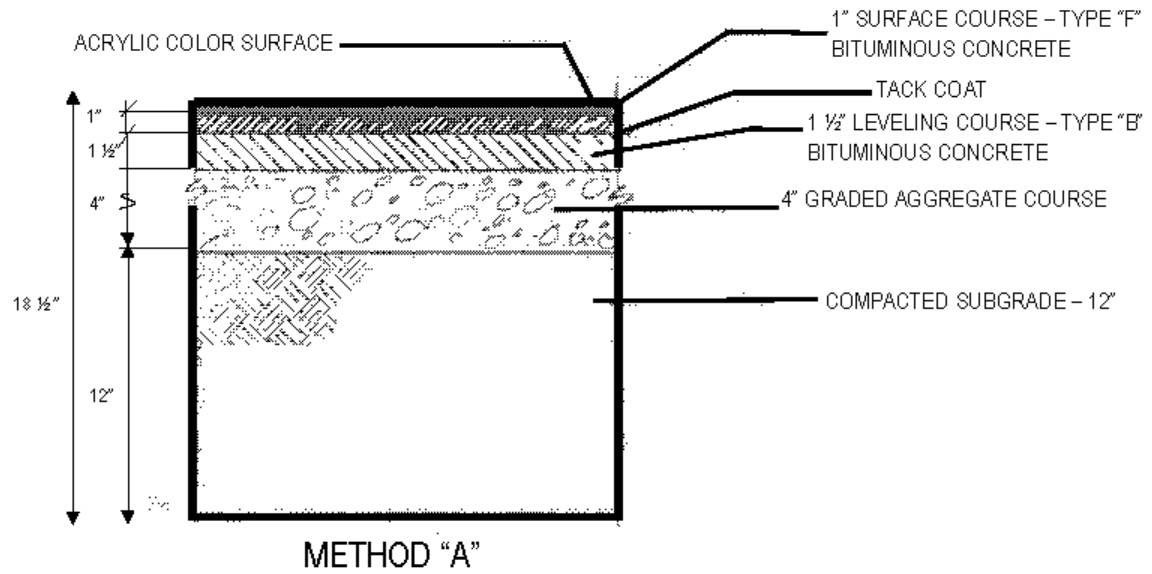

COURT CROSS SECTION

N.T.S

ATTACHMENT F

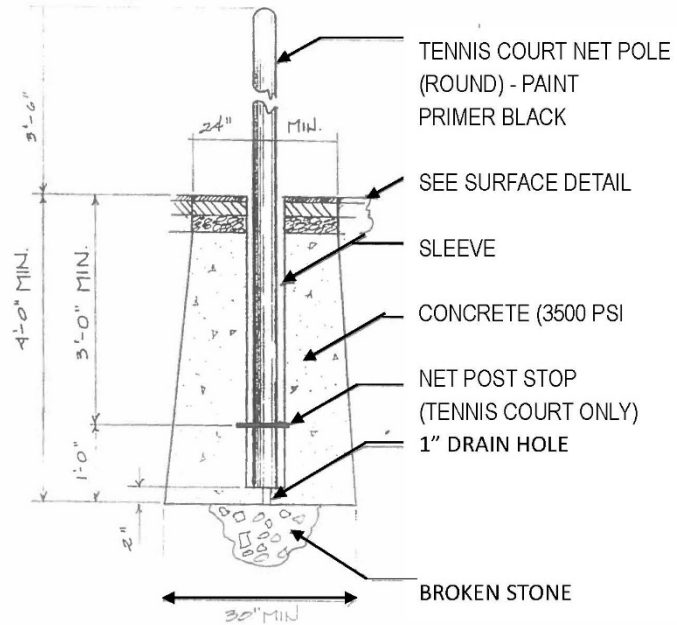

POST DETAIL

ATTACHMENT G

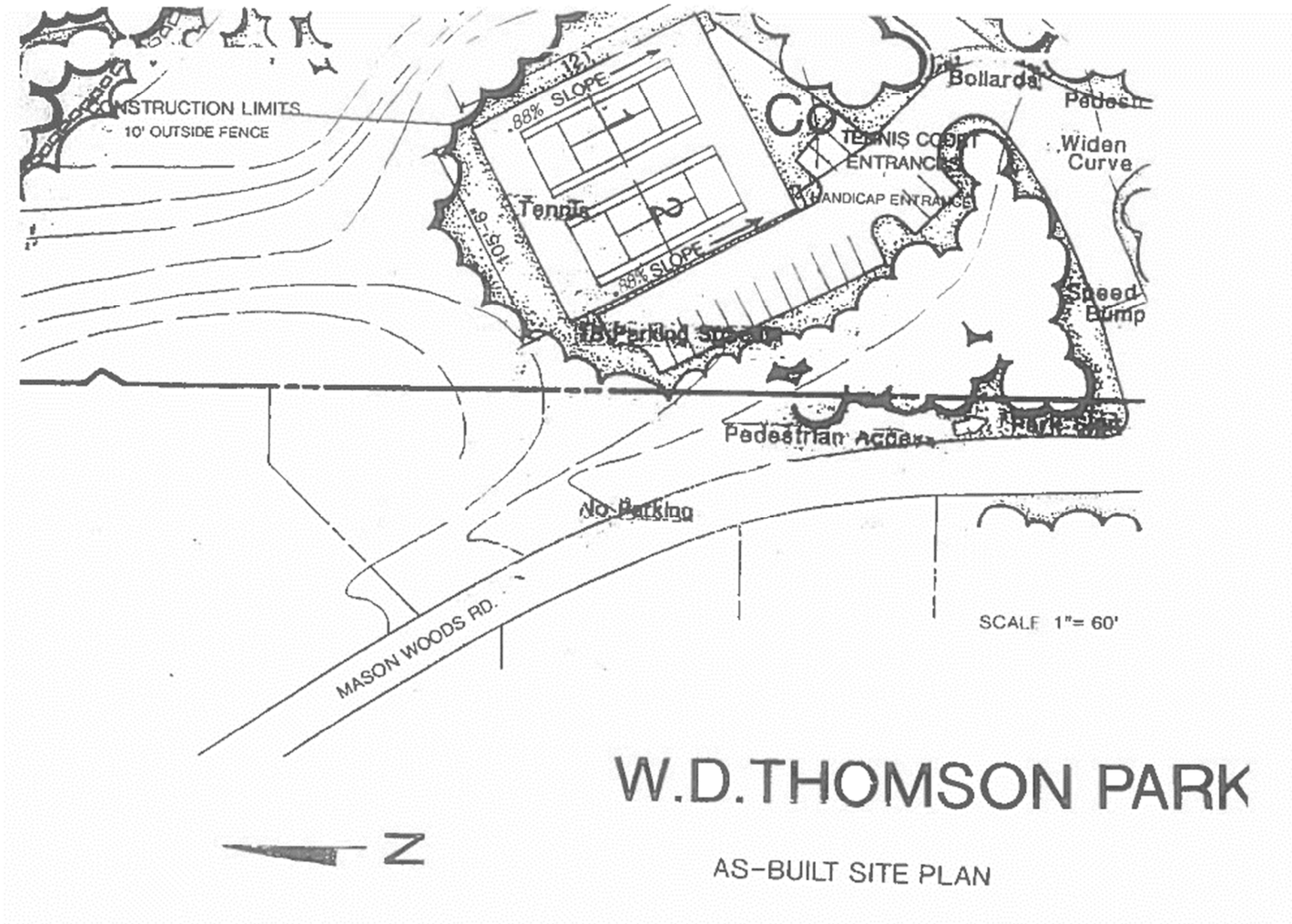

ATTACHMENT H

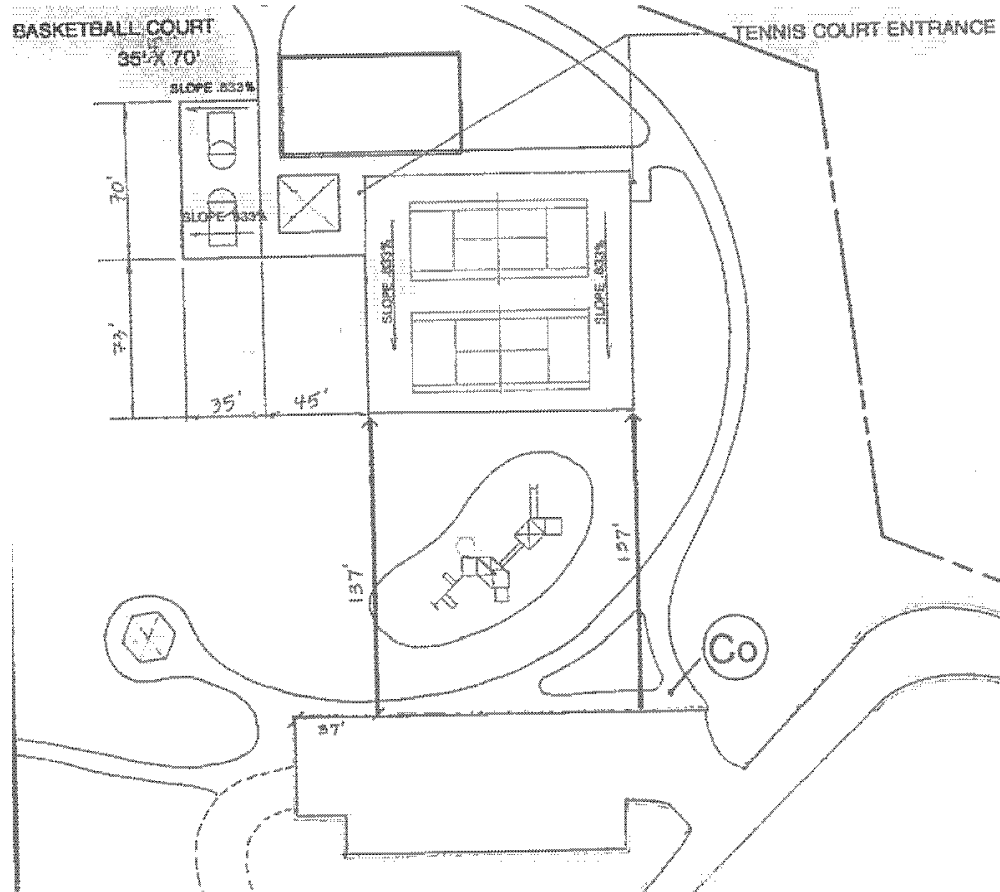

BOULDERCREST PARK

ATTACHMENT I

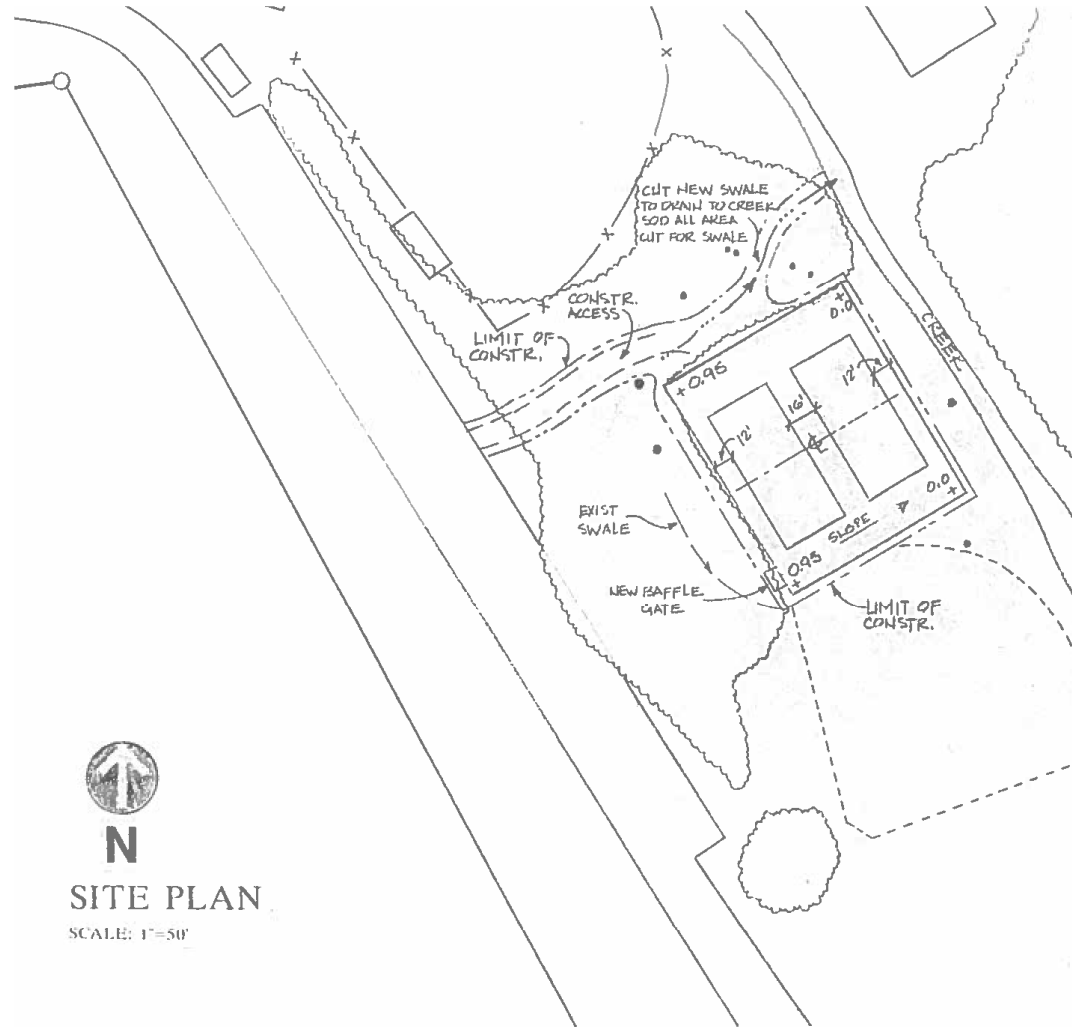

N
SITE PLAN
SCALE: 1"=50'

MIDWAY PARK

ATTACHMENT J

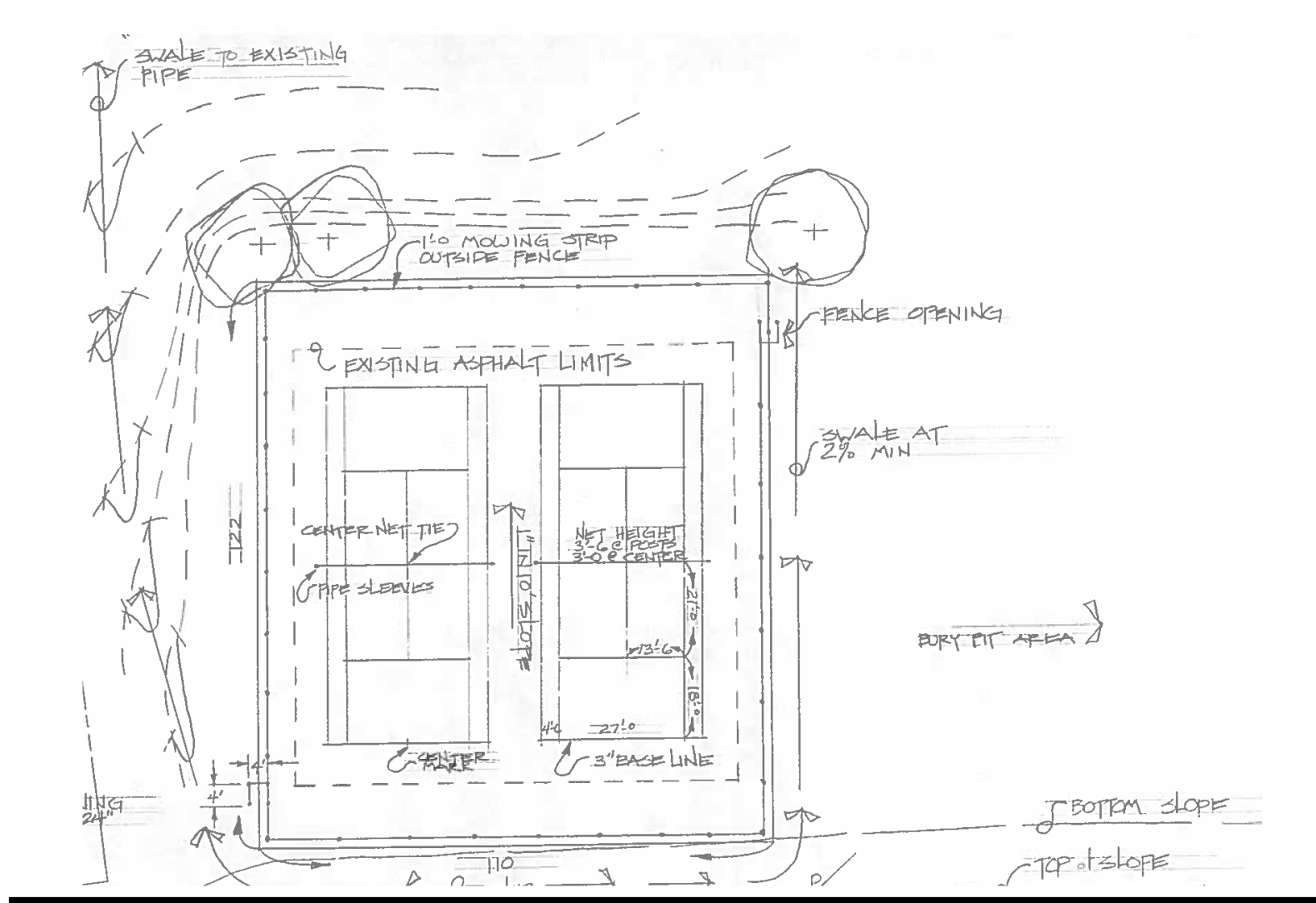

EMORY GROVE PARK



Emory Grove Park - 1937 Westminster Way



Date Printed: 12/11/2019



DeKalb County GIS Disclaimer

The maps and data contained on DeKalb County's Geographic Information System (GIS) are subject to constant change. While DeKalb County strives to provide accurate and up-to-date information, the information is provided "as is" without warranty, representation or guarantee of any kind as to the content, sequence, accuracy, timeliness or completeness of any of the database information provided herein. DeKalb County explicitly disclaims all representations and warranties, including, without limitation, the implied warranties of merchantability and fitness for a particular purpose. In no event shall DeKalb County be liable for any special, indirect, or consequential damages whatsoever resulting from loss of use, data, or profits, whether in an action of contract, negligence, or other actions, arising out of or in connection with the use of the maps and/or data herein provided. The maps and data are for illustration purposes only and should not be relied upon for any reason. The maps and data are not suitable for site-specific decision-making nor should it be construed or used as a legal description. The areas depicted by maps and data are approximate, and are not necessarily accurate to surveying or engineering standards.



Tennis Court
IS 179 04167



Midway Park - 3181 Midway Road



Date Printed: 12/11/2019



DeKalb County GIS Disclaimer
The maps and data contained on DeKalb County's Geographic Information System (GIS) are subject to constant change. While DeKalb County strives to provide accurate and up-to-date information, the information is provided "as is" without warranty, representation or guarantee of any kind as to the content, sequence, accuracy, timeliness or completeness of any of the database information provided herein. DeKalb County explicitly disclaims all representations and warranties, including, without limitation, the implied warranties of merchantability and fitness for a particular purpose. In no event shall DeKalb County be liable for any special, indirect, or consequential damages whatsoever resulting from loss of use, data, or profits, whether in an action of contract, negligence, or other actions, arising out of or in connection with the use of the maps and/or data herein provided. The maps and data are for illustration purposes only and should not be relied upon for any reason. The maps and data are not suitable for site-specific decision-making nor should it be construed or used as a legal description. The areas depicted by maps and data are approximate, and are not necessarily accurate to surveying or engineering standards.



WD Thomson - 1760 Mason Mill Road



Date Printed: 12/11/2019



DeKalb County GIS Disclaimer

The maps and data, contained on DeKalb County's Geographic Information System (GIS) are subject to constant change. While DeKalb County strives to provide accurate and up-to-date information, the information is provided "as is" without warranty, representation or guarantee of any kind as to the content, sequence, accuracy, timeliness or completeness of any of the database information provided herein. DeKalb County explicitly disclaims all representations and warranties, including, without limitation, the implied warranties of merchantability and fitness for a particular purpose. In no event shall DeKalb County be liable for any special, indirect, or consequential damages whatsoever resulting from loss of use, data, or profits, whether in an action of contract, negligence, or other actions, arising out of or in connection with the use of the maps and/or data herein provided. The maps and data are for illustration purposes only and should not be relied upon for any reason. The maps and data are not suitable for site-specific decision-making nor should it be construed or used as a legal description. The areas depicted by maps and data are approximate, and are not necessarily accurate to surveying or engineering standards.



Bouldercrest Park- 4184 Bouldercrest Park Road



Date Printed: 12/11/2019



DeKalb County GIS Disclaimer
The maps and data, contained on DeKalb County's Geographic Information System (GIS) are subject to constant change. While DeKalb County strives to provide accurate and up-to-date information, the information is provided "as is" without warranty, representation or guarantee of any kind as to the content, sequence, accuracy, timeliness or completeness of any of the database information provided herein. DeKalb County explicitly disclaims all representations and warranties, including, without limitation, the implied warranties of merchantability and fitness for a particular purpose. In no event shall DeKalb County be liable for any special, indirect, or consequential damages whatsoever resulting from loss of use, data, or profits, whether in an action of contract, negligence, or other actions, arising out of or in connection with the use of the maps and/or data herein provided. The maps and data are for illustration purposes only and should not be relied upon for any reason. The maps and data are not suitable for site-specific decision-making nor should it be construed or used as a legal description. The areas depicted by maps and data are approximate, and are not necessarily accurate to surveying or engineering standards.

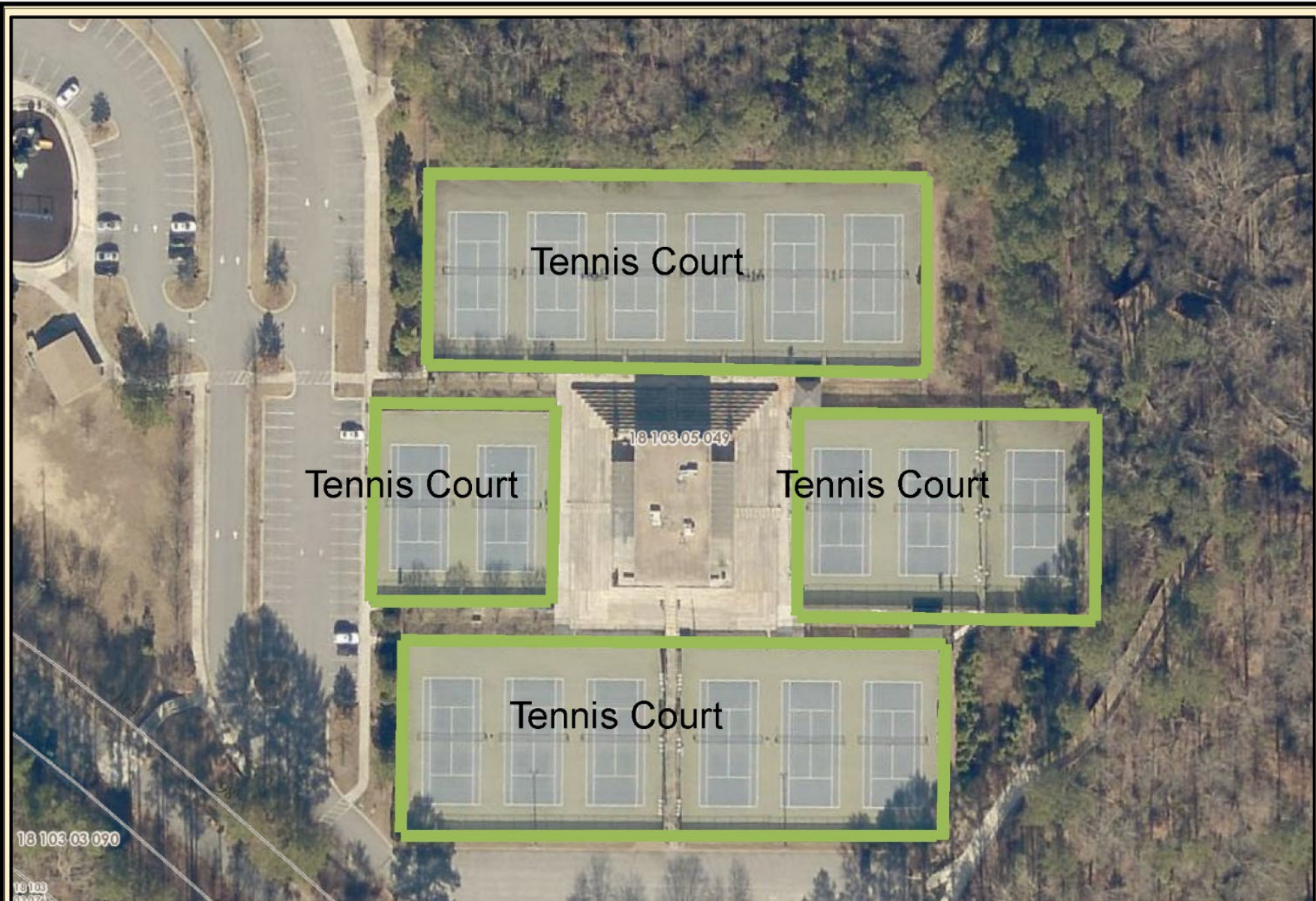

Tennis Center- 1346 McConnell Drive



Date Printed: 12/11/2019



DeKalb County GIS Disclaimer
The maps and data, contained on DeKalb County's Geographic Information System (GIS) are subject to constant change. While DeKalb County strives to provide accurate and up-to-date information, the information is provided "as is" without warranty, representation or guarantee of any kind as to the content, sequence, accuracy, timeliness or completeness of any of the database information provided herein. DeKalb County explicitly disclaims all representations and warranties, including, without limitation, the implied warranties of merchantability and fitness for a particular purpose. In no event shall DeKalb County be liable for any special, indirect, or consequential damages whatsoever resulting from loss of use, data, or profits, whether in an action of contract, negligence, or other actions, arising out of or in connection with the use of the maps and/or data herein provided. The maps and data are for illustration purposes only and should not be relied upon for any reason. The maps and data are not suitable for site-specific decision-making nor should it be construed or used as a legal description. The areas depicted by maps and data are approximate, and are not necessarily accurate to surveying or engineering standards.



Tennis Court

15 114 03 001

1479

Basketball Court

Basketball Court

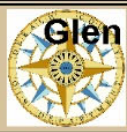

Glen Emerald - 1479 Bouldercrest Road



Date Printed: 12/11/2019



DeKalb County GIS Disclaimer
The maps and data contained on DeKalb County's Geographic Information System (GIS) are subject to constant change. While DeKalb County strives to provide accurate and up-to-date information, the information is provided "as is" without warranty, representation or guarantee of any kind as to the content, sequence, accuracy, timeliness or completeness of any of the database information provided herein. DeKalb County explicitly disclaims all representations and warranties, including, without limitation, the implied warranties of merchantability and fitness for a particular purpose. In no event shall DeKalb County be liable for any special, indirect, or consequential damages whatsoever resulting from loss of use, data, or profits, whether in an action of contract, negligence, or other actions, arising out of or in connection with the use of the maps and/or data herein provided. The maps and data are for illustration purposes only and should not be relied upon for any reason. The maps and data are not suitable for site-specific decision-making nor should it be construed or used as a legal description. The areas depicted by maps and data are approximate, and are not necessarily accurate to surveying or engineering standards.



Shoal Creek II- 3643 Glenwood Road



Date Printed: 12/11/2019



DeKalb County GIS Disclaimer

The maps and data contained on DeKalb County's Geographic Information System (GIS) are subject to constant change. While DeKalb County strives to provide accurate and up-to-date information, the information is provided "as is" without warranty, representation or guarantee of any kind as to the content, sequence, accuracy, timeliness or completeness of any of the database information provided herein. DeKalb County explicitly disclaims all representations and warranties, including, without limitation, the implied warranties of merchantability and fitness for a particular purpose. In no event shall DeKalb County be liable for any special, indirect, or consequential damages whatsoever resulting from loss of use, data, or profits, whether in an action of contract, negligence, or other actions, arising out of or in connection with the use of the maps and/or data herein provided. The maps and data are for illustration purposes only and should not be relied upon for any reason. The maps and data are not suitable for site-specific decision-making nor should it be construed or used as a legal description. The areas depicted by maps and data are approximate, and are not necessarily accurate to surveying or engineering standards.

*** PRICE SCHEDULE MUST BE SUBMITTED IN A SEPARATE SEALED ENVELOPE OR BIDDER WILL BE DEEMED NON-RESPONSIVE AND WILL NOT BE CONSIDERED FOR AWARD. INCLUDING THE PRICE SCHEDULE IN ANY AREA OUTSIDE OF THE SEPARATE SEALED ENVELOPE WILL RESULT IN THE BID BEING DEEMED NON-RESPONSIVE.***

BID PRICE SCHEDULE

ITEM NO.	ITEM DESCRIPTION	EST QTY	UNIT	PRICE PER UNIT	TOTAL PRICE
CRACK REPAIR AND FULL COURT REPLACEMENT (LINE ITEMS 1-9)					
1	REMOVE EXISTING NETS AND POSTS				
	a. Shoal Creek II – 4 courts	1	LUMPSUM	\$	\$
	b. Glen Emerald Park – 4 courts	1	LUMPSUM	\$	\$
	c. DeKalb Tennis Center – 17 courts	1	LUMPSUM	\$	\$
	d. Bouldercrest Park – 3 courts	1	LUMPSUM	\$	\$
	f. WD Thomson – 2 courts	1	LUMPSUM	\$	\$
	g. Midway Park – 2 courts	1	LUMPSUM	\$	\$
	h. Emory Grove Park – 2 courts	1	LUMPSUM	\$	\$
2	REMOVE ANY TRASH RECEPTACLES, SCOREBOARDS, BENCHES, ETC. FROM COURT AREA, KEEP FOR REUSE				
	a. Shoal Creek II – 4 courts	1	LUMPSUM	\$	\$
	b. Glen Emerald Park – 2 courts	1	LUMPSUM	\$	\$
	c. DeKalb Tennis Center – 17 courts	1	LUMPSUM	\$	\$
	d. Bouldercrest Park – 2 courts	1	LUMPSUM	\$	\$
	f. WD Thomson – 2 courts	1	LUMPSUM	\$	\$
	g. Midway Park – 2 courts	1	LUMPSUM	\$	\$
	h. Emory Grove Park – 2 courts	1	LUMPSUM	\$	\$
3	CLEAN ALL DEBRIS AND LOOSE MATERIAL FROM COURTS AND CRACKS				
	a. Shoal Creek II – 4 courts	1	LUMPSUM	\$	\$
	b. Glen Emerald Park – 2 courts	1	LUMPSUM	\$	\$
	c. DeKalb Tennis Center – 17 courts	1	LUMPSUM	\$	\$
	d. Bouldercrest Park – 2 courts	1	LUMPSUM	\$	\$
	f. WD Thomson – 2 courts	1	LUMPSUM	\$	\$
	g. Midway Park – 2 courts	1	LUMPSUM	\$	\$
	h. Emory Grove Park – 2 courts	1	LUMPSUM	\$	\$

4	APPLY ONE APPLICATION OF ACRYLIC RESURFACER OVER PLAYING SURFACE MIXED WITH SILICA SAND				
	a. Shoal Creek II – 4 courts	1	LUMPSUM	\$	\$
	b. Glen Emerald Park – 4 courts	1	LUMPSUM	\$	\$
	c. DeKalb Tennis Center – 17 courts	1	LUMPSUM	\$	\$
	d. Bouldercrest Park – 3 courts	1	LUMPSUM	\$	\$
	f. WD Thomson – 2 courts	1	LUMPSUM	\$	\$
	g. Midway Park – 2 courts	1	LUMPSUM	\$	\$
	h. Emory Grove Park – 2 courts	1	LUMPSUM	\$	\$
5	APPLY TWO COATS OF FORTIFIED ACRYLIC COLOR COAT/SPORT COAT OVER ENTIRE PLAYING SURFACE MIXED WITH SILICA SAND				
	a. Shoal Creek II – 4 courts	1	LUMPSUM	\$	\$
	b. Glen Emerald Park – 4 courts	1	LUMPSUM	\$	\$
	c. DeKalb Tennis Center – 17 courts	1	LUMPSUM	\$	\$
	d. Bouldercrest Park – 3 courts	1	LUMPSUM	\$	\$
	f. WD Thomson – 2 courts	1	LUMPSUM	\$	\$
	g. Midway Park – 2 courts	1	LUMPSUM	\$	\$
	h. Emory Grove Park – 2 courts	1	LUMPSUM	\$	\$
6	STRIPE COURT LINES WITH ONE COAT OF PRIMER AND TWO COATS OF TEXTURIZED WHITE LINE PAINT (see attachment D)				
	a. Shoal Creek II – 4 courts	1	LUMPSUM	\$	\$
	b. Glen Emerald Park – 2 courts	1	LUMPSUM	\$	\$
	c. DeKalb Tennis Center – 17 courts	1	LUMPSUM	\$	\$
	d. Bouldercrest Park – 2 courts	1	LUMPSUM	\$	\$
	f. WD Thomson – 2 courts	1	LUMPSUM	\$	\$
	g. Midway Park – 2 courts	1	LUMPSUM	\$	\$
	h. Emory Grove Park – 2 courts	1	LUMPSUM	\$	\$
7	REPLACE NET POSTS AND NETS				
	a. Shoal Creek II – 4 courts	1	LUMPSUM	\$	\$
	b. Glen Emerald Park – 4 courts	1	LUMPSUM	\$	\$
	c. DeKalb Tennis Center – 17 courts	1	LUMPSUM	\$	\$
	d. Bouldercrest Park – 2 courts	1	LUMPSUM	\$	\$
	f. WD Thomson – 2 courts	1	LUMPSUM	\$	\$
	g. Midway Park – 2 courts	1	LUMPSUM	\$	\$
	h. Emory Grove Park – 2 courts	1	LUMPSUM	\$	\$

8	REPLACE ANY SITE FURNISHINGS TO COURT AREA				
	a. Shoal Creek II – 4 courts	1	LUMPSUM		
	b. Glen Emerald Park – 4 courts	1	LUMPSUM	\$	\$
	c. DeKalb Tennis Center – 17 courts	1	LUMPSUM	\$	\$
	d. Bouldercrest Park – 2 courts	1	LUMPSUM	\$	\$
	f. WD Thomson – 2 courts	1	LUMPSUM	\$	\$
	g. Midway Park – 2 courts	1	LUMPSUM	\$	\$
	h. Emory Grove Park – 2 courts	1	LUMPSUM	\$	\$
9	CLEAN WORK AREA				
	a. Shoal Creek II – 4 courts	1	LUMPSUM	\$	\$
	b. Glen Emerald Park – 4 courts	1	LUMPSUM	\$	\$
	c. DeKalb Tennis Center – 17 courts	1	LUMPSUM	\$	\$
	d. Bouldercrest Park – 2 courts	1	LUMPSUM	\$	\$
	f. WD Thomson – 2 courts	1	LUMPSUM	\$	\$
	g. Midway Park – 2 courts	1	LUMPSUM	\$	\$
	h. Emory Grove Park – 2 courts	1	LUMPSUM	\$	\$
CRACK REPAIR (LINE ITEMS 10-12)					
10	PRESSURE WASH COURTS				
	b. Glen Emerald Park – 2 courts	1	LUMPSUM	\$	\$
	c. DeKalb Tennis Center – 17 courts	1	LUMPSUM	\$	\$
	d. Bouldercrest Park – 2 courts	1	LUMPSUM	\$	\$
11	FILL ALL STRUCTURAL CRACKS WITH E330 CRACK FILLER AND INSTALL MULTI LAYERED RITE WAY CRACK REPAIR SYSTEM OVER ALL STRUCTURAL CRACKS (1/16” or larger)				
	b. Glen Emerald Park – 2 courts	1360	LF	\$	\$
	c. DeKalb Tennis Center – 17 courts	7775	LF	\$	\$
	d. Bouldercrest Park – 2 courts	949	LF	\$	\$
12	FILL ALL LOW LYING AREAS AND PAVING JOINTS WITH AN ACRYLIC BINDER PATCHING MIX				
	b. Glen Emerald Park – 2 courts	6	EACH	\$	\$
	c. DeKalb Tennis Center – 17 courts	19	EACH	\$	\$
	d. Bouldercrest Park – 2 courts	6	EACH	\$	\$

FULL COURT REPLACEMENT LINE ITEMS (13-19)

13	DEMOLITION OF 6 ½" OF COURT SURFACE				
	a. WD Thomson – 2 courts	1	LUMPSUM	\$	\$
	b. Midway Park – 2 courts	1	LUMPSUM	\$	\$
	c. Emory Grove Park – 2 courts	1	LUMPSUM	\$	\$
	e. Shoal Creek II Park – 4 courts	1	LUMPSUM	\$	\$
14	ADDITIONAL SUBBASE MATERIAL TO REACH A MINIMUM OF 12"				
	a. WD Thomson – 2 courts	1	LUMPSUM	\$	\$
	b. Midway Park – 2 courts	1	LUMPSUM	\$	\$
	c. Emory Grove Park – 2 courts	1	LUMPSUM	\$	\$
	e. Shoal Creek II Park – 4 courts	1	LUMPSUM	\$	\$
15	4" OF SUBBASE MATERIAL				
	a. WD Thomson – 2 courts	1	LUMPSUM	\$	\$
	b. Midway Park – 2 courts	1	LUMPSUM	\$	\$
	c. Emory Grove Park – 2 courts	1	LUMPSUM	\$	\$
	e. Shoal Creek II Park – 4 courts	1	LUMPSUM	\$	\$
16	1 ½" TYPE B BITUMINIOUS				
	a. WD Thomson – 2 courts	1	LUMPSUM	\$	\$
	b. Midway Park – 2 courts	1	LUMPSUM	\$	\$
	c. Emory Grove Park – 2 courts	1	LUMPSUM	\$	\$
	e. Shoal Creek II Park – 4 courts	1	LUMPSUM	\$	\$
17	TACK COAT LAYER				
	a. WD Thomson – 2 courts	1	LUMPSUM	\$	\$
	b. Midway Park – 2 courts	1	LUMPSUM	\$	\$
	c. Emory Grove Park – 2 courts	1	LUMPSUM	\$	\$
	e. Shoal Creek II Park – 4 courts	1	LUMPSUM	\$	\$
18	1" TYPE F BITUMINIOUS				
	a. WD Thomson – 2 courts	1	LUMPSUM	\$	\$
	b. Midway Park – 2 courts	1	LUMPSUM	\$	\$
	c. Emory Grove Park – 2 courts	1	LUMPSUM	\$	\$
	e. Shoal Creek II Park – 4 courts	1	LUMPSUM	\$	\$

19		FENCE REPLACEMENT			
	a. Shoal Creek II – 4 courts	1	LUMPSUM	\$	\$
	b. Midway – 2 courts	1	LUMPSUM	\$	\$
	c. WD Thomson – 2 courts	1	LUMPSUM	\$	\$
	d. Emory Grove – 2 courts	1	LUMPSUM	\$	\$
20	FILL ALL STRUCTURAL CRACKS WITH E330 CRACK FILLER AND INSTALL MULTI LAYERED RITE WAY CRACK REPAIR SYSTEM OVER ALL STRUCTURAL CRACKS (1/16" or larger)		Per LF	\$	\$
21	FILL ALL LOW LYING AREAS AND PAVING JOINTS WITH AN ACRYLIC BINDER PATCHING MIX		EACH	\$	\$
TOTAL BASE BID					\$

ATTACHMENT B
BID ACKNOWLEDGEMENT FORM

I, the undersigned, acknowledge that I have read the Bid Document in its entirety and agree to conform to its every requirement. I further acknowledge that failure to prepare, submit, or execute this bid in the exact manner requested will be just cause to reject my entire bid.

Name of Business Entity Submitting Bid

Print Name and Title of Authorized Signer

Business Entity Street Address

Authorized Signature

Business Entity City, State and Zip Code

Contact Person's Phone Number

Business Entity County

Contact Person's E-mail Address

- Bidder acknowledges addendum(s): No. 1 __, No. 2 __, No. 3 __ (If Applicable)
_____ (Initial)
- Bidder acknowledges that this bid is valid for 90 days from and including
_____ (Initial)
the bid opening date.
- Bidder acknowledges that bid meets or exceeds minimum specifications.
_____ (Initial)
Any deviation from minimum specifications must be explained, in detail,
by bidder as to how the bid does not meet the exact specifications.
- Bidder acknowledgement of Revisions to the above Terms and Conditions:
 - No revisions
_____ (Initial)
 - There are revisions and they are included with the bid submittal
_____ (Initial)

The above acknowledgment must be properly signed and firmly attached to your bid. The acknowledgment becomes a part of your bid and without it your bid is not be complete and will be subject to rejection.

ATTACHMENT C CONTRACTOR REFERENCE AND RELEASE FORM

List below at least three (3) references, including company name, contact name, address, email address, telephone numbers and contract period who can verify your experience and ability to perform the type(s) of product(s)/ service(s) listed in the solicitation.

Company Name	Contract Period		
Contact Person Name and Title	Telephone Number (include area code)		
Complete Primary Address	City	State	Zip Code
Email Address	Fax Number (include area code)		
Project Name and Description			

Company Name	Contract Period		
Contact Person Name and Title	Telephone Number (include area code)		
Complete Primary Address	City	State	Zip Code
Email Address	Fax Number (include area code)		
Project Name and Description			

Company Name	Contract Period		
Contact Person Name and Title	Telephone Number (include area code)		
Complete Primary Address	City	State	Zip Code
Email Address	Fax Number (include area code)		
Project Name and Description			

REFERENCE CHECK RELEASE STATEMENT

You are authorized to contact the references provided above for purposes of this ITB.

Signed _____ Title _____
(Authorized Signature of Bidder)

Company Name _____ Date _____

**ATTACHMENT D
SUBCONTRACTOR REFERENCE AND RELEASE FORM**

List below at least three (3) references, including company name, contact name, address, email address, telephone numbers and contract period who can verify your experience and ability to perform the type(s) of product(s)/ service(s) listed in the solicitation.

Company Name	Contract Period		
Contact Person Name and Title	Telephone Number (include area code)		
Complete Primary Address	City	State	Zip Code
Email Address	Fax Number (include area code)		
Project Name and Description			

Company Name	Contract Period		
Contact Person Name and Title	Telephone Number (include area code)		
Complete Primary Address	City	State	Zip Code
Email Address	Fax Number (include area code)		
Project Name and Description			

Company Name	Contract Period		
Contact Person Name and Title	Telephone Number (include area code)		
Complete Primary Address	City	State	Zip Code
Email Address	Fax Number (include area code)		
Project Name and Description			

REFERENCE CHECK RELEASE STATEMENT

You are authorized to contact the references provided above for purposes of this ITB.

Signed _____ Title _____
(Authorized Signature of Bidder)

Company Name _____ Date _____

ATTACHMENT E
CONTRACTOR & SUBCONTRACTOR EVIDENCE OF COMPLIANCE:

- (1) County contracts for the physical performance of services within the state of Georgia shall include the following provisions:¹
 - a. the contractor has registered with and is authorized to use the federal work authorization program to verify information on all newly hired employees or subcontractors;
 - b. by affidavit, the contractor must attest to the contractor's name, address, user identification number, date of authorization, and verification of the continual participation throughout the contract period, and
 - c. the affidavit shall become a part of the covered contract and must be attached.
- (2) No contractor or subcontractor who enters into a contract with the County shall enter into such a contract or subcontract in connection with the physical performance of services within Georgia unless the contractor or subcontractor registers and participates in the federal work authorization program to verify information of all newly hired employees. Any employee, contractor, or subcontractor of such contractor or subcontractor shall also be required to satisfy the requirements of O.C.G.A. § 13-10-91, as amended.
- (3) Upon contracting with a new subcontractor, a contractor or subcontractor shall, as a condition of any contract or subcontract entered into pursuant to O.C.G.A. § 13-10-91, as amended, agree to provide the County with notice of the identity of any and all subsequent subcontractors hired or contracted by the contractor or subcontractor. Such notice shall be provided within five (5) business days of entering into a contract or agreement for hire with any subcontractor. Such notice shall include an affidavit from each subsequent contractor attesting to the subcontractor's name, address, user identification number, and date of authorization to use the federal work authorization program.
- (4) An affidavit shall be considered an open public record; provided, however, that any information protected from public disclosure by federal law or by Article 4 of Chapter 28 of Title 50 shall be redacted. Affidavits shall be maintained by the County for five years from the date of receipt.
- (5) To verify compliance, the contractor agrees to participate in random audits conducted by the Commissioner of the Georgia Department of Labor. The results of the audits shall be published on the www.open.georgia.gov website, and on the Department of Labor's website no later than December 31 of each year.
- (6) Any person who knowingly and willfully makes a false, fictitious, or fraudulent statement in an affidavit submitted pursuant to O.C.G.A. § 13-10-91 shall be guilty of a violation of Code § 16-10-20 and, upon conviction, shall be punished as provided in such section. Contractors and subcontractors convicted for false statements based on a violation of such section shall be prohibited from bidding on or entering into any public contract for twelve (12) months following such conviction.

¹ O.C.G.A. § 13-10-91, as amended

**ATTACHMENT F
CONTRACTOR AFFIDAVIT**

By executing this affidavit, the undersigned verifies its compliance with O.C.G.A. § 13-10-91, as amended, stating affirmatively that the individual, firm or corporation which is contracting with DEKALB COUNTY, GA, a political subdivision of the State of Georgia, has registered with and is participating in a federal work authorization program* [any of the electronic verification of work authorization programs operated by the United States Department of Homeland Security or any equivalent federal work authorization program operated by the United States Department of Homeland Security to verify information of newly hired employees, pursuant to the Immigration Reform and Control Act of 1986 (IRCA), P.L. 99-603, in accordance with the applicability provisions and deadlines established in O.C.G.A. § 13-10-91, as amended]. The affiant agrees to continue to use the federal work authorization program throughout the contract period.

The undersigned further agrees that, should it employ or contract with any subcontractor(s) in connection with the physical performance of services pursuant to this contract with the COUNTY, contractor will secure from such subcontractor(s) similar verification of compliance with O.C.G.A. § 13-10-91, as amended, on the Subcontractor Affidavit form. Contractor further agrees to maintain records of such compliance and provide a copy of each such verification to the COUNTY, within five (5) days from when the subcontractor(s) is retained to perform such service.

BY: Authorized Officer or Agent
(Bidder's Name)

Federal Work Authorization
Enrollment Date

Title of Authorized Officer or Agent of Bidder

Identification Number

Printed Name of Authorized Officer or Agent

Address (* do not include a post office box)

SUBSCRIBED AND SWORN
BEFORE ME ON THIS THE

_____ DAY OF _____, 20__

Notary Public

My Commission Expires: _____

**ATTACHMENT G
SUBCONTRACTOR AFFIDAVIT**

By executing this affidavit, the undersigned verifies its compliance with O.C.G.A. § 13-10-91, as amended, stating affirmatively that the individual, firm, or corporation which is engaged in the physical performance of services under a contract with _____ name of contractor) on behalf of DEKALB COUNTY, GA, a political subdivision of the State of Georgia, has registered with and is participating in a federal work authorization program* [any of the electronic verification of work authorization programs operated by the United States Department of Homeland Security or any equivalent federal work authorization program operated by the United States Department of Homeland Security to verify information of newly hired employees, pursuant to the Immigration Reform and Control Act of 1986 (IRCA), P.L. 99-603, in accordance with the applicability provisions and deadlines established in O.C.G.A. § 13-10-91, as amended]. The affiant agrees to continue to use the federal work authorization program throughout the contract period.]

BY: Authorized Officer or Agent
(Bidder's Name)

Federal Work Authorization
Enrollment Date

Title of Authorized Officer or Agent of Bidder

Identification Number

Printed Name of Authorized Officer or Agent

Address (* do not include a post office box)

SUBSCRIBED AND SWORN
BEFORE ME ON THIS THE

_____ DAY OF _____, 20__

Notary Public
My Commission Expires: _____

ATTACHMENT H
DEKALB FIRST LSBE INFORMATION WITH EXHIBITS A – B

**SCHEDULE OF LOCAL SMALL BUSINESS ENTERPRISE PARTICIPATION
OPPORTUNITY TRACKING FORM**

The Chief Executive Officer and the Board of Commissioners of DeKalb County believe that it is important to encourage the participation of small and local businesses in the continuing business of County government; and that the participation of these types of businesses in procurement will strengthen the overall economic fabric of DeKalb County, contribute to the County’s economy and tax base, and provide employment to local residents. Therefore, the Chief Executive Officer and the Board of Commissioners have made the success of local small businesses a permanent goal of DeKalb County by implementing the DeKalb First Local Small Business Enterprise Ordinance.

PROVISIONS OF DEKALB FIRST LOCAL SMALL BUSINESS ENTERPRISE (LSBE) ORDINANCE

Percentage of LSBE Participation Required
20% of Total Award

Certification Designation	Request For Proposals (RFP)
LSBE Within DeKalb (LSBE-DeKalb)	Ten (10) Preference Points
LSBE Outside DeKalb (LSBE-MSA)	Five (5) Preference Points
Demonstrated GFE	Two (2) Preference Points

Certified Local Small Business Enterprises (LSBEs) located within DeKalb County and prime contractors utilizing LSBEs that are locally-based inside DeKalb County shall receive ten (10) points in the initial evaluation of their response to any Request for Proposal. Certified LSBEs located outside of DeKalb County but within the nine (9) County Metropolitan Statistical Area (MSA) consisting of Cherokee, Clayton, Cobb, Douglas, Fayette, Fulton, Gwinnett, Henry and Rockdale Counties shall receive five (5) points in the initial evaluation of their response to any Request for Proposal. Prime Contractors who demonstrate sufficient good faith efforts in accordance with the requirements of the ordinance shall be granted two (2) points in their initial evaluation of responses to any Request for Proposal. Pro-rated points shall be granted where a mixture of LSBE-DeKalb and LSBE MSA firms are utilized. Utilization of each firm shall be based upon the terms of the qualified sealed solicitation.

Prime Contractor(s) deemed responsible and remains responsive to an Invitation to Bid (ITB) because they are either a certified LSBE-DeKalb or LSBE-MSA firm or has obtained 20% participation of an LSBE-DeKalb or LSBE-MSA firm, submits the lowest bid price shall be deemed the lowest, responsive and responsible bidder.

Prime Contractor(s) deemed responsible and remains responsive to an Invitation to Bid (ITB) and documented good faith efforts, submits a lower bid price than a Prime Contractor that achieved 20% LSBE participation, or otherwise required benchmark, then the Prime Contractor who actually met the benchmark will be given the opportunity to match the lowest bid price of the Prime Contractor who only made good faith efforts. Prime Contractor(s) who choose **not** to match the lowest bid price, then the Prime Contractor who made the good faith efforts will be deemed the lowest, responsive and responsible bidder.

For all qualified sealed solicitations, the Director of Purchasing and Contracting, DeKalb County Government, shall determine if the bidder/proposer has included written documentation showing that at least twenty percent (20%) of the total contract award will be performed by a certified LSBE. This written documentation shall be in the form of a notarized Schedule of LSBE Participation (Attached hereto as “Exhibit A”.) For all contracts, a signed letter of intent from all certified LSBEs describing the work, material, equipment and/or services to be performed or provided by the LSBE(s) and the agreed upon percentage shall be due with the bid or proposal

documents and included with “Exhibit A”. The certified vendor list establishes the group of Certified LSBE’s from which the bidder/proposer must solicit subcontractors for LSBE participation. This list can be found on our website <http://www.dekalbcountyga.gov/purchasing-contracting/about-purchasing-and-contracting> or obtained from the Special Projects LSBE Program team.

Prime Contractors failing to meet the LSBE benchmark must document and demonstrate Good Faith Efforts in accordance with the attached “Checklist for Good Faith Efforts” portion of “Exhibit A.” The notarized Schedule of LSBE Participation shall be due and submitted with each bid or proposal. Failure to achieve the LSBE benchmark or demonstrate good faith efforts shall result in a bid or proposal being rejected. Prime Contractors that fail to attend the mandatory LSBE meeting in person or via video conference shall mean that the Prime Contractor has not demonstrated sufficient good faith efforts and its bid or proposal if submitted, shall be deemed non-responsive without any further review.

Upon award, Prime Contractors are required to submit a report detailing LSBE Sub-Contractor usage with each request for payment and not less than on a monthly basis. Prime Contractors shall ensure that all LSBE sub-contractors have been paid within seven (7) days of the Prime’s receipt of payment from the County. Failure to provide requested reports/documentation shall constitute a material breach of contract, entitling the County to terminate the Contract for default or pursue other remedies. LSBE sub-contractors must confirm payments received from the Prime(s) for each County contract they participate in.

For eligible bids/proposals valued over \$5,000,000.00, the Mentor-Protégé provision of the Ordinance shall apply. Prime Contractors must agree to become mentors and take on an LSBE protégé in an effort to enhance the potential of future LSBEs. Qualifying projects shall be performed by both Mentor and Protégé through a subcontract between both parties. This requirement is in addition to all other applicable sections of the DeKalb First Ordinance. Please review the ordinance, section 2-214 or contact the LSBE Program Representative for detailed information regarding this initiative.

EXHIBIT A
SCHEDULE OF DEKALB FIRST LOCAL SMALL BUSINESS ENTERPRISE PARTICIPATION
OPPORTUNITY TRACKING FORM

As specified, Bidders and Proposers are to present the details of LSBE participation below:

PRIME BIDDER/PROPOSER _____

SOLICITATION NUMBER: **20-101299**

TITLE OF UNIT OF WORK – **Tennis Courts Repair and Replacement**

1. My firm, as the prime bidder/proposer on this unit of work, is a certified (check all that apply):
 LSBE-DeKalb LSBE-MSA

2. If you are a Certified LSBE-DeKalb or MSA, please indicate below the percentage of that your firm will carry out directly: _____.

3. If the prime bidder/proposer is a joint venture, please describe below the nature of the joint venture and level of work and percentage of participation to be provided by the LSBE-DeKalb or MSA joint venture firm.

4. List the LSBE-DeKalb or MSA subcontractors and/or firms (including suppliers) to be utilized in of this contract, if awarded. No changes can be made in the subcontractors listed below without the prior written approval of the County. Please attach a signed letter of intent from all certified LSBEs describing the work, materials, equipment or services to be performed and/or provided and the agreed upon percentage of work to be performed. A Letter of Intent form is attached hereto as “Exhibit B”.

Name of Company	
Address	
Telephone	
Fax	
Contact Person	
Indicate certification status and attach proof of certification: LSBE-DeKalb/LSBE-MSA	
Description of services to be performed	
Percentage of work to be performed	

Name of Company	
Address	
Telephone	
Fax	
Contact Person	
Indicate certification status and attach proof of certification: LSBE-DeKalb/LSBE-MSA	

Description of services to be performed	
Percentage of work to be performed	

Name of Company	
Address	
Telephone	
Fax	
Contact Person	
Indicate certification status and attach proof of certification: LSBE-DeKalb/LSBE-MSA	
Description of services to be performed	
Percentage of work to be performed	

Name of Company	
Address	
Telephone	
Fax	
Contact Person	
Indicate certification status and attach proof of certification: LSBE-DeKalb/LSBE-MSA	
Description of services to be performed	
Percentage of work to be performed	

Name of Company	
Address	
Telephone	
Fax	
Contact Person	
Indicate certification status and attach proof of certification: LSBE-DeKalb/LSBE-MSA	
Description of services to be performed	
Percentage of work to be performed	

Please attach additional pages, if necessary.

EXHIBIT A, CONT'D
DEKALB COUNTY
CHECKLIST FOR GOOD FAITH EFFORTS

A bidder/proposer that does not meet the County's LSBE participation benchmark is required to submit documentation to support all "Yes" responses as proof of "good faith efforts." Please indicate whether or not any of these actions were taken:

	Yes	No	Description of Actions
1.			Prime Contractors shall attend a MANDATORY LSBE Meeting in person or via video conference within two-weeks of advertisement of the solicitation.
2.			Provide a contact log showing the company's name, contact person, address, email and contact number (phone or fax) used to contact the proposed certified subcontractors, nature of work requested for quote, date of contact, the name and title of the person making the effort, response date and the percentage of work.
3.			Provide interested LSBEs via email, of any new relevant information, if any, at least 5 business days prior to submission of the bid or proposal.
4.			Efforts made to divide the work for LSBE subcontracting areas likely to be successful and to identify portions of work available to LSBEs consistent with their availability. Include a list of divisions of work not subcontracted and the corresponding reasons for not including them. The ability or desire of a bidder/proposer to perform the contract work with its own organization does not relieve it of the responsibility to make good faith efforts on all scopes of work subject to subcontracting.
5.			Efforts were made to assist potential LSBE subcontractors meet bonding, insurance, or other governmental contracting requirements. Where feasible, facilitating the leasing of supplies or equipment when they are of such a specialized nature that the LSBE could not readily and economically obtain them in the marketplace.
6.			Communication via email or phone with DeKalb First Program Staff seeking assistance in identifying available LSBEs. Provide DeKalb First Program Staff representative name and title, and date of contact.
7.			For all contracts, a signed letter of intent from all certified LSBEs describing the work, materials, equipment or services to be performed or provided by the LSBE(s) and the agreed upon LSBE participation percentage shall be due with the bid or proposal documents.
8.			Other Actions, to include Mentor/Protégé commitment for solicitations \$5M and above (specify):

Please explain all "no" answers above (by number):

This list is a guideline and by no means exhaustive. The County will review these efforts, along with attached supporting documents, to assess the bidder/proposer's efforts to meet the County's LSBE Participation benchmark. If you require assistance in identifying certified, bona fide LSBEs, please contact the Purchasing and Contracting Department - DeKalb First Program, DeKalbFirstLSBE@dekalbcountyga.gov or (404) 371-4770.

EXHIBIT A, CONT'D

DEKALB FIRST LOCAL SMALL BUSINESS ENTERPRISE SCHEDULE OF PARTICIPATION OPPORTUNITY TRACKING FORM

Bidder/Proposer Statement of Compliance

Bidder(s)/Proposer(s) hereby state that they have read and understand the requirements and conditions as set forth in the objectives and that reasonable effort were made to support the County in providing the maximum practicable opportunity for the utilization of LSBEs consistent with the efficient and economical performance of this contract. The Bidder and any subcontractors shall file compliance reports at reasonable times and intervals with the County in the form and to the extent prescribed by the Director of DeKalb County Purchasing and Contracting Department. Compliance reports filed at such times as directed shall contain information as to the employment practices, policies, programs and statistics of Contractors and their subcontractors.

1. **Non-Discrimination Policy**

- a. During the performance of this agreement, Contractor agrees to conform to the following Non-Discrimination Policy adopted by the County.
- b. Contractor shall not discriminate against any employee or applicant for employment because of race, color, religion, sex, national origin, or disability. The Contractor will take action to ensure that applicants are employed, and the employees are treated during employment without regard to their race, color, religion, sex, national origin, or disability. Such action shall include, but not be limited to, the following:
 - (1) Employment, upgrading, demotion or transfer; recruitment or recruitment advertising; layoff or termination; rates of pay or other forms of compensation; and selection for training, including apprenticeship. Contractor agrees to post in conspicuous places available to employees and applicants for employment, notices to be provided setting forth provisions of this non-discrimination clause.
 - (2) Contractor shall, in all solicitations or advertisements for employees placed by or on behalf of Contractor, state that all qualified applicants will receive consideration for employment without regard to race, color, religion, sex, national origin, or disability.
- c. Without limiting the foregoing, Contractor shall not discriminate on the basis of disability in the admission or access to, or treatment or employment in, the programs and activities, which form the subject of the contract. The Contractor will take action to ensure that applicants for participation in such programs and activities are considered without regard to disability. Such action shall include, but not be limited to, the following:
 - (1) Contractor agrees to post in conspicuous places available to participants in its programs and activities notices to be provided setting forth the provisions of this non-discrimination clause.
 - (2) Contractor shall, in all solicitations or advertisements for programs or activities, which are the subject of the contract, state that all qualified applicants will receive consideration for participation without regard to disability.

2. **Commitment**

The undersigned certifies that he/she has read, understands, and agrees to be bound by the bid specifications, including the accompanying Exhibits and other terms and conditions of the Invitation to Bid and/or Request for Proposal regarding LSBE utilization. The undersigned further certifies that he/she is legally authorized by the bidder or responder to make the statements and representations in Exhibit A and that said statements and representations are true and correct to the best of his/her knowledge and belief. The undersigned will enter into formal agreement(s) with the LSBE(s) listed in this Exhibit A, which are deemed by the owner to be legitimate and responsible LSBEs. Said agreement(s) shall be for the work and contract with the Prime Contractor. The undersigned understands and agrees that if any of the statements and representations are made by the Bidder

knowing them to be false, or if there is a failure of the successful Bidder (i.e., Contractor) to implement any of the stated agreements, intentions, objectives, goals and commitments set forth herein without prior approval of the County, then in any such events the contractor's act or failure to act, as the case may be, shall constitute a material breach of contract, entitling the County to terminate the Contract for default. The right to so terminate shall be in addition to, and not in lieu of, any other rights and remedies the County may have for other defaults under the Contract. Additionally, the Contractor will be subject to the loss of any future contract awards by the County for a period of one year.

Firm Name (Please Print):

Firm's Officer:

(Authorized Signature and Title Required) Date

Sworn to and Subscribed to before me this ____ day of _____, 201__.

Notary Public

My Commission Expires: _____

EXHIBIT B
LETTER OF INTENT TO PERFORM AS A SUBCONTRACTOR
PROVIDING MATERIALS OR SERVICES

Instructions:

1. Complete the form in its entirety and submit with bid documents.
2. Attach a copy of the LSBE's current valid Certification Letter.

To: _____

(Name of Prime Contractor Firm)

From: _____

(Name of Subcontractor Firm)

LSBE –DeKalb **LSBE –MSA**

(Check all that apply)

ITB Number: 20-101299

Project Name: Tennis Courts Repair and Replacement

The undersigned subcontractor is prepared to perform the following described work or provide materials or services in connection with the above project (specify in detail particular work items, materials, or services to be performed or provided).

Description of Materials or Services	Project/Task Assignment	% of Contract Award

Prime Contractor

Sub-contractor

Signature: _____

Signature: _____

Title: _____

Title: _____

Date: _____

Date: _____

ATTACHMENT I

FIRST SOURCE JOBS ORDINANCE INFORMATION

(WITH EXHIBITS 1 – 4)

EXHIBIT 1

First Source Jobs Ordinance Acknowledgement

The DeKalb County First Source Ordinance requires contractors or beneficiaries of eligible projects entering into any type of agreement with the County, including purchase orders, regardless of what they may be called, for the procurement or disposal of supplies, services, construction projects, professional or consultant services, which is funded in whole or part with County funds or County administered funds in which the contractor is to receive \$50,000 or more in County expenditures or committed expenditures and recipient of urban redevelopment action grants or community development block funds administered in the amount of \$50,000 or more to make a good faith effort to hire DeKalb County residents for at least 50% of jobs created using the First Source Registry (candidate database) within one hundred twenty (120) days of contract execution. The work to be performed under this contract is subject to the provisions of the DeKalb County First Source Jobs Ordinance. All contractors will be asked to submit an **Employment Roster** and/or copies of active payroll registers on a monthly basis to verify compliance. The undersigned acknowledges and agrees to comply with the provisions of the DeKalb County First Source Jobs Ordinance.

CONTRACTOR OR BENEFICIARY INFORMATION:

 Contractor or Beneficiary Name (Signature)

 Contractor or Beneficiary Name (Printed)

 Title

 Telephone

 Email

 Name of Business

Please answer the following questions:

1. How many job openings do you anticipate filling related to this contract? _____
2. How many incumbents/existing employees will retain jobs due to this contract?
 DeKalb Residents: _____ Non-DeKalb Residents: _____
3. How many work hours per week constitutes Full Time employment? _____

Please return this form to WorkSource DeKalb, (404)687-3900 or email to fkadkins@dekalbcountyga.gov, malee@dekalbcountyga.gov, vlricksion@dekalbcountyga.gov, or jmjones@dekalbcountyga.gov

Exhibit 2
NEW EMPLOYEE TRACKING FORM

Name of Bidder _____

Address _____

E-Mail _____

Phone Number _____

Fax Number _____

Do you anticipate hiring from the First Source Candidate Registry? Y or N (Circle one)

If so, the approximate number of employees you anticipate hiring: _____

Type of Position (s) you anticipate hiring: (List position title, one position per line) Attach job description per job title:	The number you anticipate hiring:	Timeline

Please return this form to WorkSource DeKalb, fax (404) 687-4099 or email to
FirstSourceJobs@dekalbcountyga.gov.

FIRST SOURCE JOBS ORDINANCE INFORMATION

EXHIBIT 3

BUSINESS SERVICE REQUEST FORM

note: We need one form completed for each position that you have available.

FEDERAL TAX ID:

COMPANY NAME:

WEBSITE:

ADDRESS:

(WORKSITE ADDRESS IF DIFFERENT):

CONTACT NAME:

CONTACT PHONE:

CONTACT FAX:

CONTACT E-MAIL ADDRESS:

Are you a private employment agency or staffing agency? YES NO

JOB DESCRIPTION: (PLEASE INCLUDE A COPY OF JOB DESCRIPTION)

POSITION TITLE:

NUMBER OF POSITIONS AVAILABLE: _____ **TARGET START DATE:** _____

WEEKLY WORK HOURS: 20-30 hours 30-40 hours Other

SPECIFIC WORK SCHEDULE:

SALARY RATE(OR RANGE):

PERM TEMP TEMP-TO-PERM SEASONAL

PUBLIC TRANSPORTATION ACCESSIBILITY YES NO

IF SCREENINGS ARE REQUIRED, SELECT ALL THAT APPLY:

CREDIT DRUG MVR BACKGROUND OTHER _____

Please return form to: **Business Solutions Unit (First Source)**

774 Jordan Lane Bldg. #4

Decatur, Ga. 30033

Phone: (404) 687-3400

FirstSourceJobs@dekalbcountyga.gov

**EXHIBIT 4
EMPLOYMENT ROSTER
DeKalb County**

Contract Number: _____
Project Name: _____
Contractor: _____ **Date:** _____

Name	Position:	Start Date	Hourly Rate of Pay	Hired for this Project? (yes/no)	Anticipated Length of Employment (Months)	% of Time Dedicated to the Project	Full or Part Time? (No. of Hours)	Georgia County of Residency

ATTACHMENT J
SITE VISIT ACKNOWLEDGEMENT

I hereby acknowledge I have visited ALL Sites identified on the Schedule of Site Items for which I am providing a bid amount. I further state I have a full understanding of the performance requirements of this solicitation for the sites I have submitted a bid amount.

COMPANY NAME: _____

NAME & TITLE (print): _____

SIGNATURE: _____

ATTACHMENT K REQUIRED DOCUMENTS CHECKLIST

Bidder shall complete and submit the following documents with their bid:

Bid Page No.	Title	Check This Box If Included With Bid
3	One Original, Two Copies of the entire ITB	
8	Delivery*	
9	Foreign Products*	
9	Warranty / Guaranty*	
38-42	Bid Price Schedule	
43	Bid Acknowledgement Form*	
44	Contractor Reference and Release Form*	
45	Subcontractor Reference and Release Form, if applicable**	
47	Contractor Affidavit*	
48	Subcontractor Affidavit, if applicable**	
49-57	LSBE - Exhibits A and/or B of Attachment G*	
58	First Source Jobs Acknowledgement Form *	
59	New Employee Tracking Form*	
62	Site Acknowledement Form*	
63	Required Documents Checklist*	

***If these mandatory forms are not completed and submitted with the bid, the bidder will be deemed non-responsive.**

****These forms are applicable if a subcontractor will be utilized to fulfill the requirements of this contract. If these forms are applicable, they must be completed and submitted along with the bid. Failure to submit these forms, if applicable, will result in the bidder being deemed non-responsive.**

I, the undersigned, acknowledge that I have included the requested documents as listed above.

Printed Name

Signature