



Lorraine Cochran-Johnson

Chief Executive Officer

DeKalb County Zoning Board of Appeals
Department of Planning & Sustainability
178 Sams Street,
Decatur, GA 30030

Wednesday, April 8, 2025

Planning Department Staff Analysis



Juliana Njoku

Director

N3. Case No: A-25-1247991

Parcel ID(s): 18 054 09 032

Commission District 02 Super District 06

Applicant: Dan Hanlon
2025 Tuxedo Avenue NE
Atlanta, GA 30307

Owner: Molly Cummings
1282 Oxford Road
Atlanta, GA 30306

Project Name: 1282 Oxford Road - Rear Yard Improvements

Location: 1282 Oxford Road, Atlanta, GA 30306

Requests: Variance request from Section 27-2.2.1 of the DeKalb County Zoning Ordinance to increase the maximum lot coverage from 35 percent to 61 percent (Currently 64.8%) to facilitate rear yard improvements including removal of a failed pool, surrounding deck and walls, and a non-historic gazebo, and construction of a new pool, open-air pool house, new pool decking and patios, and a modified driveway on property zoned R-75 (Residential Medium Lot) and within the Druid Hills Historic District.

Staff Recommendation: Approval with Conditions

Recommended Conditions if Approved:

- 1. The following information about this variance shall be noted on any site plan prepared for the subject property: case number, approval date, type of variance and condition(s) of approval.

STAFF FINDINGS:

The subject property is a 0.31-acre residential parcel located at 1282 Oxford Road, zoned R-75 and designated Traditional Neighborhood, within the Druid Hills Historic overlay. The application states that the property contains a 1929 house with several later additions, including a pool and related improvements permitted in the 1990s. The owner proposes to remove a failed pool, surrounding deck and walls, and a non-historic gazebo, and replace those elements with a new pool, an open-air pool house, new decking and patios, and a modified driveway. The submitted site plan shows existing lot coverage at approximately 64.58% percent and proposed lot coverage at approximately 60.95 percent, which remains above the 35 percent maximum but represents a reduction from existing conditions.

1. There is an extraordinary or exceptional physical condition(s) pertaining to the particular piece of property (such as, but not limited to, lot size, lot shape, specimen tree(s), steep slope(s), or preservation of historic characteristics of the property), which was not created by the current owner, previous owner, or applicant; by reason of a clearly demonstrable condition(s), the strict application of the requirements of this chapter would deprive the property owner of rights and privileges enjoyed by other property owners in the same zoning district, as distinguished from a special privilege or convenience sought by the property owner.

The record reflects that the property has a long, narrow configuration and a rear yard layout that is shaped by the siting of the existing historic house and the need for a long driveway to access the back of the lot. The applicant also states that the house sits high up and well back from the street, which further distinguishes the site from a typical interior residential lot. While the existing nonconforming lot coverage is not, by itself, a physical hardship under the ordinance, staff finds that the lot geometry, site layout, and established historic development pattern create a constrained rear yard condition that is relevant to this request.

2. The requested variance does not go beyond the minimum necessary to afford relief, and does not constitute a grant of special privilege inconsistent with the limitations upon other properties in the zoning district in which the subject property is located:

Staff finds that the request is limited to the minimum necessary under the circumstances presented. While the proposal remains above the ordinance maximum, it reduces the degree of existing nonconformity and does not intensify site impacts relative to current conditions. Instead, the submitted plans reduce impervious coverage from approximately 64.58 percent to 60.95 percent. The applicant also identifies specific measures taken to lessen coverage, including reducing the pool size, adding grass strips in the driveway, and using paver grid treatment in portions of the deck area. Because the proposal slightly decreases existing coverage while allowing reinvestment in the rear yard, staff finds that strict application would deprive the owner of rights enjoyed by other R-75 properties

3. The grant of the variance will not be materially detrimental to the public welfare or injurious to the property or improvements in the zoning district in which the subject property is located:

Staff finds that the request is not likely to be materially detrimental to the public welfare. The work is concentrated in the rear of the property, and the application states that, because of the topography and house siting, the proposed improvements will have minimal visual impact from the public right-of-way due to topography and siting. The submitted plans also include stormwater management measures, as shown on the submitted stormwater plan (Sheet C-2). In addition, the file includes a support sheet signed by four immediate neighbors stating that they have no issue with the requested increase to 61 percent. These factors support a finding that the proposal is not likely to injure nearby properties or the surrounding residential district.

4. The literal interpretation and strict application of the applicable provisions or requirements of this chapter would cause undue and unnecessary hardship:

Strict application of the 35 percent lot coverage standard would effectively prevent reasonable reinvestment in the property improvements unless the owner first removed substantially more of the already developed site. Staff finds that this would create an unnecessary hardship in light of the fact that the proposal reduces existing impervious coverage rather than increasing it. Denial would leave the property in a more nonconforming condition than the one proposed and would limit the owner's ability to replace a failed pool and related improvements with a less intensive arrangement. Under these particular facts, staff finds that strict application of the ordinance would cause an undue hardship. The property contains longstanding legally nonconforming lot coverage established through prior permitted improvements. This condition, combined with the site layout, limits the owner's ability to make reasonable reinvestment without variance relief.

5. The requested variance would be consistent with the spirit and purpose of this Chapter and the DeKalb County Comprehensive Plan Text:

The subject property is within the Traditional Neighborhood character area and the Druid Hills Historic overlay. The application states that the proposed work is in keeping with the intent to preserve the style and appeal of older traditional neighborhoods, and that none of the relevant character area goals would be adversely affected because the work occurs in the rear of the lot. The proposal has received Historic Preservation Commission approval, indicating consistency with Druid Hills Historic District guidelines. Staff finds that the proposal is consistent with the spirit and purpose of the ordinance because it allows reinvestment in an existing historic residential property while slightly reducing lot coverage and maintaining compatibility with the surrounding neighborhood.

FINAL STAFF ANALYSIS:

The request is distinguishable from a typical overbuilding case because it reduces an existing legally nonconforming condition rather than intensifying it. The subject property contains longstanding impervious coverage established through prior permitted improvements, limiting the owner's ability to make reasonable reinvestment without variance relief. The proposal reduces coverage from approximately 64.6% to 60.9%, incorporates stormwater mitigation measures, and has received Historic Preservation Commission approval. Additionally, the improvements are confined to the rear yard and have minimal visibility from the public right-of-way. Given the site's configuration, existing development pattern, and reduced impact relative to current conditions, staff finds the request meets the variance criteria.

Staff Recommendation: Approval with Conditions

Conditions:

1. The following information about this variance shall be noted on any site plan prepared for the subject property: case number, approval date, type of variance and condition(s) of approval.

ZONING BOARD OF APPEALS (ZBA) APPLICATION
to Amend the Official Zoning Map of DeKalb County, Georgia

Subject Property Address: 1282 Oxford Road

City: Atlanta State: GA Zip: 30307

Parcel ID Number(s): 18 054 09032/0915785 Acreage: .312

District: 18 Land Lot: 54 Block: 38 Parcel: 23

Commission District(s): _____ Super District: _____

Type of Hearing Requested (check one):

- VARIANCE (from Development Standards causing undue hardship upon owners of property.)
- SPECIAL EXCEPTIONS (to Reduce or Waive off-street parking or loading space requirements.)
- OFFICIAL APPEAL OF ADMINISTRATIVE DECISIONS.

***PLEASE REVIEW THE FILING GUIDELINES ON PAGE 4.**

FAILURE TO FOLLOW GUIDELINES MAY RESULT IN SCHEDULING DELAYS.*

I hereby authorize the staff of the Planning and Sustainable Department to inspect the property that is the subject of this application.

Owner Agent

Dan Hanlon
Signature

2.5.26
Date

**ZONING BOARD OF APPEALS (ZBA) APPLICATION FEE:
\$300.00**

**DeKalb County does not require payment by wire transfer.
Be aware of scammers and fraudulent emails.**

Email plansustain@dekalbcountyga.gov with any questions

DEPARTMENT OF PLANNING & SUSTAINABILITY

ZONING BOARD OF APPEALS APPLICATION

AUTHORIZATION OF THE PROPERTY OWNER

I hereby authorize the staff and members of the Zoning Board of Appeals to inspect the premises of the Subject Property.

I hereby certify that the information provided in the application is true and correct.

I hereby certify that I am the owner of the property subject to the application.

DATE: 2/5/26 Applicant Signature: Macey L. Cummins

DATE: _____ Applicant Signature: _____

DEPARTMENT OF PLANNING & SUSTAINABILITY

ZONING BOARD OF APPEALS APPLICATION

AUTHORIZATION TO REPRESENT THE PROPERTY OWNER

I hereby authorize the staff and members of the Zoning Board of Appeals to inspect the premises of the Subject Property.

I hereby certify that the information provided in the application is true and correct.

I hereby certify that I am the owner of the property and that I authorize the applicant/agent to apply for a hearing to the Zoning Board of Appeals for the requests as shown in this application.

DATE: 2.5.26 Applicant/Agent Dan Hanlon
Signature: _____

TO WHOM IT MAY CONCERN:

(I)/ (WE): Molly Cummings
(Name of Owners) _____

being (owner/owners) of the property described below or attached hereby delegate authority to the above signed agent/applicant.

Notary Public

Molly L Cummings
Owner Signature

Notary Public

Owner Signature

Notary Public

Owner Signature



February 9th, 2026

DeKalb County
Department of Planning and Sustainability
330 West Ponce de Leon Avenue
Suite 300
Decatur, GA 30030

Re: 1282 Oxford Road

Planning Staff:

The owner of 1282 Oxford Road is seeking to improve the back portion of the property by removing a pool that has failed and is no longer usable, remove the surrounding pool deck and walls, remove a non-historic gazebo, and replace those elements with a new pool, an open air pool house structure, new pool decking and patios, and a new driveway. The current lot coverage is 64.58%. This is mostly due to multiple permitted projects being done in the 1990s.

The property is zoned R-75, with a 35% lot coverage limitation. We are requesting a variance from code section 27-2.2.1 of the DeKalb County Ordinance to increase lot coverage from 35% to 61%.

The property is located in the Druid Hills historic district, and we have received approval from the DCHPC.

Below is our justification for the project, based on the criteria for variance hardships.

Physical Conditions of the Site

The house was built in 1929, and has had several additions over the years. The permit history that is available shows that the pool (and presumably the pool deck and retaining walls) was permitted in 1990, and a house addition was permitted in 1997.

The property has traditional Druid Hills characteristics, with a long narrow lot, requiring a substantial driveway to get to the rear.

With the 1997 addition, the house has a large footprint of almost 2,300sf.

Minimum Variance Necessary

We have made reasonable efforts to reduce the current lot coverage. These include:

- Adding two grass strips in the new driveway
- Doing a portion of the pool deck in a paver grid with grass in between the stone
- Significantly reducing the size of the pool

Proposal is not materially detrimental to the public welfare or injurious to the property

The proposal includes a stormwater management, alleviating stormwater pressures on neighboring properties.

We have gathered letters of support for the project from four of the five immediate neighbors (we have provided the one neighbor that we were not able to connect with of the information about ZBA hearing). See attached.

Strict application of the code causes undue and unnecessary hardship

Yes, any meaningful addition/renovation to the property would require a variance due to legal non-conforming lot coverage conditions.

Proposal is consistent with the spirit and purpose of Section 7.5.1 and the DeKalb County Comprehensive Plan Text

The future land use designation of this property is Traditional Neighborhood, with the intent being to preserve the style and appeal of older traditional neighborhood communities. The goals include greater walkability, on-street parking, small, regular lots, and buildings closer to the front property line. None of these desired characteristics and goals would be impacted by this project. Because all of the work is in the rear of the house, because of the topography and house siting (the house sits high up, and well back of the street), there will be no visual impact to the neighborhood. We have received approval from the DCHPC, as the project conforms with Druid Hills aesthetics and functionality, and meets the neighborhood guidelines.

DEKALB COUNTY NOTES:

- GRADE TO DRAIN AWAY FROM FOUNDATION.
- ALL GRADED SLOPES TO BE AT A 3:1 SLOPE OR GREATER.
- ALL LAND DISTURBANCE TO BE STABILIZED WITH VEGETATION UPON COMPLETION OF DEMOLITION. ALL TREES TO REMAIN AND HAVE PROPER PROTECTION UNLESS APPROVED PLANS INDICATE OTHERWISE. CALL FOR FINAL INSPECTION AT 404-371-4913.
- ALL CONSTRUCTION MUST CONFORM TO DEKALB COUNTY STANDARDS.
- PRIOR TO COMMENCING LAND DISTURBING ACTIVITY, THE LIMITS OF DISTURBANCE SHALL BE CLEARLY AND ACCURATELY DEMARCATED WITH STAKES, RIBBONS OR OTHER APPROPRIATE MEANS, THE LOCATION AND EXTENT OF ALL AUTHORIZED LAND DISTURBING ACTIVITY SHALL BE DEMARCATED FOR THE DURATION OF THE CONSTRUCTION ACTIVITY.
- ALL EROSION CONTROL MEASURES SHALL BE IN PLACE PRIOR TO COMMENCING CONSTRUCTION AND SHALL BE MAINTAINED IN PROPER WORKING ORDER UNTIL ALL DISTURBED AREAS ARE STABILIZED.
- A COPY OF THE APPROVED LAND DISTURBANCE PLAN SHALL BE PRESENT ON SITE WHENEVER LAND DISTURBANCE ACTIVITY IS IN PROGRESS.
- FINAL ON-SITE INSPECTION REQUIRED PRIOR TO RELEASE OF THE CERTIFICATE OF OCCUPANCY, CERTIFIED AS-BUILTS WILL ALSO BE REQUIRED.
- EROSION AND SEDIMENTATION CONTROL MEASURES WILL BE MAINTAINED AT ALL TIMES. IF FULL IMPLEMENTATION OF THE APPROVED PLAN DOES NOT PROVIDE FOR EFFECTIVE EROSION AND SEDIMENT CONTROL, ADDITIONAL EROSION AND SEDIMENT CONTROL MEASURES SHALL BE IMPLEMENTED TO CONTROL OR TREAT THE SEDIMENT SOURCE.
- ADDITIONAL EROSION CONTROLS SHALL BE INSTALLED AS DEEMED NECESSARY BY THE IN-SITE INSPECTOR.
- ALL LOTS/SITES WITH 2' OF FILL OR GREATER WILL REQUIRE A COMPACTION CERTIFICATE BY A PROFESSIONAL REGISTERED ENGINEER PRIOR TO A BUILDING PERMIT AND OR PRIOR TO FOOTERS BEING POURED.
- LOCATE AND FIELD STAKE ALL UTILITIES, EASEMENTS, PIPES, FLOOD LIMITS, STREAM BUFFERS, AND TREE SAVE AREAS PRIOR TO ANY LAND DISTURBING ACTIVITIES.
- ALL TREE PROTECTION AREAS TO BE PROTECTED FROM SEDIMENTATION.
- ALL TREE PROTECTION DEVICES TO BE INSTALLED PRIOR TO LAND DISTURBANCE AND MAINTAINED UNTIL FINAL LANDSCAPING.
- ALL TREE PROTECTION FENCING TO BE INSPECTED DAILY AND REPAIRED OR REPLACED AS NEEDED.
- A FINAL AS-BUILT LOT SURVEY REQUIRED PRIOR TO ISSUANCE OF CERTIFICATE OF OCCUPANCY.
- A FINAL AS-BUILT WATER QUALITY CERTIFICATE REQUIRED PRIOR TO CERTIFICATE OF OCCUPANCY.
- WATER QUALITY BMP(S) TO BE INSTALLED AT THE TIME OF FINAL LANDSCAPING.
- ALL COLLECTED WATER SHALL BE DIRECTED TO THE WATER QUALITY BMP(S).
- WORK HOURS AND CONSTRUCTION DELIVERIES ARE:
MONDAY-FRIDAY 7:00am-7:00pm
SATURDAY 8:00am-5:00pm
- ALL DEMOLITION DEBRIS TO BE HAULED OFF SITE
- DUMPSTERS AND/OR TEMPORARY SANITARY FACILITIES SHALL NOT BE LOCATED IN STREET OR TREE PROTECTION AREA, OR RIGHT OF WAY.

GENERAL DEMOLITION NOTES:

BE ADVISED THIS IS NOT AN EXHAUSTIVE LIST OF DEMOLITION ITEMS. CONTRACTOR SHALL BECOME FAMILIAR WITH THE SITE AND THE COMPLETE DESIGN INTENT OF THE CONSTRUCTION DOCUMENTS. ANY QUESTIONS, CONCERNS, OR IDEAS CONCERNING THE INTENT OR EXECUTION OF THE DESIGN DOCUMENTS MUST BE BROUGHT TO THE OWNER BEFORE PERFORMING ANY CONSTRUCTION ACTIVITY.

- REMOVE EXISTING POOL AND POOL PATIO IN PREPARATION FOR THE PROPOSED POOL
- REMOVE EXISTING EXISTING GAZEBO AND PAVERS
- REMOVE PORTION OF EXISTING CONCRETE IN BEHIND EXISTING ONE STORY FRAME GARAGE
- REMOVE EXISTING CONCRETE BORDER ALONG THE DRIVEWAY AND EXISTING REAR STAIRS
- SAWCUT EXISTING DRIVEWAY TO REMOVE FOR GRASS

NOTE - ANY DEMOLITION ITEMS LOCATED IN THE CRZ OF EXISTING TREES ARE TO BE REMOVED BY HAND OR HAND MACHINERY IN AREAS OF TREE CRITICAL ROOT ZONES

**NO TREES ARE TO BE REMOVED DURING DEMOLITION.
ITEMS LOCATED IN TREE CRITICAL ROOT ZONE ARE
TO BE REMOVED BY HAND**

PRE-CONSTRUCTION IMPERVIOUS AREA:

EXISTING IMPERVIOUS AREA	SF
EX. HOUSE	2,286
EX. FRONT PORCH	40
EX. DRIVEWAY	2,546
EX. FLUMES	185
EX. FRONT WALKWAY AND STAIRS	139
EX. STONE STEPS	73
EX. PAVERS	36
EX. GARAGE AND OVERHANG	496
EX. GAZEBO	92
EX. STONE PATIO	416
EX. POOL AREA	1,262
EX. POOL	683
EX. STAIRS	105
EX. WALLS	333
TOTAL EXISTING IMPERVIOUS AREA	8,692
LOT COVERAGE %	63.92%

ZONING CONFORMANCE:

SITE ZONING: R-75 DISTRICT
 MINIMUM LOT SIZE: 12,000 SF
 LOT WIDTH:
 85 FEET MIN AT STREET
 85 FEET MIN AT BUILDING LINE
 35 FEET MIN FOR CULDESAC
 FRONT SETBACK:
 40 FEET MIN (THOROUGHFARES)
 40 FEET MIN (ARTERIALS)
 35 FEET MIN (COLLECTOR AND ALL OTHERS)
 25 FEET MIN (ALLEY ACCESS)
 SIDE SETBACK: 7.5 FEET
 REAR SETBACK: 40 FEET
 LOT COVERAGE: SHALL NOT EXCEED 35%
 FLOOR AREA: NO LESS THAN 1600 SQ FEET
 OFF-STREET PARKING: 2 SPACES
 BUILDING HEIGHT: NO MORE THAN 35 FEET
 OPEN SPACE: 20%

**ALL ITEMS TO BE REMOVED LOCATED
WITHIN TREE CRZS OR SPRS ARE TO BE
REMOVED BY HAND OR HAND MACHINERY**

24 HOUR EMERGENCY CONTACT: DAN HANLON 404-425-4325

Prepared By:
**CRESCENT VIEW
 ENGINEERING, LLC:**
 211 Fraiser Street
 Marietta, GA 30060
 678-324-8410
 www.crescentvieweng.com

PREPARED FOR:
RED LEVEL RENOVATIONS
 2025 Tuxedo Ave NE, Atlanta, GA 30307
 404-425-4325
 DHANLON@RED-LEVEL.COM

DEMOLITION PLAN

DATE	SCALE	AS SHOWN	DRAWN	AJ	CH	GH
2025-10-08						

POOL CONSTRUCTION PLANS FOR:
1282 OXFORD ROAD NE
 LAND LOT 54, 18 DISTRICT
 DEKALB COUNTY, GEORGIA

CVE PI # 25-447

SHEET NO.
D-1

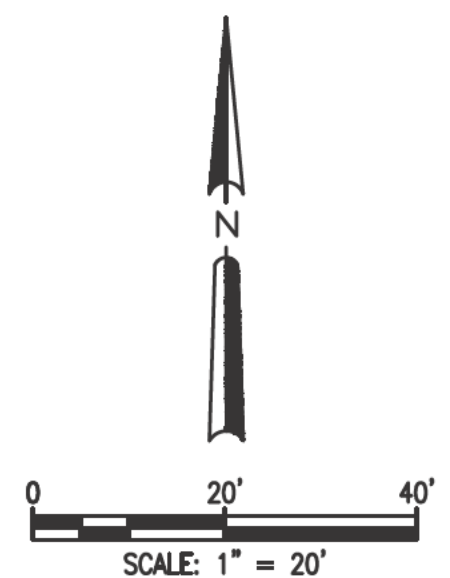
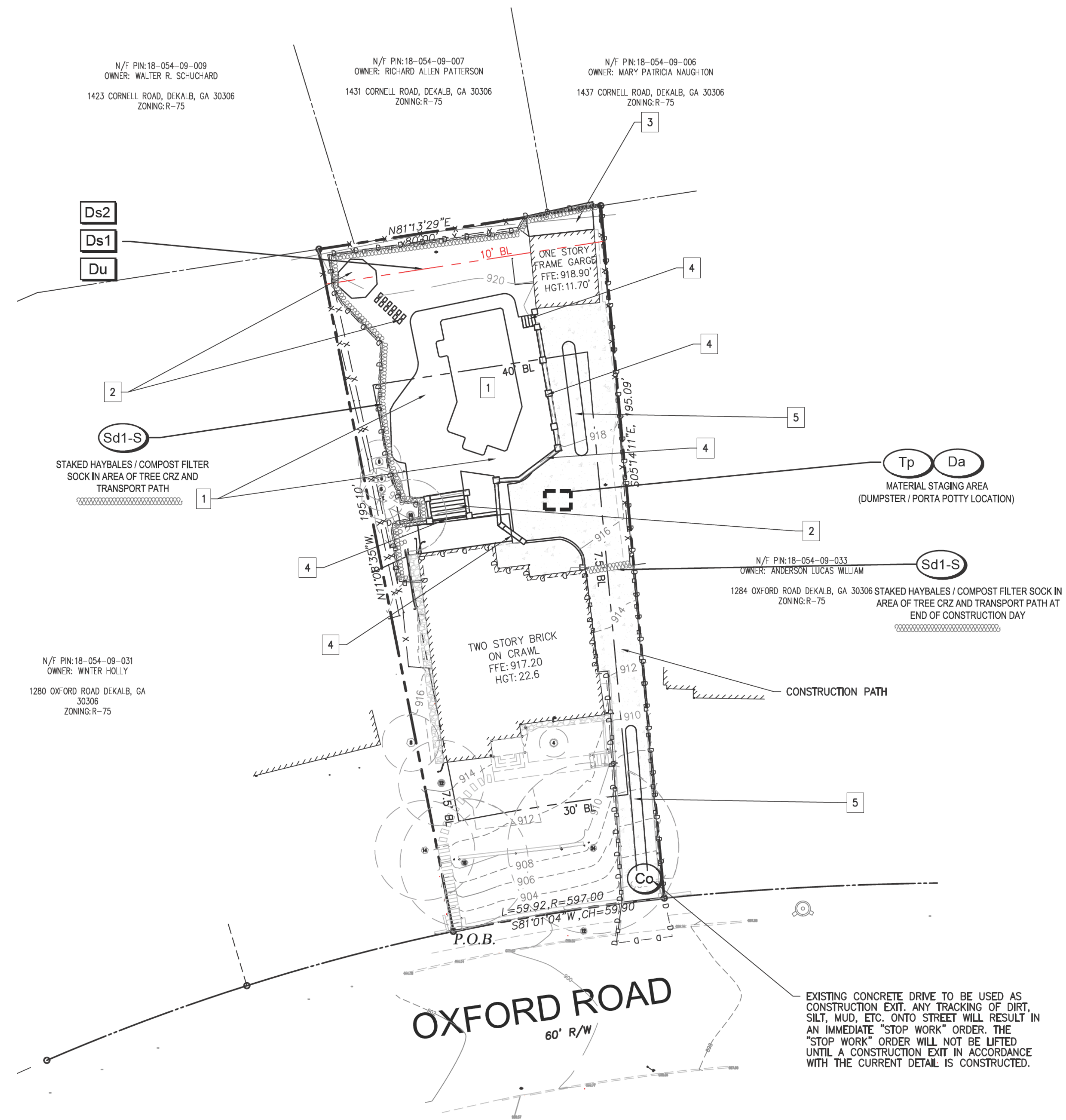

RUNOFF REDUCTION CALCULATIONS			
AREA	SF	NOT/TREATED	BMP LOCATION
EX. HOUSE	2,286	NOT/TREATED	N/A
EX. FRONT PORCH	40	NOT/TREATED	N/A
EX. DRIVEWAY	2,264	NOT/TREATED	N/A
EX. GARAGE	370	NOT/TREATED	N/A
EX. FRONT WALKWAY AND STAIRS	139	NOT/TREATED	N/A
EX. STONE STEPS	73	NOT/TREATED	N/A
EX. PAVERS	23	NOT/TREATED	N/A
EX. STONE PATIO	384	NOT/TREATED	N/A
EX. STAIRS	23	NOT/TREATED	N/A
EX. WALLS	162	NOT/TREATED	N/A
PROPOSED CONCRETE	158	TREATED	TRENCH
PROPOSED REAR LOWER PATIO	202	TREATED	TRENCH
PROPOSED POOL	375	TREATED	TRENCH
PROPOSED POOL AREA + RAMP	1,030	TREATED	TRENCH
PROPOSED POOL COPING	103	TREATED	TRENCH
PROPOSED ACCESSORY STRUCTURE	464	TREATED	TRENCH
PROPOSED WALL / STAIRS	199	TREATED	TRENCH
TOTAL TREATED IMPERVIOUS AREA	2531	SF	
TOTAL IMPERVIOUS AREA	8295	SF	

Runoff Reduction Calculations			
Per GSWMM Section 2.2.4.1			
Runoff Reduction (RRv)			
Site Area (A) =	13,598	SF	
Treated Impervious Area =	2,531	SF	
% impervious (I) =	19.00	%	
$Rv = 0.05 + (I \times 0.009)$	0.221		
$RRv = 1.0 \times Rv \times A / 12$	250.4	CF	

Modified French Drain w/ 6" Pipe Calculation			
Runoff Reduction Calculations	1" required for required area impervious		
Required Treated Impervious Area =	2531.0	SF	
Required RRv Volume =	250.4	CF	
Pipe Volume			
Diameter of Pipe	0.5	FT	
Length of Pipe	68.0	FT	
Volume of Pipe	13.4	CF	
All volume to be provided in Modified French Drain w/ 40% void ratio			
Gravel Volume			
Length of Trench	68.0	FT	
Width of Trench	3.0	FT	
Depth of Trench	3.0	FT	
Volume of Gravel = ((LxWxD) - Pipe Vol) x 0.4 =	239.5	CF	
Gravel Volume + Pipe Volume =	252.8	CF	
Required Volume =	250.4	CF	
Percent of Volume Provided over required	101%		

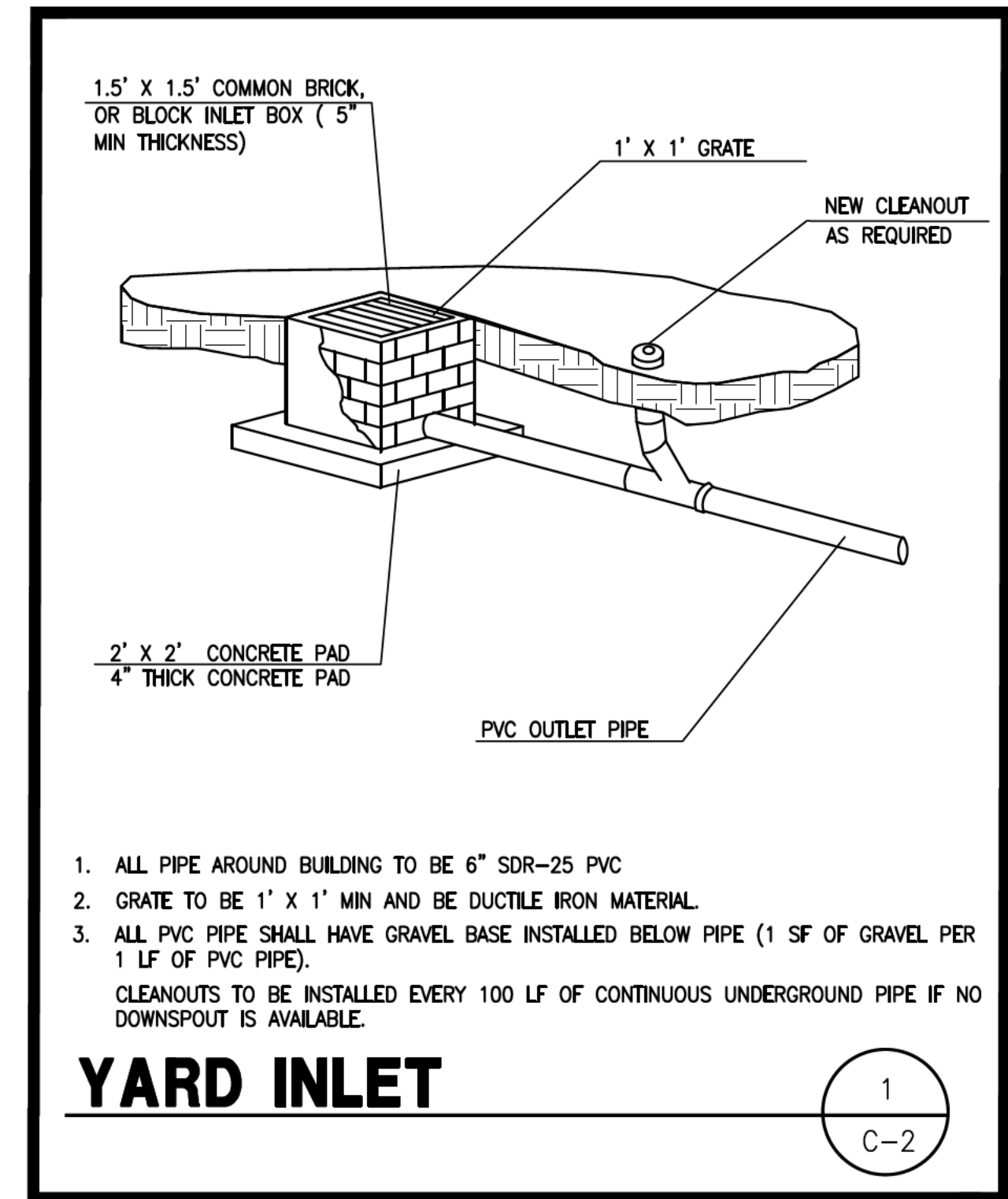

RUNOFF REDUCTION NOTES:

- VEGETATION**
THE MFD IS NORMALLY COVERED WITH TOPSOIL AND MANAGED TURF OR OTHER HERBACEOUS VEGETATION. AS AN ALTERNATIVE, THE AREA ABOVE THE SURFACE OF A MFD MAY BE COVERED WITH PEA GRAVEL (OR LARGER DEPENDING ON THE INFLOW RATES) TO ALLOW FOR INCIDENTAL LATERAL INFLOW ALONG THE EDGE OF GROUND LEVEL IMPERVIOUS SURFACES. THE DOWNSTREAM END OF THE PIPE MUST BE STABILIZED AND CAN BE LANDSCAPED FOR AESTHETICS.
- MAINTENANCE**
- INSPECT GUTTERS AND DOWNSPOUTS REMOVING ACCUMULATED LEAVES AND DEBRIS, CLEANING LEAF REMOVAL SYSTEM(S).
 - IF APPLICABLE, INSPECT PRETREATMENT DEVICES FOR SEDIMENT ACCUMULATION.
 - INSPECT MFD FOLLOWING A LARGE RAINFALL EVENT TO INSURE OVERFLOW IS OPERATING AND FLOW IS NOT CAUSING PROBLEMS.
- CONSTRUCTION STEPS**
- REVIEW POTENTIAL MFD AREAS AND LAYOUT. MFDs SHOULD SLOPE BETWEEN 0.5% AND 6% AWAY FROM THE STRUCTURE AND SHOULD NOT BE LOCATED: (1.) BENEATH AN IMPERVIOUS (PAVED) SURFACE; (2.) ABOVE AN AREA WITH A WATER TABLE OR BEDROCK LESS THAN TWO FEET BELOW THE TRENCH BOTTOM; (3.) OVER OTHER UTILITY LINES; OR (4.) ABOVE A SEPTIC FIELD. INSURE OUTLET DAYLIGHTS AT LEAST TEN FEET FROM PROPERTY LINE.
 - IF SOIL IS A CONCERN PERFORM INFILTRATION TEST. IF THE RATE IS LESS THAN 0.25 IN/HR THIS METHOD CANNOT BE USED. IF THE RATE IS MORE THAN 0.50 IN/HR THE LENGTH OF THE DITCH MAY BE DECREASED 10% FOR EVERY 0.50 IN/HR INFILTRATION RATE INCREASE ABOVE 0.50 IN/HR
 - MEASURE ELEVATIONS AND LAY OUT THE MFD TO THE REQUIRED DIMENSIONS MARKING THE ROUTE AND REQUIRED EXCAVATION DEPTHS. OFTEN A LEVEL LINE (TORPEDO LEVEL) IS USED.
 - PLACE AND TAMP GRAVEL IN DITCH TO PLANNED DEPTH PLACING THE PIPE THREE INCHES DEEP IN THE UPPER PORTION OF THE GRAVEL, THEN PLACE AND GENTLY TAMP GRAVEL UNTIL IT COVERS THE PIPE.
 - PLACE DRAINAGE FABRIC OVER TOP OF PIPE AND STONE.
 - PLACE TOPSOIL AND SOD OR PEA GRAVEL.
 - CUT AND ROUTE DOWNSPOUTS OR OTHER RAINWATER DELIVERY COMPONENTS. ADD STRAP AND SUPPORT AS NEEDED.
 - CREATE A SAFE OVERFLOW AT LEAST 10 FEET FROM YOUR PROPERTY EDGE AND INSURE IT IS PROTECTED FROM EROSION.

RUNOFF REDUCTION DESCRIPTION:

TOTAL PROPOSED IMPERVIOUS AREA FOR THE SITE IS 8,295 SF. THE NEW IMPERVIOUS IS 2,531 SF TO BE TREATED BY RUNOFF REDUCTION IN THE PROPOSED FRENCH DRAIN. SEE LOT COVERAGE CHART FOR DETAILS.

THE MODIFIED FRENCH DRAINS WILL DETAIN FOR A TOTAL OF 2,531 SF OF IMPERVIOUS AREA, AS MENTIONED ABOVE. THE MODIFIED FRENCH DRAINS ARE TO BE FILLED WITH #57 STONE (40% VOID RATIO) AND 3" WIDE AND A TOTAL OF 68' LONG. THE BOTTOM OF THE STORAGE TRENCH IS 3 FEET DEEP. THE RUNOFF REDUCTION VOLUMES PROVIDED BY THE BMP SHOWN EXCEED THE CORRESPONDING STORAGE REQUIREMENTS.

THE RUNOFF REDUCTION VOLUMES PROVIDED BY THE BMP SHOWN EXCEED THE RUNOFF REDUCTION STORAGE REQUIREMENTS. THE MODIFIED FRENCH DRAIN (MFD) WILL PROMOTE GROUNDWATER RECHARGE WHILE RESPECTING THE REQUIRED CRITICAL ROOT ZONE OF SAVE TREES. BECAUSE OF THE LIMITED SPACE, A LONGER TRENCH WAS DESIGNED TO KEEP THE STORAGE FACILITY AS SHALLOW AS POSSIBLE AND PROMOTE MORE DIRECT INFILTRATION.

ANY OVERFLOW DRAINAGE FROM THE SYSTEM WILL FLOW OUT OF THE POP UP DRAIN TOWARDS THE SOUTH PROPERTY LINE.

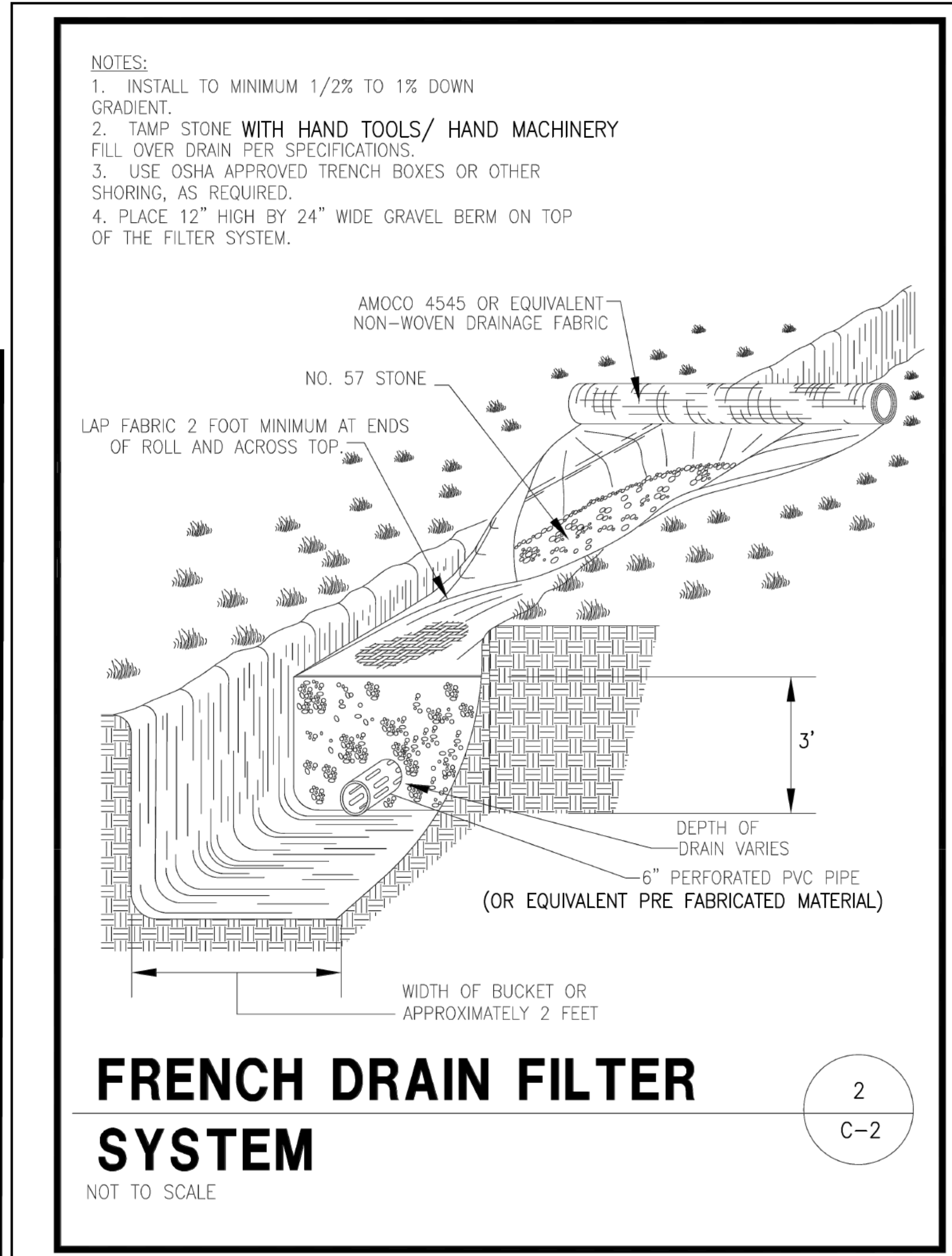

DOWNSPOUT COLLECTOR

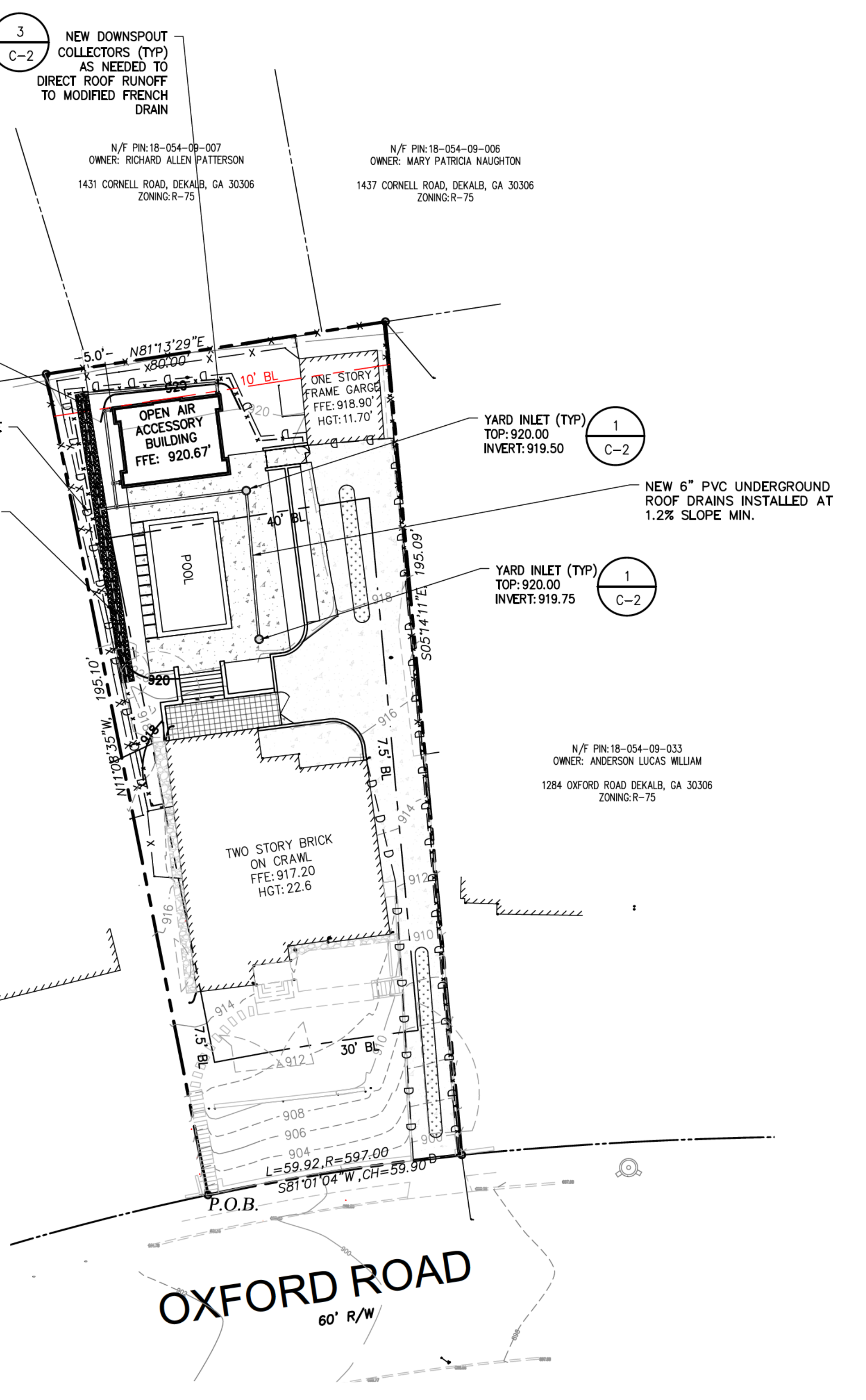
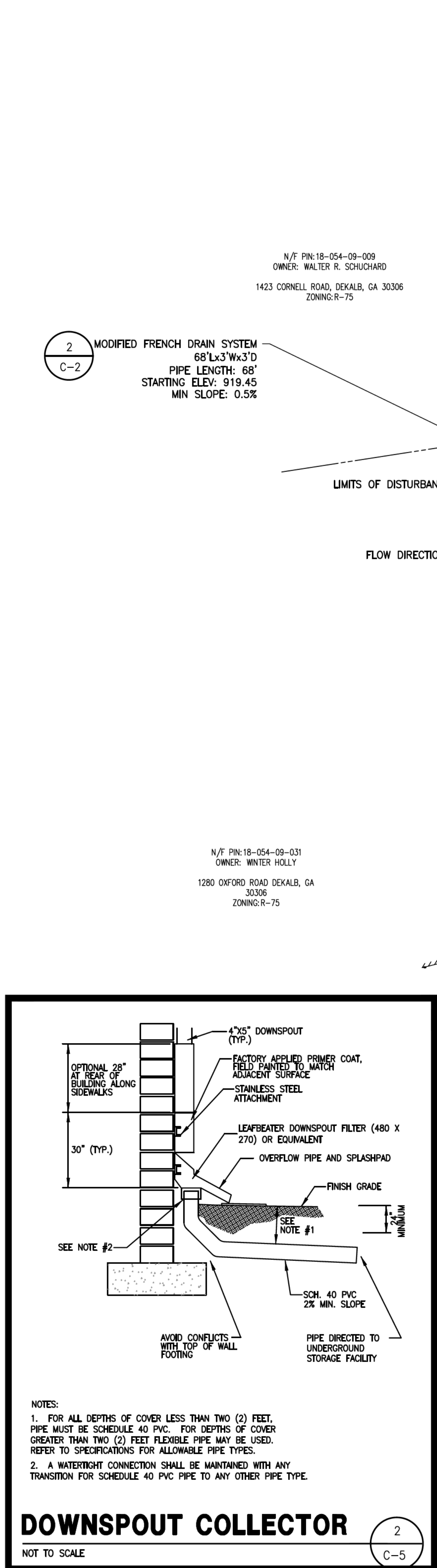

Prepared By:
CRESCENT VIEW ENGINEERING, LLC.
211 Fraiser Street
Marietta, GA 30060
678-504-9410
www.crescentvieweng.com

PREPARED FOR:
RED LEVEL RENOVATIONS
2025 Tuxedo Ave NE, Atlanta, GA 30307
404-425-4325
DHANLON@RED-LEVEL.COM

STORMWATER PLAN

DATE	2025-10-08	REVISIONS
SCALE	AS SHOWN	
DRAWN	AJJ	
CHECKED	GHB	

POOL CONSTRUCTION PLANS FOR:
1282 OXFORD ROAD NE
LAND LOT 54, 18 DISTRICT
DEKALB COUNTY, GEORGIA

CVE P1# 25-447

SHEET NO.
C-2

GEORGIA811
Utilities Protection Center, Inc.
Know what's below. Call before you dig.

SCALE: 1" = 20'



RED LEVEL RENOVATIONS

2025 Tuxedo Avenue
Atlanta, GA 30307

o (404) 425-4325
www.red-level.com

February 5, 2026

Dear Resident,

The homeowner of 1282 Oxford Road NE is seeking a variance to increase the allowance lot coverage from 35% to 61%. The project that is being proposed actually reduces the existing lot coverage, but the variance is required because previous additions to the property increased the lot coverage to 65%. The homeowner attempted to contact you to review the project, but was unable to do so. Plans for the proposed property improvement are enclosed. The Zoning Board of Appeals meeting when the case will be heard will be April 8th at 1pm on Zoom if you would like to attend. Please contact plansustain@dekalbcountyga.gov for additional info.

Best Regards,

Dan Hanlon

[Redacted address information]

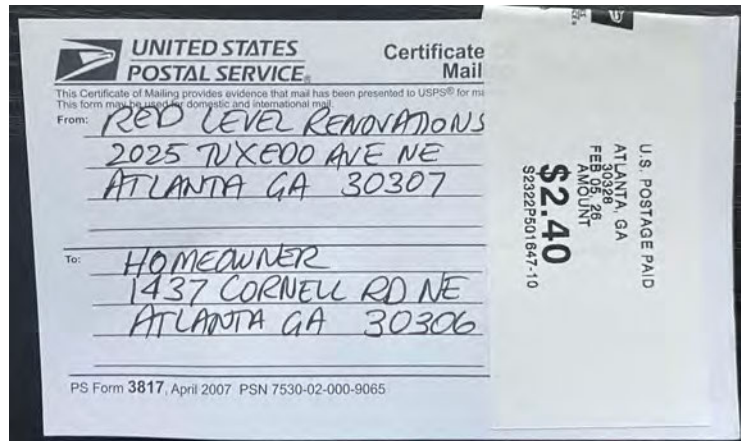







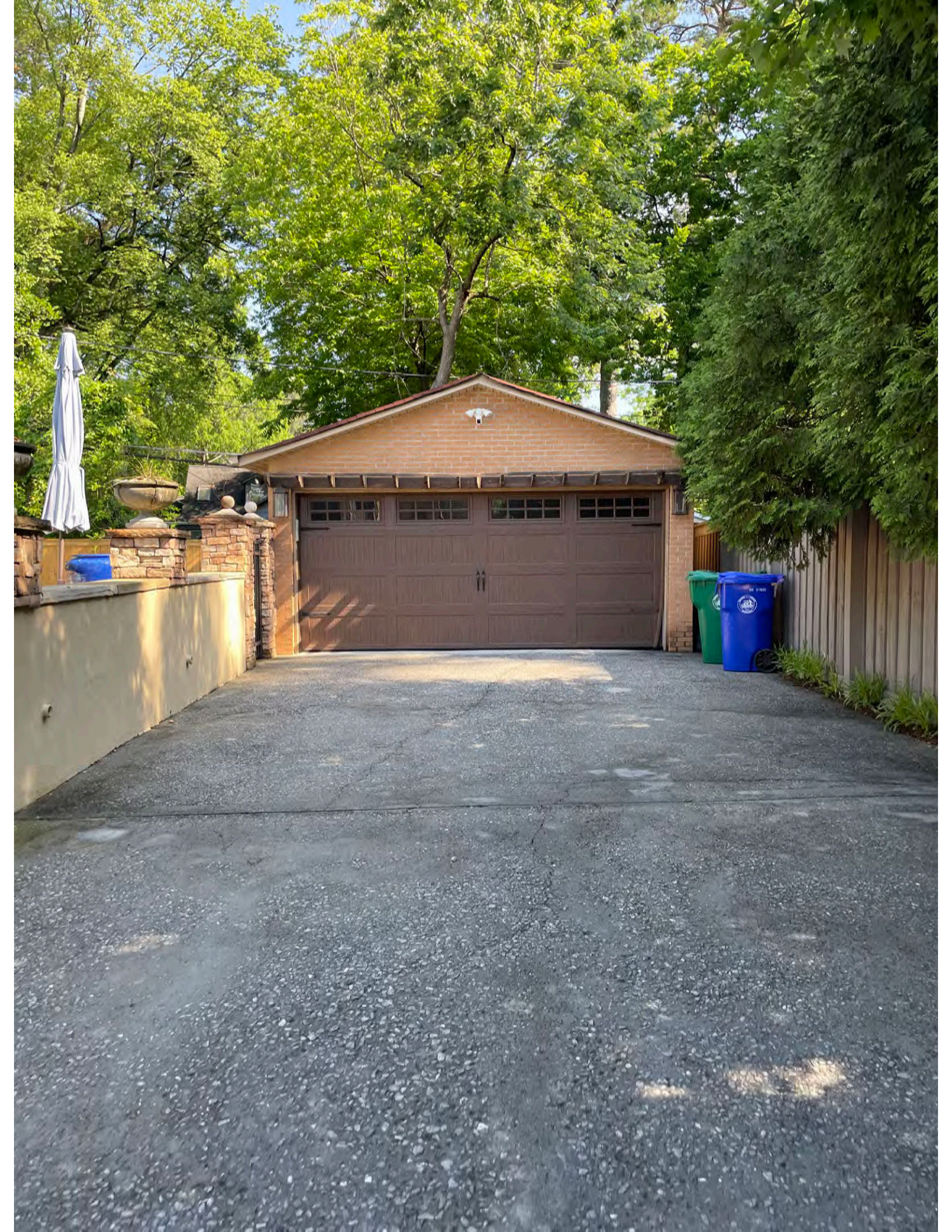







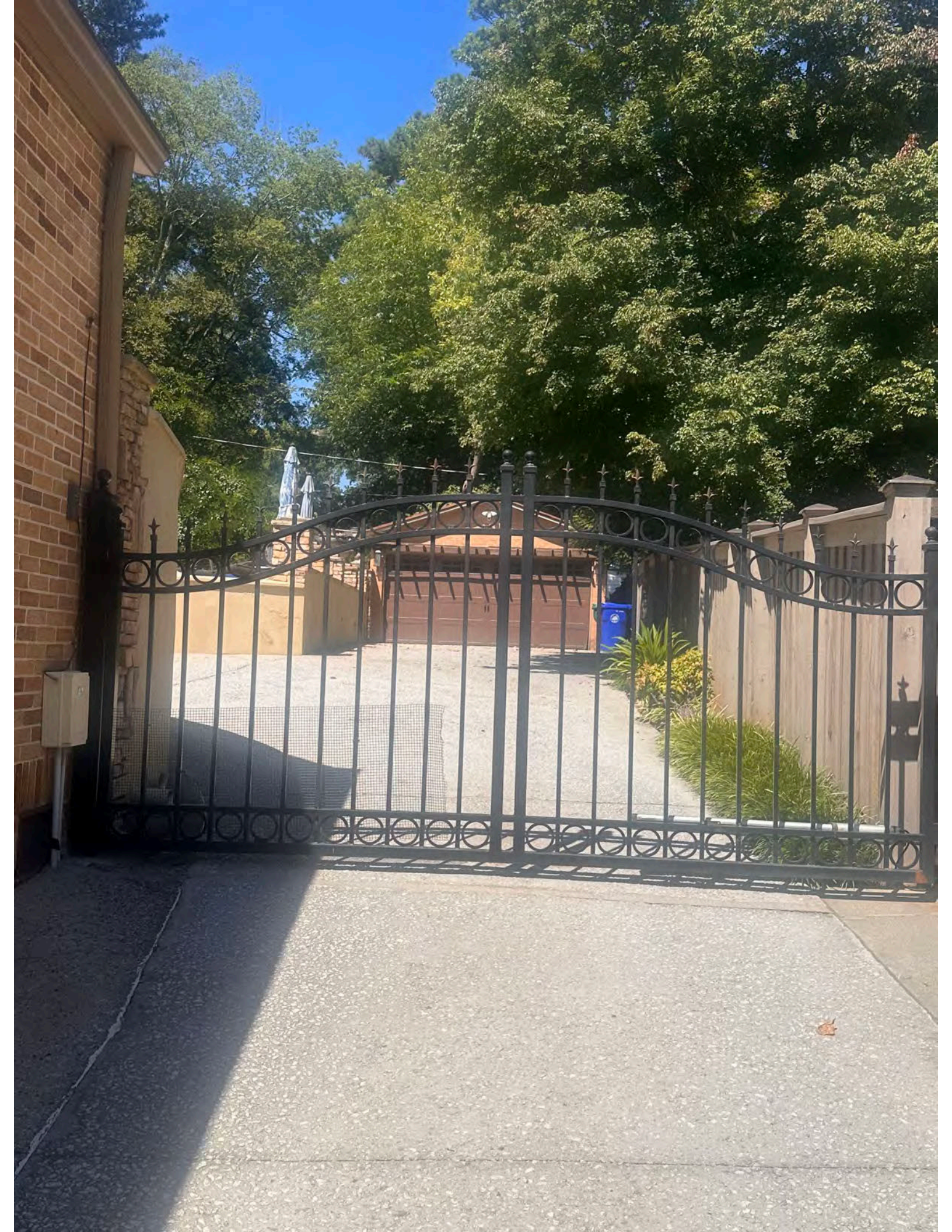

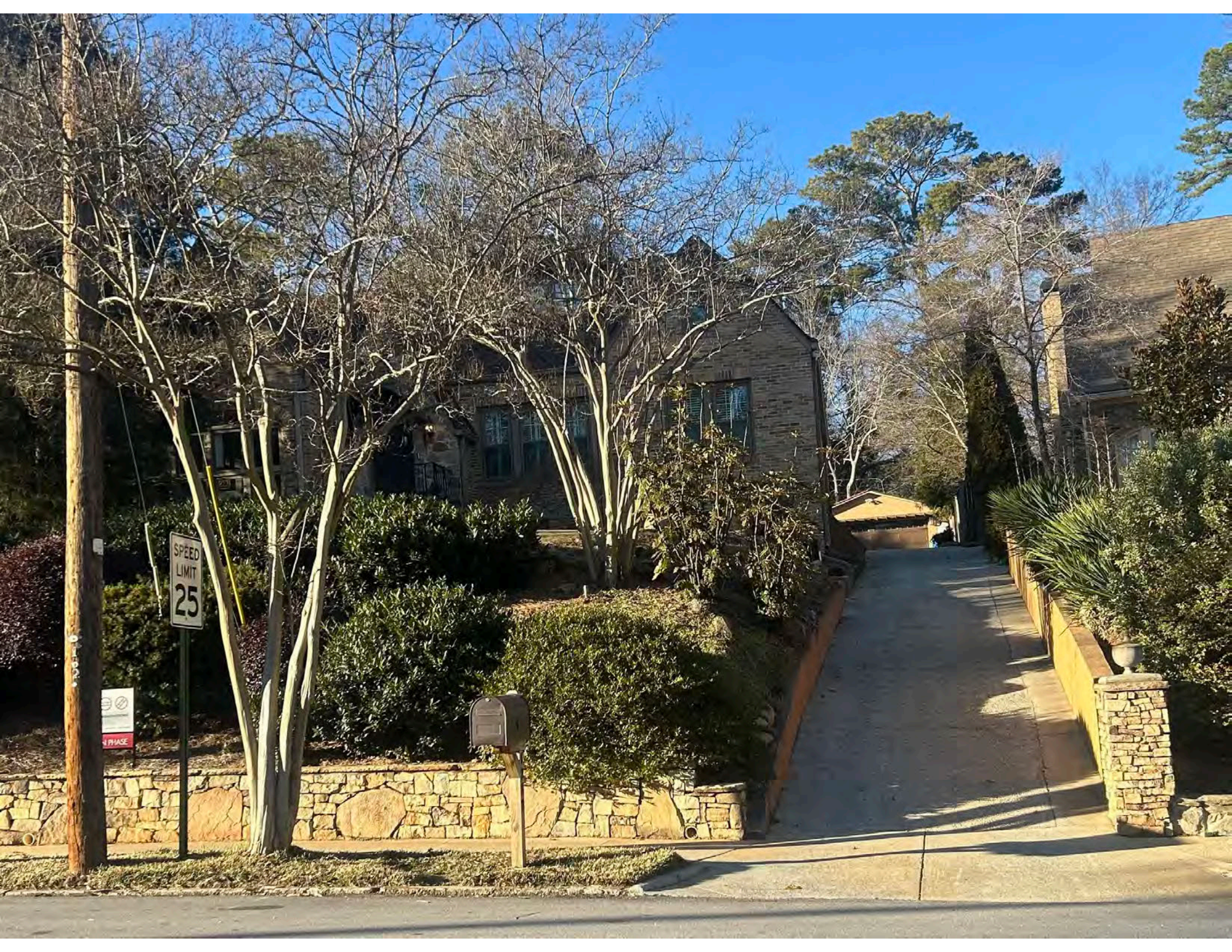

SPEED
LIMIT
25

PHASE