

March 3, 2022

TO: All Bidders under Invitation to Bid No. 21-101447

FROM: Department of Purchasing and Contracting, DeKalb County, Georgia

ADDENDUM NO. 1

Invitation to Bid (ITB) No. 21-101447, 2021 LMIG Road Resurfacing Projects (365 Day Contract) is hereby modified as follows:

1. We have received the following questions pertaining to this ITB. The questions and the responses are below:
 - a. Question: We are assuming that you intend to Patch each road first then overlay it with 1.5in of new final asphalt. This will mean that the road elevations will raise up by the 1.5in thickness. Is this the intent? Or do we need to include costs for removing an additional 1.5in of existing roadway during the patching operations to allow room for the road to be paved back to its current elevations?
Answer: Yes, an overlay of 1.5 inches shall be added. It will not be required to remove an additional 1.5 inches before patching or resurfacing.
 - b. Question: Can you please provide the average expected depth for the patching?
Answer: There is no average depth, but the minimum depth shall be no less than 2 inches.
 - c. Question: Will 19mm be the only mix type used for filling in the patches?
Answer: Yes.
 - d. Question: Just for clarification, the drop inlets and drains are to be adjusted by the contractor, but if any manholes are to be raised after paving, will the county handle that or will the contractor be responsible for those as well under Item No. E (611-8055)?
Answer: The County shall be responsible for the adjustment and/or raising of sewer manholes lids.
 - e. Question: Item No. C (423-5010) Variable Depth Mill quantity is only 25,000 square yards. Can the county please explain where this milling will be required?
Answer: Milling is a case-by-case basis that shall be determined by the project manager or inspector on site.
 - f. Question: If any traffic loops are cut during the milling and patching operation, will the county re-install them?

Answer: Yes, the County shall re-install traffic loops accordingly, however, the contractors must inform the County in a timely manner when loops are damaged and repairs/replacements are required.

- g. Question: When is the expected date of the Notice to Proceed for this contract?

Answer: The Notice to Proceed Date is TBD. We anticipate that award could take up to 120 days from the date the bids are received.

- h. Question: On Candler Pkwy are parking spaces included in the resurfacing and striping? Will we be responsible for replacing speedhumps?

Answer: Yes, parking spaces are included in the resurfacing project. No, the contractor shall not be responsible for replacing speedhumps. This activity shall be performed by the County. Note: The contractor shall remove speed humps as this activity is part of and is included in the contract documents.

- i. Question: Would the County consider utilizing the GDOT Asphalt Cement Index for this project since the time between the bid submission and the overall completion of the project is likely to be 18 Months out? If this were a GDOT Project it would be indexed by GDOT Specs.

Answer: No.

- j. Question: Will the County allow the Contractor to work nights on the high traffic volume roads? Or do we need to plan to pave all of the roads during the daytime hours called out on page 104 of 118 Paragraph F?

Answer: Regarding work at nights, the contractor shall adhere to the County Ordinance (Section 23-2) pertaining to roads with restricted work hours.

- k. Question: According to Google Earth it looks like Lehigh Blvd (Radcliffe Blvd-Flakes Mill Rd) may have already been recently paved. Do you want to do it again?

Answer: Yes, we will patch and resurface this road.

- l. Question: Could you please identify what all of the Column Headers within the Quantities Sheet stand for. While we understand most of them, some are a mystery to us.

Answer: The only abbreviations on the spreadsheet that pertain to the contract bids have been specified below.

- LIDS (LID is lid, as in top/cover, it is referring to the lid/top/cover of a manhole)
- PD (Patching Depth)
- RD (Resurfacing Depth)

- m. Question: Since we don't always know where Traffic Signal Loop are at would the County consider adding a bid item for Traffic Signal Loops – Per Each should some need to be replaced? This is the fairest way to pay for this and to keep the County from overpaying for something that may or may not be required.

Answer: No, the County shall replace/repair all damaged loops.

- n. Question: Which Roads do you intend to Mill, the Quantities sheet provide shows that none of the roads get milled?

Answer: Milling is case-by-case and will be determined by the Project Manager or Construction Inspector on site.

- o. Question: What is going to be the Required Depth for the Milling?

Answer: Milling depth varies and shall be determined by the Project Manager and or Construction Inspector.

- p. Question: Will All Roads get Milled? If not please provide a criteria for when and if Milling will be required. (Edge Milling, Full Width Milling, Spot Milling etc.

Answer: No, not all roads are required to be milled. Roads that are milled will either be edge milled or profile milled (full width).

- q. Question: Will the Contractor be allowed to use Portable Advanced Warning Sign for this work or will the County expect the Contractor to install Post Mounted Advanced Warning Signs on all of the Roads?

Answer: Yes, portable signs can be used.

- r. Question: Will the County provide Police for Traffic Control Flagging for this project? If not then could you please identify which roads you want the Contractor to use Police on for Traffic Control? The fairest way to handle this would be to create a bid item for Police Flagging – Per Hour.

Answer: The contractor shall be responsible for all traffic control and flagging operations. There is a line item listed for this activity in the contract document. Traffic Control shall be performed in accordance with the MUTCD Manual. Officers will only be required to flag intersections where traffic lights exist.

- s. Question: Within Exhibit II, page 109 of 118 Paragraph H says that streets milled for patching shall be paved the same day, we assume that you are referring to paving back with the Patching Mix and not the final surface mix?

Answer: No, we are referring to roads that require edge milling or profile milling before resurfacing.

- t. Question: Within Exhibit II, page 109 of 118 Paragraph K refers to paving back the patching areas. It says that 9.5mm or 19.0mm shall be used. There is a tremendous price difference between these two mixes and structurally the 9.5mm will make a poor quality patching mix. Would you please identify the roads that you anticipated will get patched with 9.5mm so we can properly price out the Patching bid item? Keep in mind that 9.5mm Patching is very likely to fail in a much shorter time frame.

Answer: All roads shall be patched with 19MM.

u. Question: What will be the paving depth for each road for the final surface 9.5mm Type II paving?

Answer: 1.5 inches.

v. Question: Within Exhibit II, page 116 of 118 Paragraph VIII refers to Patching, Milling, Resurfacing and Technical Drawings Specifications. We did not find the Typical Section Drawings (DS-1, DS-2, DS-3, DS-4) that are referenced in this paragraph, can you please provide them?

Answer: The Drawings are included in the Addendum.

w. Question: On Past projects like this Dekalb Co has taken several months to award and execute contracts. With the volatility of the Asphalt Cement Market right now, could you please provide an Anticipated Notice to Proceed Date for this contract so that we can account for the potential increasing cost for the Asphalt Materials?

Answer: The Notice to Proceed Date is TBD. We anticipate that award could take up to 120 days from the date the bids are received.

2. It is the responsibility of each bidder to ensure that he is aware of all addenda issued under this ITB. Please sign and return this addendum. You may email Angel Frazier at amfrazier@dekalbcountyga.gov before the bids are due to confirm the number of addenda issued.
3. All other conditions remain in full force and effect.

Angel Frazier

 Angel Frazier
 Procurement Agent
 Department of Purchasing and Contracting

ACKNOWLEDGEMENT

Date _____

The above Addendum is hereby acknowledged:

(Name of Bidder)

(Signature)

(Title)

CC/AF

CC

CC

TYPICAL MILLING SECTION

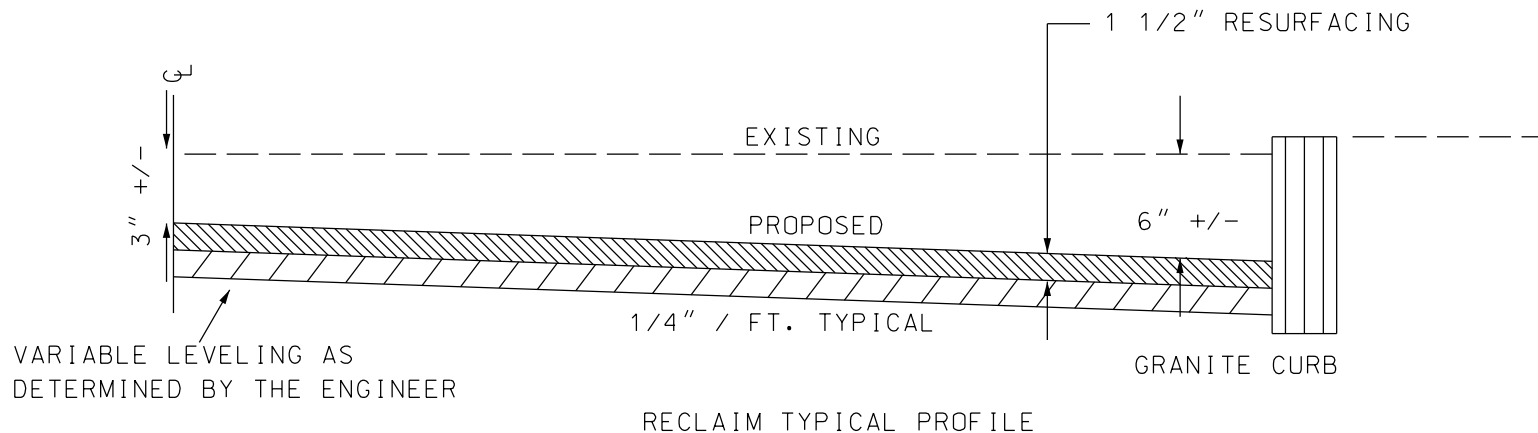
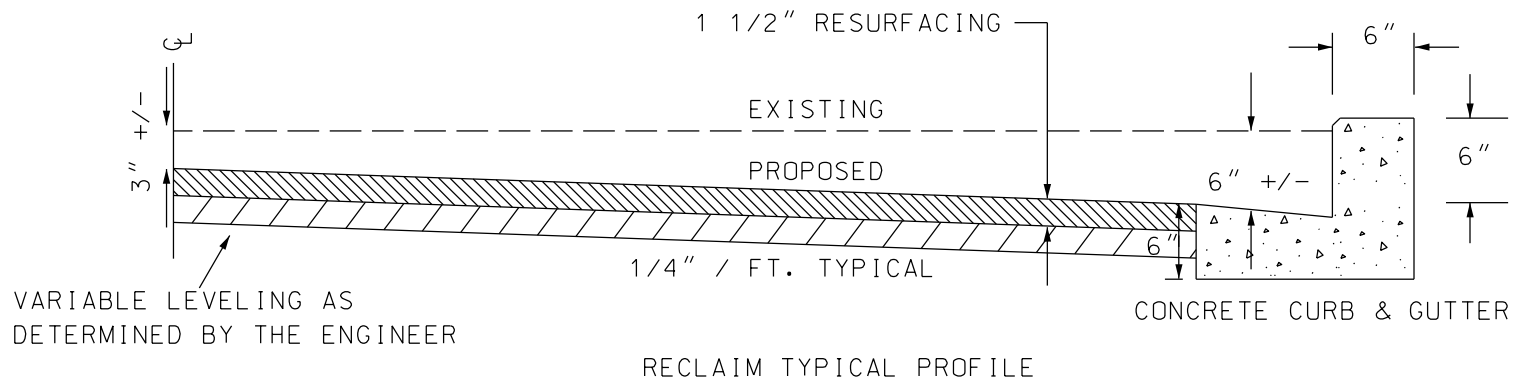

NOTE: THE MILLING DEPTHS ARE SHOWN ON THE SUMMARY OF QUANTITIES OR WILL BE DETERMINED BY THE ENGINEER

DS-1

		DEPT OF ROADS & DRAINAGE AND DEVELOPMENT DEKALB COUNTY, GEORGIA CONSTRUCTION & DESIGN STANDARDS	
		TYPICAL LEVELING SECTION DWG. NO.	SHEET OF
DRAWN BY CHECKED BY SCALE (NONE)		APPD.	DATE
		DIRECTOR	

TYPICAL PATCHING SECTION

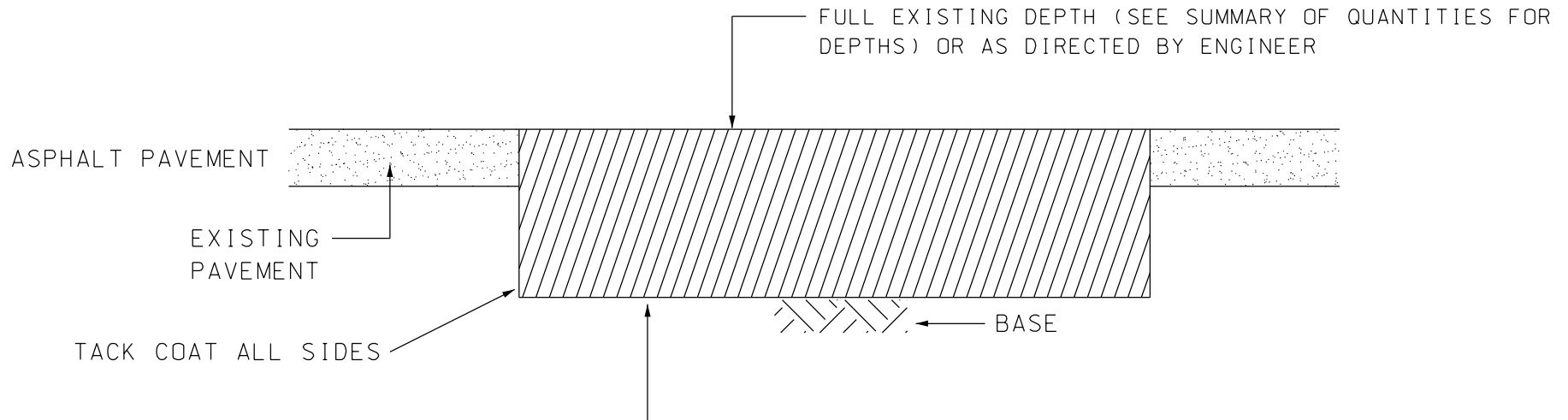

PATCHING SHALL BE ACHIEVED WITH "F" MIX (9.5mm) OR BINDER (19mm) IN COMPACTED 2" LIFTS AS DIRECTED BY ENGINEER ALL PATCHES SHALL BE A MINIMUM TWO INCHES IN DEPTH PATCH OUT PAVEMENT AREAS MARKED OUT BY THE ENGINEER

DS-2

		DEPT OF ROADS & DRAINAGE AND DEVELOPMENT DEKALB COUNTY, GEORGIA CONSTRUCTION & DESIGN STANDARDS	
		TYPICAL PATCHING SECTION DWG NO. SHEET OF	
DRAWN BY	CHECKED BY	SCALE (NONE)	APPD. DATE
			_____ DIRECTOR

TYPICAL RESURFACING SECTION

CURB AND GUTTER DETAIL
DETAIL FOR FEATHERING SURFACING

CURB AND GUTTER

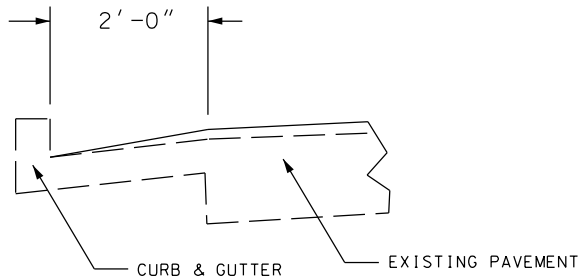

HEADER CURB

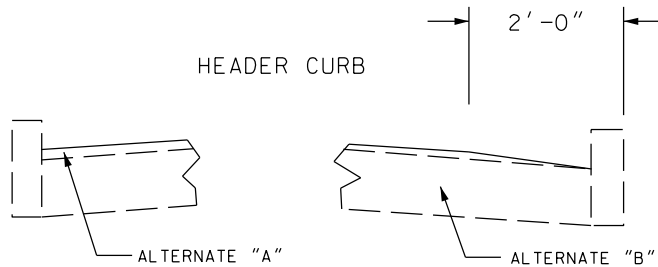

NOTE: METHOD OF FEATHERING OF PAVEMENT EDGE. (ALTERNATE A OR ALTERNATE B) SHALL BE DETERMINED BY THE ENGINEER. UNDER NORMAL CONDITIONS ALTERNATE A SHALL BE USED FOR FEATHERING UNLESS RESURFACING HAS REDUCED THE "EFFECTIVE HEIGHT" OF THE EXISTING CURB. IN THIS EVENT ALTERNATE B SHALL BE USED.

NOTE: THE DIFFERENCE BETWEEN THE NEW RIDING SURFACE AND THE FEATHERING IN THE CURB AND GUTTER SHALL NOT EXCEED 0.25" PER FT.

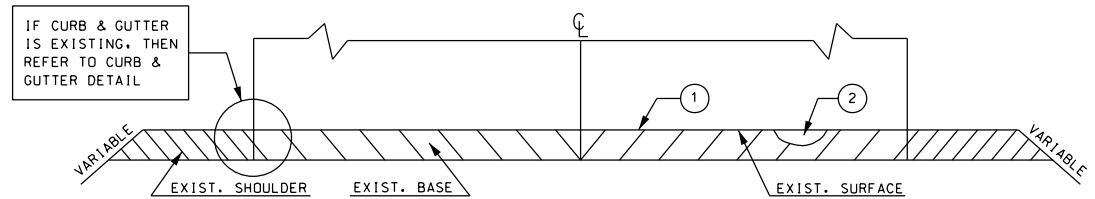

NO SCALE

REQ'D ① 165 LBS PER SQ. YD. ASPH. CONC. "F" MIX (9.5mm) or "E" MIX (12.5mm) SUPERPAVE, TYPE II, BLEND 1, INCL. BITUMIN & H LIME, AS DIRECTED BY ENGINEER

REQ'D ② ASPHALTIC CONCRETE LEVELING TO BE PLACED AS DIRECTED BY ENGINEER.

NOTE: THE LOCAL GOVERNMENT WILL CERTIFY ALL NECESSARY R/W REMOVE OR ADJUST ALL UTILITIES AND DO THE NECESSARY PATCHING AS DIRECTED BY THE ENGINEER
NOTE: AT NO COST TO THE DEPARTMENT OF TRANSPORTATION.

NOTE: SAND ASPHALT WILL NOT BE ALLOWED FOR LEVELING.

PAVING OF TURNOUTS AND SIDEROADS AND DRIVES WILL BE A MINIMUM OF 3 FEET ADDITIONAL WIDTH MAY BE NECESSARY TO PROVIDE A SMOOTH, SAFE AND WELL DEFINED TRANSITION TO AND FROM PUBLIC ROADS AND DRIVEWAYS.

THIS TYPICAL SECTION APPLIES TO

DS-3

		DEPT OF ROADS & DRAINAGE AND DEVELOPMENT DEKALB COUNTY, GEORGIA CONSTRUCTION & DESIGN STANDARDS	
		TYPICAL RESURFACING SECTION DWG NO. SHEET OF	
DRAWN BY CHECKED BY SCALE (NONE)		APPD. DATE DIRECTOR	

TYPICAL MANHOLE ADJUSTMENT DIAGRAM SECTION

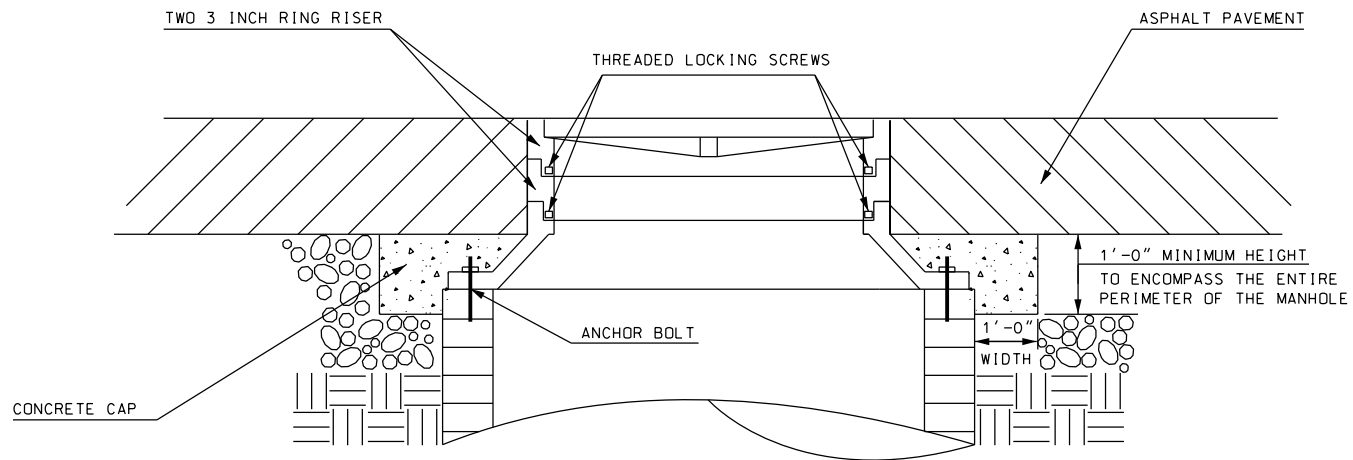

CASE IV: DIAGRAM OF "APPROVED MANHOLE METHOD"
 REQUIRE FOR ANY NEW INSTALLATION OR WHEN EXISTING
 MANHOLES MUST BE LOWERED & RAISED

DETAIL DS-4
 NOT TOSCALE

DS-4

		DEPT OF ROADS & DRAINAGE AND DEVELOPMENT DEKALB COUNTY, GEORGIA CONSTRUCTION & DESIGN STANDARDS	
		TYPICAL MANHOLE DWG NO. SHEET OF	
DRAWN BY CHECKED BY SCALE (NONE)		APPD. DATE DIRECTOR	

Signature: *Crystal Creekmore*

Email: ccreekmore@dekalbcountyga.gov





Addendum No. 1 ITB No. 21-101447

Final Audit Report

2022-03-03

Created:	2022-03-03
By:	Angel Frazier (amfrazier@dekalbcountyga.gov)
Status:	Signed
Transaction ID:	CBJCHBCAABAAjVlp5Wyl36meeHRfZ1_nppAxX2ob2EBZ

"Addendum No. 1 ITB No. 21-101447" History

-  Document created by Angel Frazier (amfrazier@dekalbcountyga.gov)
2022-03-03 - 7:07:02 PM GMT- IP address: 204.120.180.4
-  Document emailed to Crystal Creekmore (ccreekmore@dekalbcountyga.gov) for signature
2022-03-03 - 7:07:33 PM GMT
-  Email viewed by Crystal Creekmore (ccreekmore@dekalbcountyga.gov)
2022-03-03 - 7:09:50 PM GMT- IP address: 104.47.64.254
-  Document e-signed by Crystal Creekmore (ccreekmore@dekalbcountyga.gov)
Signature Date: 2022-03-03 - 7:11:02 PM GMT - Time Source: server- IP address: 204.120.180.4
-  Agreement completed.
2022-03-03 - 7:11:02 PM GMT