



DeKalb County
GEORGIA

DeKalb County
Department of Purchasing and Contracting
Maloof Administration Building, 1300 Commerce Drive, 2nd Floor,
Decatur, Georgia 30030

August 12, 2019

INVITATION TO BID (ITB) NO. 19-101137
FOR
FENCE INSTALLATION AND REPAIRS
(ANNUAL CONTRACT WITH 2 OPTIONS TO RENEW) –

DEKALB COUNTY, GEORGIA

Procurement Agent: L. Deneen Walters
Phone: 404-687-3558
Email: Ldwalters@dekalbcountyga.gov

Mandatory DeKalb First LSBE Meeting: **August 14, 2019 & August 21, 2019**
4572 Memorial Drive, Decatur, Georgia 30032
(Bidders must attend 1 meeting on either of the dates listed in person or via video conference.) Main Conference Room - A

(Meetings are held at 10:00 a.m. and 2:00 p.m.)
Video Conference: Utilize the link supplied on our webpage labeled "DeKalb First LSBE Video Meeting"

Pre-Bid Conference and Site Visit: No Pre-Bid Conference and Site Visit is Required
Deadline for Submission of Questions: 5:00 P.M. ET, August 23, 2019
Bid Opening: 3:00 P.M. ET, September 5, 2019
Price Schedule Opening: 3 – 5 Business days after Bid Opening

FIRM'S NAME AND ADDRESS: (Street, City, State and Zip Code. Type or print): Federal Tax ID No. _____ ARE YOU A DEKALB COUNTY FIRM? Yes ___ No ___	TELEPHONE AND FAX NUMBERS WITH AREA CODE: Phone: _____ Fax: _____ E-mail: _____
SIGNATURE OF PERSON AUTHORIZED TO SIGN BID AND DATE: _____	SIGNER'S NAME AND TITLE (Type of Print): _____

THE RESPONSIBILITY FOR SUBMITTING A RESPONSE TO THIS BID TO THE DEPARTMENT OF PURCHASING AND CONTRACTING OF DEKALB COUNTY GOVERNMENT ON OR BEFORE THE STATED DATE AND TIME WILL BE SOLELY AND STRICTLY THE RESPONSIBILITY OF THE BIDDER.

TABLE OF CONTENTS

FOR

INVITATION TO BID NO. ITB No. 19-101137

INVITATION TO BID OVERVIEW3

INVITATION TO BID PROCEDURES5

GENERAL TERMS AND CONDITIONS10

MINIMUM SPECIFICATIONS 23-45

PRICE SCHEDULE 46-65

BID ACKNOWLEDGEMENT FORM66

ATTACHMENT A.....67

ATTACHMENT B.....68

ATTACHMENT C.....69

ATTACHMENT E.....71

ATTACHMENT F.....72

ATTACHMENT G.....73

ATTACHMENT H.....86-104

INVITATION TO BID OVERVIEW

A. PURPOSE:

DeKalb County Government (the County) is soliciting bids for **ITB No. 19-101137 and Fence Installation and Repairs (Annual Contract with 2 Options to Renew)** from responsible bidders.

B. GENERAL INFORMATION:

1. BID TIMETABLE:

The anticipated schedule for the bid process is as follows:

Date Issued:	August 12, 2019
Mandatory DeKalb First LSBE Meeting: (Bidders must attend 1 meeting on either of the dates listed.)	August 14, 2019 & August 21, 2019 4572 Memorial Drive, Decatur, Georgia 30032 Main Conference Room - A (Meetings are held at 10:00 a.m. and 2:00 p.m.)
Pre-Bid Conference and Site Visit:	No Pre-Bid Conference and Site Visit Required for this Solicitation
Deadline for Submission of Questions:	5:00 P.M. ET, August 23, 2019
Bid Opening:	<u>3:00 P.M. ET, September 5, 2019</u>
Price Schedule Opening:	3 – 5 Business days after Bid Opening
Bids Valid Until:	Bids shall be valid for 90 days from and including the bid opening date.

Sealed bids are to be addressed and delivered to:

DeKalb County Department of Purchasing and Contracting
Maloof Administration Building
1300 Commerce Drive, 2nd Floor
Decatur, Georgia 30030, not later than **3:00 P.M. ET, September 5, 2019.**

*****PRICE SCHEDULE MUST BE SUBMITTED IN A SEPARATE SEALED ENVELOPE OR BIDDER WILL BE DEEMED NON-RESPONSIVE AND WILL NOT BE CONSIDERED FOR AWARD*****

Submit **one original bid package** (inclusive of the entire Invitation to Bid document and required documents with the exception of the price schedule) stamped "Original" and **two sealed identical copies** stamped "Copy" of the bid package to the address listed above.

2. CONTACT PERSON:

The contact person for this bid is **L. Deneen Walters, Procurement Agent**. General inquiries concerning the meaning or interpretation of this Invitation to Bid (ITB) may be requested from the contact person via telephone at 404-687-3558 or via email at ldwalters@dekalbcountyga.gov. Questions and requests for information or clarification concerning the specifications in this ITB must be submitted to the above listed contact person via email no later than the date and time listed in the bid timetable. Questions and

requests received after the above stated time or sent to anyone other than the listed contact person will not receive a response or be the subject of addenda.

3. **QUESTIONS:**

All requests must be in writing. Any explanation desired by a bidder regarding the meaning or interpretation of the Invitation to Bid, drawings, specifications, requirements, etc., **must be requested in writing** and with sufficient time allowed for a reply to reach bidders before the submission of their bids. If any statement in the bidding documents, specifications, plans, etc., appear ambiguous to the Bidder, Bidder is specifically instructed to make a written request to the Department of Purchasing and Contracting as outlined *in* the preceding sentence. Any information given to a prospective bidder concerning an Invitation to Bid **will** be furnished to all prospective bidders, as an addenda to the Invitation, if such information is necessary to bidders in submitting bids on the Invitation or if the lack of such information would be prejudicial to uninformed bidders. Oral explanations or instructions given before the award of the contract will not be binding. **Questions must be submitted no later than 5:00 pm EST on “August 23, 2019.”**

4. **ADDITIONAL INFORMATION/ADDENDA:**

The County will issue responses to inquiries and any other corrections or amendments it deems necessary in written addenda issued prior to the bid opening date. Bidders should not rely on any representations, statements or explanations other than those made in this ITB or in any addendum to this ITB. Where there appears to be a conflict between the ITB and any addenda issued, the last addendum issued will prevail. It is the responsibility of the Bidder to ensure awareness of all addenda issued for this solicitation. Please acknowledge the addenda and submit to the DeKalb County Department of Purchasing and Contracting as requested. Bidders may contact the above listed contact person to verify the number of addenda prior to submission. Addenda issued for this ITB will be posted on DeKalb County's website, www.dekalbcountyga.gov/formalbids. Bidder should regularly check the County's website for addenda.

INVITATION TO BID PROCEDURES

BIDDER INFORMATION:

1. **FAILURE TO SUBMIT THE PRICE SCHEDULE IN A SEPARATE SEALED ENVELOPE SHALL DEEM THE BID NON-RESPONSIVE. INCLUDING THE PRICE SCHEDULE IN ANY AREA OUTSIDE OF ITS SEPARATE, SEALED ENVELOPE WILL RESULT IN BIDDER'S BID BEING DEEMED NON-RESPONSIVE.**
2. Failure to return all pages of this Invitation to Bid may result in bid being deemed non-responsive.
3. Minimum specifications are intended to be open and non-restrictive. Contractors are invited to inform the DeKalb County Department of Purchasing and Contracting whenever specifications or procedures appear not to be fair and open. Such information should be supplied as early in the procurement process as possible. Information received in less than five (5) days prior to the scheduled bid opening will not be acted upon unless the DeKalb County Department of Purchasing and Contracting rules that it is in the best interest of the County to consider.
4. Brand names and numbers when provided in solicitations are for reference and to establish a quality standard. Any reference to a brand name shall not be construed as restricting Bidders to that manufacturer (unless "no substitutes" is stated). Bids on equal items will be considered, provided the bid clearly describes the article offered and it is equal or better in quality and function and fully compatible with this requirement.
5. By submitting a bid, Bidder warrants that any goods or services supplied to DeKalb County Government meet or exceed the specifications set forth in this solicitation.
6. If any supplies, materials, and equipment are provided to the County under this solicitation, then such items shall be new and in first-class condition unless the solicitation specifically allows offers of used, reconditioned, or remanufactured items. If newly manufactured products are specified, such products shall be of recent origin and not previously used. No equipment of any type is acceptable if serial numbers or any other manufacturer's identification labels or marks have been removed, obliterated, or changed in any way. A Contractor delivering any such equipment to the County will be deemed to have breached the contract and appropriate action will be taken by the DeKalb County Government Purchasing and Contracting Department.
7. Time of delivery is a part of the solicitation and an element of the contract that is to be awarded. If the Bidder cannot meet the required service delivery dates, a bid should not be submitted. Failure to deliver in accordance with the contract could result in the Contractor being declared in default.

8. Bid Withdrawal

Bids may be withdrawn at any time prior to the bid opening. After bids have been publicly opened, withdrawal of bids shall be based upon Part 3, Section IV, F. within the DeKalb County Purchasing Policy.

9. Expenses of Preparing Responses to this ITB

The County accepts no responsibility for any expenses incurred by Bidders who submit bids in response to this ITB. Such expenses are to be borne exclusively by the Bidders.

10. It is the responsibility of each Bidder to ensure that its submission is received by 3:00 p.m. on the bid due date. The time/date stamp clock located in the Department of Purchasing & Contracting shall serve as the official authority to determine lateness of any bid. The bid opening time shall be strictly observed. Be aware that visitors to our offices will go through a security screening process upon entering the building. Bidders should plan enough time to ensure that they will be able to deliver their submission prior to our deadline. Late submissions, for whatever reason, will not be evaluated. Bidders should plan their deliveries accordingly. Telephone or fax bids will not be accepted.

11. Price Schedule openings shall be conducted in the Department of Purchasing and Contracting three (3) to five (5) days after the bid opening. Only the Price Schedules of responsive bidders shall be opened. The County reserves the right to decide which bid(s) will be deemed responsive and said determination shall be made in accordance with the requirements stated in this solicitation.

12. Federal Work Authorization

Pursuant to O.C.G.A. §13-10-91, the County cannot enter into a contract for the physical performance of services unless the Contractor, its Subcontractor(s) and sub-subcontractor(s), as that term is defined by state law, register and participate in the Federal Work Authorization Program to verify specific information on all new employees. The Bidder certifies that he/she has complied and will continue to comply throughout the contract term with O.C.G.A. §13-10-91 and any related and applicable Georgia Department of Labor Rule. Contractor agrees that in the event it employs or contracts with any Subcontractor(s) in connection with this contract, Contractor will secure from each Subcontractor an affidavit that certifies the Subcontractor's current and continuing compliance with O.C.G.A. §13-10-91 throughout the contract term. Each Subcontractor agrees that in the event it employs or contracts with any sub-subcontractor(s), each Subcontractor will secure from each sub-subcontractor an affidavit that certifies the sub-subcontractor's current and continuing compliance with O.C.G.A. §13-10-91 throughout the contract term.

13. LSBE Information

a. It is the objective of the Chief Executive Officer and Board of Commissioners of DeKalb County to provide maximum practicable opportunity for all businesses to participate in the performance of government contracts. The current DeKalb County List of Certified Vendors

may be found on the County website at <http://www.dekalbcountyga.gov/purchasing/pdf/supplierList.pdf>

- b. It is required that all responding Bidders attend the mandatory LSBE meeting within two-weeks of the solicitation's advertisement, and comply, complete and submit all LSBE forms with the Bidder's response in order to remain responsive. Attendance can be in person, via video conference and teleconference. Video conferencing is available through Skype/Lync. Instructions for attendance via video conference can be found on the County's website at <https://www.dekalbcountyga.gov/purchasing-contracting/dekalb-first-lsbe-program>.
- c. For further details regarding the DeKalb First Local Small Business Enterprise Ordinance, contact the LSBE Program representative, Felton Williams at fwilliams@dekalbcountyga.gov or (404) 371-6312.

14. First Source Jobs Information

The DeKalb County First Source Jobs Ordinance requires contractors or beneficiaries entering into any type of agreement with the County, including purchase orders, regardless of what they may be called for the procurement or disposal of supplies, services, construction projects, professional or consultant services, which is funded in whole or part with County funds or County administered funds in which the contractor is to receive \$50,000 or more in County expenditures or committed expenditures and recipient of urban redevelopment action grants or community development block funds administered in the amount of \$50,000 or more make a good faith effort to hire DeKalb County residents for at least 50% of jobs using the First Source Registry (candidate database). The work to be performed under this contract is subject to the provisions of the DeKalb County First Source Jobs Ordinance.

For more information on the First Source Jobs Ordinance requirement, please contact WorkSource DeKalb at www.dekalbworkforce.org or 404-687-3400.

15. Attention to General Terms and Conditions

Bidders are cautioned to thoroughly understand and comply with all matters covered under the General Terms and Conditions section of this ITB. The successful Bidder(s) will enter into a contract approved by the County. The County's ITB document and attachments, subsequent County addenda, and the Bidder's response documents are intended to be incorporated into a contract. All Bidders should thoroughly review this document prior to submitting a bid. Any proposed revisions to the terms or language of this document must be submitted in writing with the bid. Since proposed revisions may result in a bid being rejected if the revisions are unacceptable to the County, bidders should review any proposed revisions with an officer of the firm having authority to execute the contract. No alterations can be made in the contract after award is made.

16. Required Signatures

Bids must be signed by an officer or agent of the firm having the authority to execute contracts.

17. Ethics Rules

Bidders are subject to the Ethics provision within the DeKalb County Purchasing Policy; the Organizational Act, Section 22A, the Code of DeKalb County; and the rules of Executive Order 2014-4. Any violations will be addressed, pursuant to these policies and rules.

To the extent that the Organizational Act, Section 22A, the Code of DeKalb County, and the rules of Executive Order 2014-4 allow a gift, meal, travel expense, ticket, or anything else of value to be purchased for a CEO employee by a contractor doing business with the County, the contractor must provide written disclosure, quarterly, of the exact nature and value of the purchase to the Chief Integrity Officer, if created, or the Finance Director or his/her designee. Every contractor conducting business with the County will receive a copy of these ethical rules at the time of execution of the contract.

18. Business License

Bidders shall submit a copy of its current, valid business license with its Bid. Georgia companies are to submit a valid county or city business license. Contractors that are not Georgia companies are to provide a certificate of authority to transact business in the State of Georgia and a copy of a valid business license issued by its home jurisdiction. If Bidder holds a professional certification which is licensed by the state of Georgia, then Bidder may submit a copy of its valid professional license with Bidder's bid or upon award unless the Minimum Specifications require submittal with the bid. Any license submitted in response to this ITB shall be maintained by the Contractor for the duration of the contract.

BID SUBMITTAL:

1. All bids should be completed in ink or typewritten. Errors should be crossed out and corrections entered in ink or typewritten adjacent to the error. The person signing the bid should initial corrections in ink.
2. Bidders shall complete and submit Attachment A - Required Documents Checklist and all documents responsive to this requirement with the bid submittal.
3. If applicable, provide evidence that the Bidder is a DeKalb County Firm.
4. Bids must be submitted in a sealed envelope(s) or box(es) with the Bidder's name and "ITB No. 19-101137 for Fence Installation Repairs" on the outside of each envelope or box. All Bidders delivering submittals via delivery services, please place the sealed bid envelope(s) or box(es) inside the delivery service envelope(s) or box(es). Bidders are responsible for informing any delivery service of all delivery

requirements. No responsibility shall attach to the County for the premature opening of a submission not properly addressed and/or identified. The Decatur postmaster will not deliver certified or special delivery mail to specific addresses within DeKalb County Government.

C. Contract Award:

1. Bids submitted will be evaluated and recommended for award to the lowest, responsive, and responsible Bidder(s).
2. The intent of this bid is to make an all-award; however, the County reserves the right to award by line item or multiple awards. The County may accept any item or group of items on any bid, whichever is in the best interest of DeKalb County.
3. The County reserves the right to reject any and all bids, to waive informalities, and to re-advertise.
4. The judgment of DeKalb County Purchasing and Contracting on matters, as stated above, shall be final. The County reserves the right to decide which Bid will be deemed lowest, responsive and responsible.

GENERAL TERMS AND CONDITIONS

- A. In the event of a conflict between any provisions contained in any of the documents governing this transaction, the following shall be the order of precedence: Change Orders or modifications; the Bidder's accepted bid; and the County's ITB.
- B. The Bidder's services shall include all things, personnel, and materials necessary to provide the goods or services that are in compliance with the specifications as authorized by the County.
- C. Bidder extends to the County the option to renew the contract for two (2) additional one year terms, under the same price(s), terms and conditions, and in accordance with Paragraph L, *Term*.

D. DELIVERY:

Delivery of services or goods will commence within five (5) calendar days upon request.

Bidder state agreement: Yes _____
No _____

Contact Person: _____

Telephone Number: _____ Cellular Phone Number: _____

Address: _____

Alternate delivery time *may* be considered provided it is so stated. Bidder state alternate terms for delivery or services below.

All prices are to be firm, F.O.B. Destination, Freight Prepaid and Allowed. This shall include delivered, unloaded, and placed in designated place. Delivery must be made between 9:00 A.M. and 2:30 P.M. Monday through Friday, unless otherwise required. The successful bidder shall give a 24-hour prior notice of delivery to Department or Division calling in the order, and must ask for caller's telephone number as well as Purchase Order form and address, since 24-hour Notice of Delivery is required. The County will unload after prior notice.

E. DELIVERIES BEYOND THE CONTRACTUAL PERIOD:

This contract covers all requirements that may be ordered, as distinguished from delivered, during the contract term. This is for the purpose of providing continuity of

supply by permitting the County to place orders as requirements arise in the normal course of supply operations. Accordingly, any order mailed (or received, if forwarded by other means than through the mail) to the Contractor on or before the expiration date of the contract, and providing for delivery within the number of days specified in the contract, shall constitute a valid order.

F. FOREIGN PRODUCTS:

DeKalb County prefers to buy items produced and/or manufactured in the United States of America; however, foreign products may be considered provided it is so stated. Bidder certifies that items offered on this bid is/are manufactured and produced in the United States.

Yes _____ No _____

If "No", state the exact location of plant or facility where items will be produced:

G. COUNTY REQUIREMENT:

The contract will be an "Indefinite Quantity" type with County requirements to be satisfied on an "as ordered" basis. The County makes no promise, real or implied, to order any quantity whatsoever. This invitation and resulting contract will provide for the normal requirements of DeKalb County, and contracts will be used as primary sources for the articles or services listed herein. Articles or services will be ordered from time to time in such quantities as may be needed. As it was impossible to determine the precise quantities of items described in this invitation that will be needed during the contract term, each contractor is obligated to deliver all articles and services that may be ordered during the contract term.

H. WARRANTY AND/OR GUARANTY:

Contractor warrants that its services under this Agreement shall be free of defects in materials and workmanship for a period of ninety (90) days. The Contractor shall not be liable for indirect, special, or exemplary damages. The Contractor shall be liable for direct damages.

I. SAMPLES & TESTING:

Samples of items, when required, must be submitted within the time specified, and unless otherwise specified by the County, at no expense to the County. If not destroyed by testing, samples will be returned at bidder's request and expense, unless otherwise specified by the Invitation to Bid. Since tests may require several days for completion, the County reserves the right to use a portion of any supplies before the results of the tests are known, without prejudice to any final adjustments, rejecting the unused portion of the delivery and payment will be made on an adjusted basis for the used portion. The

costs of inspections and tests of any item which fails to meet the advertised specifications shall be borne by the bidder.

J. LITERATURE:

When the bidder proposes to furnish another product, he is required to furnish, with his bid, literature describing the item(s) being offered. Failure to furnish this literature may result in the bid being deemed non-responsive.

K. SILENCE OF SPECIFICATIONS:

The apparent silence of these specifications and any supplemental specifications as to any details, or the omission from it of a detailed description concerning any point, shall be regarded as meaning that only the best commercial practices are to prevail and that only materials of first quality and correct type, size and design are to be used. All workmanship is to be first quality. All interpretations of this specification shall be made upon the basis of this statement, with County interpretation to prevail.

L. TERM:

The Contractor shall commence the Work under this Contract within ten (10) days from the acknowledgement of receipt of the Notice to Proceed ("Commencement Date"). The Initial Term of this Agreement shall be for twelve (12) calendar months, beginning on the Commencement Date. This annual contract comes with two (2) options to renew. Prior to the expiration of the Initial Term, the parties have the option to renew this agreement for a First annual Renewal Term of twelve (12) calendar months. Prior to the expiration of the First annual Renewal Term, the parties have the option to renew this Agreement for a Second annual Renewal Term of twelve (12) calendar months. Without further action by either party, this Agreement will terminate at the end of the Initial Term or at the end of each annual Renewal Term. Each option to renew must be exercised prior to the beginning of each annual Renewal Term and, is only effective upon adoption and approval by the DeKalb County Governing Authority and the Contractor in accordance with the terms of this Contract.

M. PRICING:

Alterations to the Price Schedule may result in the Bidder being deemed non-responsive and its bid may be rejected.

1. Price Reductions: If at any time after the date of award, the Contractor makes a general price reduction in the comparable price of any article or service covered by the contract to customers generally, an equivalent price reduction based on similar quantities and/or considerations shall apply to the contract for the duration of the contract period (or until the price is further reduced). Such price reduction shall be effective at the same time and in the same manner as the reduction in the price to customers generally. An occasional sale at a lower

price, or sale of distressed merchandise at a lower price, would not be considered a general price reduction under this paragraph. For purposes of this paragraph, a general price reduction shall mean any reduction in the price of an article or service offered:

- To Contractor's customers.
- In the Contractor's price schedule for the class of customers; i.e., wholesalers, jobbers, retailers, etc., which was used as the basis for bidding on this contract.

The Contractor shall invoice the County at such reduced price indicating on the invoice that the reduction is pursuant to General Terms and Conditions, paragraph I. as stated within the ITB.

2. Price Escalation Clause: During the life of the contract, the awarded bidder shall furnish price lists to the County for increases, and those of the bidder's supplier (e.g. factory) increases, as prices change. The bidder must also provide a list of the supplier's (e.g. factory's) previous price(s) to the County for purposes of comparison. Price changes will be in effect only after receipt and approval by the Director of the Department of Purchasing and Contracting. Price lists and changes thereto are to be furnished under the contract and without charge to the County. Catalogue(s) or Price List(s) must be submitted to the Department of Purchasing and Contracting, Maloof Administration Building, 1300 Commerce Drive, 2nd Floor, Decatur, Georgia 30030.
3. By submission of this bid, the bidder certifies, and in the case of a joint bid each party thereto certifies as to its own organization that in connection with this procurement:

The prices in this bid have been arrived at independently, without consultation, communication, or agreement, for the purpose of restricting competition, as to any matter relating to such prices with any other bidder or with any competitor,

Unless otherwise required by law, the prices which have been quoted in this bid have not been knowingly disclosed by the bidder and will not knowingly be disclosed by the bidder prior to opening, directly or indirectly to any other bidder or to any competitor: and

No attempt has been made or will be made by the bidder to induce any other person or firm to submit or not to submit a bid for the purpose of restricting competition.

N. PAYMENT:

1. The County shall pay the Contractor based upon the accepted bid prices submitted by Bidder. Invoices should be signed by the Bidder or authorized delegate and must contain the authorizing DeKalb County Purchase Order

(PO) and/or Contract Purchase Agreement (CPA) Number in order for payment to be processed. PO Number must also be on the delivery ticket.

A Contract Purchase Agreement is being issued in lieu of a formal contract. Any reference to a contract refers to the CPA.

2. Invoice(s) must be submitted as follows:

Vendor invoices:

Park Services Recreation, Parks and Cultural Affairs
Attn: Division Manager
3681 Chestnut Street
Scottsdale, GA 30079

For notices:

Chief Financial Officer
DeKalb County Department of Finance
1300 Commerce Drive, 6th Floor
Decatur, GA 30030

- a. Upon award, Prime Contractor(s) with Local Small Business Enterprise (LSBE) Subcontractor(s) shall enter utilization reports electronically at www.dekalbblsbe.info. Proof of payment to the LSBE Subcontractor must be uploaded and submitted. LSBE Subcontractors shall confirm receipt of payment from the Prime, electronically also, at www.dekalbblsbe.info.

3. The County's official payment terms are Net 30. Payment dates that fall on a weekend or on a holiday will be issued on the County's next business day.

O. ACCURACY OF WORK:

The Contractor shall be responsible for the accuracy of the Work and any error and/or omission made by the Contractor in any phase of the Work under this Agreement.

P. ADDITIONAL WORK:

The County shall in no way be held liable for any work performed under this section which has not first been approved in writing by the County in the manner required by applicable law and/or the terms of this Contract. The County may at any time order changes within the scope of the Work without invalidating the Contract upon seven (7) days written notice to the Contractor. The Contractor shall proceed with the performance of any changes in the Work so ordered by the County unless such change entitles the Contractor to a change in Contract Price, and/or Contract Term, in which event the Contractor shall give the County written notice thereof within fifteen (15) days after the receipt of the ordered change, and the Contractor shall not execute such changes until it receives an executed Change Order from the County. No extra cost or extension of time shall be allowed unless approved by the County and authorized by

execution of a Change Order. The parties' execution of any Change Order constitutes a final settlement of all matters relating to the change in the Work which is the subject of the Change Order. The County shall not be liable for payment for any work performed under this section which has not first been approved in writing by the County in the manner required by applicable law and/or the terms of this Contract.

Q. OWNERSHIP OF DOCUMENTS:

All documents, including drawings, estimates, specifications, and data are and remain the property of the County. The Contractor agrees that the County may reuse any and all plans, specifications, drawings, estimates, or any other data or documents described herein in its sole discretion without first obtaining permission of the Contractor and without any payment of any monies to the Contractor therefore. Any reuse of the documents by the County on a different site shall be at its risk and the Contractor shall have no liability where such documents are reused.

R. RIGHT TO AUDIT:

The County shall have the right to audit all books and records, including electronic records, relating or pertaining to this contract or agreement, including but not limited to all financial and performance related records, property, and equipment purchased in whole or in part with County funds and any documents or materials which support those records, kept under the control of the Contractor, including but not limited to those kept by the Contractor's employees, agents, assigns, successors and subcontractors. The County also has the right to communicate with Contractor's employees related to the audited records.

The Contractor shall maintain such books and records, together with such supporting or underlying documents and materials, for the duration of this contract and for seven (7) years after termination or expiration, including any and all renewals thereof. The books and records, together with supporting documents and materials shall be made available, upon request to the County or its designee, during normal business hours at the Contractor's office or place of business. In the event that no such locations is available, then the books, records and supporting documents shall be made available for audit at a time and location which is convenient for the County.

S. SUCCESSORS AND ASSIGNS:

The Contractor agrees it shall not sublet, assign, transfer, pledge, convey, sell, or otherwise dispose of the whole or any part of this Contract or his right, title, or interest therein to any person, firm, or corporation without the previous written consent of the County. If the County consents to any such assignment or transfer, then the Contractor binds itself, its partners, successors and assigns to all covenants of this Contract. Nothing contained in this Contract shall create, nor be interpreted to create privity, or any other relationship whatsoever, between the County and any person, or entity or than Contractor.

T. REVIEWS AND ACCEPTANCE:

Work performed by the Contractor shall be subject to review and acceptance in stages as required by the County. Acceptance shall not relieve the Contractor of its professional obligation to correct, at his own expense, any errors in the Work.

U. TERMINATION OF AGREEMENT:

The Contractor understands and agrees that the date of the beginning of Work, rate of progress, and time for completion of the Work are essential conditions of this Contract. Both parties may, for its own convenience and at its sole option, without cause and without prejudice to any other right or remedy of the party, elect to terminate the Contract by delivering to the other party, at the address listed in the Notices article of this Contract, a written notice of termination specifying the effective date of termination. Such notice shall be delivered to the other party at least thirty (30) days prior to the effective date of termination. If Contractor's services are terminated by the County, the termination will not affect any rights or remedies of the County then existing or which may thereafter accrue against Contractor or its surety.

In case of termination of this Contract before completion of the Work, Contractor will be paid only for the portion of the Work satisfactorily performed through the effective date of termination as determined by the County. Neither party shall be entitled to recover lost profits, special, consequential or punitive damages, attorney's fees or costs from the other party to this Contract for any reason whatsoever. This Contract shall not be deemed to provide any third-party with any remedy, claim, right of action, or other right. The parties' obligations pursuant to this Section shall survive any acceptance of Work, or termination or expiration of this Contract.

V. INDEMNIFICATION AGREEMENT:

The Contractor shall be responsible from the execution date or from the time of the beginning of the Work, whichever shall be the earlier, for all injury or damage of any kind resulting from the Work, to persons or property, including employees and property of the County. The Contractor shall exonerate, indemnify, and save harmless the County, its elected officials, officers, employees, agents and servants, hereinafter collectively referred to in this Section as "the County Indemnitees," from and against all claims or actions based upon or arising out of any damage or injury (including without limitation any injury or death to persons and any damage to property) caused by or sustained in connection with the performance of this Contract or by conditions created thereby or arising out of or any way connected with Work performed under this Contract, as well as all expenses incidental to the defense of any such claims, litigation, and actions. Furthermore, Contractor shall assume and pay for, without cost to the County Indemnitees, the defense of any and all claims, litigation, and actions suffered through any act or omission of the Contractor, or any Subcontractor, or anyone

directly or indirectly employed by or under the supervision of any of them. Notwithstanding any language or provision in this Contract, Contractor shall not be required to indemnify any County Indemnitee against claims, actions, or expenses based upon or arising out of the County Indemnitee's sole negligence. As between the County Indemnitees and the Contractor as the other party, the Contractor shall assume responsibility and liability for any damage, loss, or injury, including death, of any kind or nature whatever to person or property, resulting from any kind of claim made by Contractor's employees, agents, vendors, Suppliers or Subcontractors caused by or resulting from the performance of Work under this Contract, or caused by or resulting from any error, omission, or the negligent or intentional act of the Contractor, vendors, Suppliers, or Subcontractors, or any of their officers, agents, servants, or employees. The Contractor shall defend, indemnify, and hold harmless the County Indemnitees from and against any and all claims, loss, damage, charge, or expense to which they or any of them may be put or subjected by reason of any such damage, loss, or injury. The Contractor expressly agrees to provide a full and complete defense against any claims brought or actions filed against the County Indemnitees, where such claim or action involves, in whole or in part, the subject of the indemnity contained in this Contract, whether such claims or actions are rightfully or wrongfully brought or filed. The County has the sole discretion to choose the counsel who will provide the defense. No provision of this Contract and nothing herein shall be construed as creating any individual or personal liability on the part of any elected official, officer, employee, agent or servant of the County, nor shall the Contract be construed as giving any rights or benefits hereunder to anyone other than the parties to this Contract. The parties' obligations pursuant to this Section shall survive any acceptance of Work, or termination or expiration of this Contract.

W. INSURANCE:

Insurance must meet the County's requirements and will be furnished by the successful Bidder(s) upon award.

1. Successful Bidder(s) will advise their insurance agent of the County's requirements as listed below and that they may not proceed with any work until insurance is provided that is in compliance with these requirements.
2. Contractor's insurance company or agent must mail, email, or bring an original certificate of insurance and applicable declarations or endorsements to the DeKalb County address listed within this Insurance provision. Insurance must be from companies able to do business in Georgia and acceptable to the County as follows:
 - a. Certificates must cover:
 - i. Statutory Workers Compensation
 - (1) Employer's liability insurance by accident, each accident \$1,000,000
 - (2) Employer's liability insurance by disease, policy limit \$1,000,000

(3) Employer's liability insurance by disease, each employee
\$1,000,000

ii. Business Auto Liability Insurance with a minimum \$500,000
Combined Single Limit/Each Occurrence (Including operation
of non-owned, owned, and hired automobiles).

iii. Commercial General Liability Insurance

- (1) Each Occurrence - \$1,000,000
- (2) Fire Damage - \$250,000
- (3) Medical Expense - \$10,000
- (4) Personal & Advertising Injury - \$1,000,000
- (5) General Aggregate - \$2,000,000
- (6) Products & Completed Operations - \$1,500,000
- (7) Contractual Liability where applicable

- b. DeKalb County, GA shall be named as Additional Insured under any General Liability, Business Auto and Umbrella Policies. Coverage shall apply as Primary and non-contributory with Waiver of Subrogation in favor of DeKalb County, Georgia. Such additional insured coverage shall be endorsed to Contractor's policy by attachment of ISO Additional Insured Endorsement forms CG 20 10 10 01 (ongoing operations) and CG 20 37 10 01 (products- completed operations), or form(s) providing equivalent coverage.
- c. This insurance for the County as the additional insured shall be as broad as the coverage provided for the named-insured Contractor. It shall apply as primary insurance before any other insurance or self-insurance, including any deductible, non-contributory, and waiver of subrogation provided to the County as the additional insured.
- d. Contractor agrees to waive all rights of subrogation and other rights of recovery against the County and its elected officials, officers, employees or agents, and shall cause each Subcontractor to waive all rights of subrogation for all coverages.
- e. Certificates shall state that the policy or policies shall not expire, be cancelled or altered without at least sixty (60) days prior written notice to the County.
- f. Contractor understands and agrees that the purchase of insurance in no way limits the liability of the Contractor.

- g. The insurance carrier must have a minimum A.M. Best rating of not less than "A" (Excellent) with a Financial Size Category of VII or better.
- h. Certificates to contain policy number, policy limits and policy expiration date of all policies issued in accordance with this contract.
- i. Certificates to contain the location and operations to which the insurance applies.
- j. Certificates to contain successful contractor's protective coverage for any subcontractor's operations. If this coverage is included in General Liability, please indicate on the Certificate of Insurance.
- k. Certificates to contain successful contractor's contractual insurance coverage. If this coverage is included in the General Liability, please indicate this on the Certificate of Insurance.
- l. Certificates shall be issued and delivered to the County and must identify the "Certificate Holder" as follows:

DeKalb County, Georgia
Director of Purchasing and
Contracting
Maloof Administration
Building
1300 Commerce Drive, 2nd Floor
Decatur, Georgia 30030
- m. The successful contractor shall be wholly responsible for securing certificates of insurance coverage as set forth above from all subcontractors who are engaged in this work.

X. GEORGIA LAWS GOVERN:

The laws of the State of Georgia shall govern the construction of this Contract without regard for conflicts of laws. Should any provision of this Contract require judicial interpretation, it is agreed that the court interpreting or construing the same shall not apply a presumption that the terms hereof shall be more strictly construed against one party, by reason of the rule of construction, that a document is to be construed more strictly against the party who itself or through its agent prepared same; it being agreed that the agents of all parties have participated in the preparation hereof, and all parties have had an adequate opportunity to consult with legal counsel. In interpreting this Contract in its entirety, the printed provisions of this Contract, and any additions written or typed hereon, shall be given equal weight, and there shall

be no inference by operation of law or otherwise; that any provision of this Contract shall be construed against either party hereto.

Y. VENUE:

This Agreement shall be deemed to have been made and performed in DeKalb County, Georgia. For the purposes of venue, all suits or causes of action arising out of this Agreement shall be brought in the courts of DeKalb County, Georgia.

Z. COUNTY REPRESENTATIVE:

The County may designate a representative through whom the Contractor will contact the County. In the event of such designation, said representative shall be consulted and his written recommendation obtained before any request for extra work is presented to the County. Payments to the Contractor shall be made only upon itemized bill submitted to and approved by said representative.

AA. CONTRACTOR'S STATUS:

The Contractor will supervise and direct the Work, including the Work of all Subcontractors. Only persons skilled in the type of work which they are to perform shall be employed. The Contractor shall, at all times, maintain discipline and good order among his employees, and shall not employ any unfit person or persons or anyone unskilled in the work assigned him. The relationship between the County and the Contractor shall be that of owner and independent contractor. Other than the consideration set forth herein, the Contractor, its officers, agents, servants, employees, and any Subcontractors shall not be entitled to any County employee benefits including, but not limited to social security, insurance, paid annual leave, sick leave, worker's compensation, free parking or retirement benefits. All services provided by Contractor shall be by employees of Contractor or its Subcontractors and subject to supervision by Contractor. No officer or employee of Contractor or any Subcontractor shall be deemed an officer or employee of the County. Personnel policies, tax responsibilities, social security payments, health insurance, employee benefits and other administrative policies, procedures or requirements applicable to the Work or services rendered under this Contract shall be those of the Contractor, not the County.

BB. SOLE AGREEMENT:

This Contract constitutes the sole contract between the County and the Contractor. The terms, conditions, and requirements of this Contract may not be modified. No verbal agreement or conversation with any officer, agent, or employee of the County, either before or after the award of the Contract, shall affect or modify any of the terms or obligations herein contained. No representations, oral or written, shall be binding on the parties unless expressly incorporated herein.

CC. SEVERABILITY:

If any provision of this Contract or the application thereof to any person or circumstance shall to any extent be held invalid, then the remainder of this Contract or the application of such provision to persons or circumstances, other than those as to which it is held invalid, shall not be affected thereby, and each provision of this Contract shall be valid and enforced to the fullest extent permitted by law.

DD. NOTICES:

Any notice or consent required to be given by or on behalf of any party hereto to any other party hereto shall be in writing and shall be sent to the Director of the Department of Purchasing and Contracting or to the Contractor or his authorized representative on the work site by (a) registered or certified United States mail, return receipt requested, postage prepaid, (b) personal delivery, or (c) overnight courier service. All notices sent to the addresses listed below shall be binding unless said address is changed in writing no less than fourteen days before such notice is sent. Future changes in address shall be effective upon written notice being given by the Contractor to the Director of the Department of Purchasing and Contracting or by the County to the Contractor's authorized representative via certified first class U.S. mail, return receipt requested. Such notices will be addressed as follows:

If to the County:

Chief Procurement Officer
Department of Purchasing and Contracting
Maloof Administration Building
1300 Commerce Drive, 2nd Floor
Decatur, Georgia 30030

If to the Contractor:

Notices shall be sent to the contact information that is listed in the Bidder's Response to the ITB.

EE. Georgia Open Records Act:

Without regard to any designation made by the person or entity making a submission, DeKalb County considers all information submitted in response to this invitation or request to be a public record that will be disclosed upon request pursuant to the Georgia Open Records Act, O.C.G.A. §50-18-70 et seq., without consulting or contacting the Responder person or entity making the submission, unless a court order is presented with the submission. Bidders or Responders may wish to consult an attorney or obtain legal advice prior to making a submission.

FF. Cooperative Procurement

The County through the Department of Purchasing & Contracting may permit piggybacks to this contract from other city, county, local authority, agency, or board of education if the vendor will extend the same prices, terms, and conditions to the city. Piggybacking shall only be available where competition was used to secure the contract and only for a period of 12-months following entry, renewal or extension of the contract. This provision shall not apply to any contract where otherwise prohibited or mandated by state law.

MINIMUM SPECIFICATIONS

1.0 GENERAL REQUIREMENTS:

SCOPE OF WORK

DeKalb County is seeking bids from qualified bidders to provide fence installation and repairs for the DeKalb County's Recreation, Parks and Cultural Affairs Department, in accordance with the terms, conditions, and specifications contained in this Invitation to Bid (ITB). Work request may range from large, new installation or repairs to small quantity fence repairs.

Due to the number and variety of locations, site inspections at the County's request for repair or installation for specific sites will be conducted.

The Contractor must state clearly in their bid pages any variance to the specifications. If proposing an approved equal or alternate product, it will be the Contractor's responsibility to provide adequate information in their bid to enable the County to ensure that the Contractor meets the required criteria.

DeKalb County will be the sole judge in determining if the product proposed qualifies as approved equal. The County reserves the right to award to that Contractor which will best serve the interest of the County as determined by the County.

Contractor shall have a minimum of five (5) years of continuous business serving accounts similar in size and layouts with experienced installers providing the installation services required.

Contractor must quote a firm, fixed price for all products/services stated in the ITB, which includes any travel associated with coming to DeKalb County. All prices quoted shall include delivery/handling charges. DeKalb County will not accept any bids that do not guarantee a firm price.

Work will be authorized by written work and a purchase order. A list of employees authorized to direct work, will be provided to the successful bidder upon award. The Contractor's pricing shall reflect to furnish all labor, equipment and tools required for the installation and repair of all fencing included within the bid schedule, including required pickup and transport, in accordance with the specifications of this bid and to supply required equipment and labor to remove, haul and properly dispose of any debris or excess fill material as developed during the fulfillment of this contract. Pricing shall include providing and furnishing all labor, materials, and equipment to perform the operations required, specified or directed by the owner to properly complete the work stated herein. The work scope includes, but is not limited to the following items: Remove existing fence poles, pole foundations, railings, gates and fence fabric.

2.0 GENERAL CONDITIONS

2.1 Personnel

The contractor shall have a competent superintendent or foreman on the job during the progress of the work who has full authority to supervise and direct the work and who shall be the contractor's agent for the faithful discharge of the contractor's obligation under this contract. The superintendent or foreman shall represent the contractor in his absence. Each crew shall have at least one crewmember that communicates in English (both orally and in writing) and comprehends the English language. This crewmember shall communicate instructions to other crewmembers or coordinate this communication. The English used by this person must be understood by DeKalb personnel. Additionally, any crew member that is used as a flagger shall speak only English while performing this duty as required.

2.2 Measurement

Chain-link fence will be measured for payment by the linear foot. Measurement will be along the top of the fence from center to center of end posts, excluding the length occupied by gate openings.

The quantities of work in the Bid section of this contract are rough approximations only. The total quantities of work to be included in this contract and actually performed may vary widely and some items may be completely eliminated depending upon the work that will be authorized by the County during the period of this contract, by field conditions or availability of funds

2.3 Payment

Payment for chain-link fence will be made at the contract unit price per linear foot. Payment for driveway or walkway gates will be made at the contract unit price for each gate. The price shall be full compensation for furnishing all materials, and for all preparation, erection, and installation of these materials, and for all labor equipment, tools, and incidentals necessary to complete the item.

2.4 Task Orders

Work will be assigned on an as-needed basis, as determined by the DeKalb Representative. Contractor shall report to the work site within five (5) days after notification, unless otherwise mutually agreed to. All work performed under this contract shall be performed Monday through Friday, 7am to 3:30pm, excluding major holidays, during daylight hours, weather conditions permitting. Lunch periods are excluded from payment. Saturday work may be performed if approved in advance by the DeKalb representative. Work will not be performed on any state or federal holidays unless prior approval in writing has been granted by the department designee.

2.5 Utility Locate 811

The Contractor shall contact "Utility Locate 811" to locate all underground utilities including those installed by DeKalb prior to performing work. There may be some instances when contractor will be unable to locate all utilities using due diligence and underground locating equipment such as the ditch witch brand utility locator and signal sensors. When this occurs it shall be the contractor's responsibility to locate utilities before excavating. By means of digging by hand or request special approval from Contract Administrator to use a sub-contractor for this function.

Contractor shall secure all utility locates for repair locations and installation of new fence or posts and provide confirmation as requested to verify locate.

Contractor shall repair or correct any damage caused to underground and/or overhead utilities in the installation and/or repair of fencing, at no additional cost to the County.

2.6 Site Conditions

The contractor will ensure temporary fencing is in place each day prior to leaving the project for security purposes. Each roll of fabric shall carry a tag showing the kind of base metal (steel, aluminum, or aluminum alloy number), kind of coating, the gauge of the wire, the length of fencing in the roll, and the name of the manufacturer. Posts, wire, and other fittings shall be identified as to manufacturer, kind of base metal (steel, aluminum, or aluminum alloy number), and kind of coating.

When required, the contractor must apply for and obtain a building permit. The contractor will be responsible for all design and drawings as well as permit applications. Contractor will be reimbursed for permit cost (refer to line item 206.)

Suitable barricades and lights shall be placed by the Contractor to protect the public prior to the installation and/or removal of assigned fencing projects and shall remain until the work is completed. Barricades and lights shall be removed as soon as possible thereafter. Ensure property lines and legal boundaries of work are clearly established.

No handling or placement of concrete footings shall be accomplished during rainfall or when rainfall is imminent. No such work shall start unless the air temperature at the site is at least forty (40) degrees Fahrenheit, and rising. The replacement and repairs of existing fencing and appurtenances shall consist of using materials of the same type found at each location unless otherwise approved or directed by the Department Designee.

Upon request, contractor shall be required to remove the existing fence, posts, and foundations from the DeKalb County Property and maintain a safe and secure perimeter at the site. Disposal of any materials, natural or unnatural will not be permitted on DeKalb property unless prior approval is obtained and coordinated with the owner.

Contractor shall fill and compact all holes, depressions and low areas at the bottom of the newly installed fence along its entirety to insure that animals and objects cannot get through. Contractor is responsible for removing spoils, construction debris, litter, trash and any miscellaneous materials from the site on a daily basis.

When removing fencing and not installing replacement fencing, the Contractor shall provide material and labor to backfill the excavation hole to a level even with surrounding

grade lines. The Contractor shall be responsible to furnish additional fill if required (refer to line item 207). Contractor shall haul and dispose of any and all debris or fill developed as a result of removal, installation or repair under this contract, at no additional cost to the County. All trees, brush, stumps, logs, and other debris which would interfere with the proper construction of the fence in the required location shall be removed a minimum width of 2 feet on each side of the fence centerline before starting fencing operations. The cost of removing and disposing of the material shall not constitute a pay item and shall be considered incidental to fence construction.

2.7 Damages

Contractor shall replace and/or repair any property damaged by his work or workmen, including repairs to lawns, pavements, buildings, utilities and furnishings. Contractor shall repair and pay for damage to existing landscape during the fence repair or the installation of new fence sections.

Contractor shall be held responsible for any damage done by him or his agents to work performed by another Contractor.

Contractor shall repair or correct to the satisfaction of the County, any damage to County and/or private property as a result of fence installation and/or repairs, at no additional cost to the County. This includes, but is not limited to: repair to concrete sidewalks or medians. Damage to public and/or private property shall be the responsibility of the Contractor and shall be repaired and/or replaced in a timely fashion at no additional cost to the County.

Any fencing material either purchased damaged, or damaged during handling, transporting or installation by the Contractor, shall be replaced at the expense of the Contractor.

Any variances to the specifications need to be approved by the Department Designee.

3.0 MATERIALS

3.1 Posts

Terminal posts and End posts shall be 3" O.D., schedule 40, for heights 6', 8', 10', and 2 1/2" O.D. Schedule 40 for 4' heights. All pull posts, line posts, corner posts shall be 2 1/2" OD, schedule 40, See Table A.

3.2 Rails

All top rails, bottom rails or center rails shall be 1 5/8" O.D., schedule 40.

3.3 Sleeves

Top rail sleeves shall be 6" long galvanized steel.

3.4 Top Loop Caps, Dome Caps and Rail End Caps

All top loop, dome and rail end caps shall be of galvanized cast steel or cast aluminum.

3.5 Tension Bars

Tension bars shall be ¾ inch wide by 3/16 inch, galvanized

3.6 Tie Wire

Tie wire shall be 8 ½ inch long, 9 gauge aluminum.

PVC-Coated Tension Wire shall be manufactured in accordance with ASTM 1664, which requires a heavy-duty 7-gauge, 0.177-inch metallic coated core wire having a breaking strength of 1,950 lbf. The PVC coating shall be Class 2 fused and bonded to metallic-coated steel wire. Wire ties for use in conjunction with a given type of fabric shall be of the same material and coating weight identified with the fabric type. Tension wire shall be 7-gauge marcelled steel wire with the same coating as the fabric type and shall conform to ASTM A-824. All material shall conform to Fed. Spec. RR-F-191/4.

3.7 Truss Rods and Tighteners

Truss rods and tighteners shall be of galvanized steel

3.8 Boulevard Clamps

Boulevard clamps shall be pressed steel, galvanized.

3.9 Spring Tension Wire

Spring tension wire shall be 7 gauge, galvanized.

3.10 Hog Rings

Hog rings shall be of 7 gauge steel, galvanized

3.11 Hinges

All hinges shall be heavy duty industrial hinges, malleable and galvanized. Both male and female sections of hinges must be heavy duty with same size bolts.

3.12 Barbed Wire

PVC-Coated Barbed Wire shall be manufactured in accordance with ASTM F 1665 which requires 2 strands of 14-gauge, 0.08 inch metallic coated core wire with four-point 14-gauge, 0.08 inch zinc coated barbs. The PVC coating shall be Class 2 fused and bonded to metallic-coated steel wire.

3.12.1 Barbed wire shall be 2-strand 12-1/2 gauge zinc-coated wire with 4-point barbs and shall conform to the requirements of ASTM A-121, Class 3 and chain link fence grade.

3.12.2 Barbed wire support arms shall withstand a load of 250 pounds applied vertically to the outermost end of the arm.

3.13 Concrete

The concrete shall be commercial grade with a minimum 28-day compressive strength of 3,000 p.s.i. metal

3.14 Fabric

- 3.14.1** Mesh fence fabric shall be nine (9) gauge grade two (2) wire or six (6) gauge dipped galvanized after fabrication with not less than 1.2 oz. of zinc per square foot, in a two (2) inch link mesh, unless for tennis court fence which is 1 ¾" link mesh.
- 3.14.2** PVC coated fabric shall be thermally fused and bonded to a primer which is thermally cured onto galvanized steel core wire conforming to ASTM F 668, Class 2. Minimum coating thickness shall be 0.007 in.
- 3.14.3** Fabric shall be woven into 2 in. mesh of 9-gauge galvanized wire core with a minimum breaking strength of 1,290 lbs./ft. in accordance with ASTM F 668, Class 2. Coated wire size shall be 9 gauge core. Other gauges or mesh openings, such as the tennis courts, may be required as noted within the bid schedule.
- 3.14.4** Zinc for galvanized coating shall conform to ASTM b 6, galvanized by hot dipped method AISI Type 1, before vinyl coating; coating shall be smooth. Minimum weight of zinc coating shall be 1.2 oz. per sq. ft. (0.30 oz./ft.).
- 3.14.5** Polyvinyl chloride coating shall meet the following requirements:
- Specific gravity shall be 1.30 maximum, tested in accordance with ASTM D 792.
 - Hardness shall be a minimum Durometer reading of A 95 in accordance with ASTM D 2240. Ultimate elongation shall be 275% in accordance with ASTM D 412.
 - Tensile strength shall have a test minimum of 3,300 p.s.i. in accordance with ASTM D 412
 - Vinyl shall be a dense and impervious covering free of voids, having a smooth, lustrous surface without pinholes, bubbles, voids, or rough or blistered surface.
- 3.14.6** Fabric shall be knuckled at bottom and top.
- 3.14.7** Fence fabric color shall be black if vinyl coated.
- 3.14.8** Miscellaneous steel fittings and hardware for use with zinc-coated steel fabric shall be of commercial grade steel or better quality, wrought or cast as appropriate to the article, and sufficient in strength to provide a balanced design when used in conjunction with fabric posts, and wires of the quality specified herein. All steel fittings and hardware shall be protected with a zinc coating applied in conformance with ASTM A-153.

4.0 INSTALLATION:

4.1 General

All installations shall have the grade prepared and surface irregularities removed, if any, which may cause interference with the installation.

All trees, brush, stumps, logs, and other debris which would interfere with the proper construction of the fence in the required location shall be removed a minimum width of 2 feet on each side of the fence centerline before starting fencing operations. The cost of removing and disposing of the material shall not constitute a pay item and shall be considered incidental to fence construction.

Contractor shall clean jobsite of excess materials; posthole excavations shall be scattered uniformly and away from posts.

Contractor shall clean up debris and unused material, and remove from the site.

4.2 Installing Rails, top, bottom and center (Black Vinyl, Galvanized, Backstop)

The top rail shall be continuous and shall pass through the post tops. The coupling used to join the top rail lengths shall allow for expansion.

4.3 Installing Braces

Horizontal brace rails, with diagonal truss rods and turnbuckles, shall be installed at all terminal posts.

4.4 Installing Fabric (Black Vinyl, Galvanized, Backstop, and Tennis)

All voids shall be filled so bottom of fence and tension wire meet ground as to not allow animal ingress.

The wire fabric shall be firmly attached to the posts and shall be stretched taut. The fence shall generally follow the contour of the ground, with the bottom of the fence fabric no less than 1 inch or more than 4 inches from the ground surface. Grading shall be performed where necessary to provide a neat appearance.

At locations of small natural swales or drainage ditches and where it is not practical to have the fence conform to the general contour of the ground surface, longer posts may be used and multiple strands of barbed wire stretched thereon to span the opening below the fence. The vertical clearance between strands of barbed wire shall be 6 inches or less. Both top and bottom of fabric shall be knuckled.

4.5 Installing Standard Gates and Gate Posts

Install gateposts in accordance with manufacturer's instructions.

Concrete set gateposts: Drill holes in firm, undisturbed or compacted soil. Holes shall have a minimum of 3 inches of concrete on all sides of the post and approximately 3 inches of concrete deeper than post bottom. Excavate deeper as required for adequate support in soft and loose soils, and for posts with heavy lateral loads. Set post bottom 3'-6" below surface when in firm, undisturbed soil. Place concrete around posts in a continuous pour, tamp for consolidation. Trowel finish around post and slope to direct

water away from posts. Check each post for vertical and top alignment, and maintain in position during placement and finishing operations.

Install gates plumb, level, and secure for full opening without interference.

Attach hardware by means that will prevent unauthorized removal.

Adjust hardware for smooth operation.

Gate frames shall consist of galvanized steel pipe and shall conform to the specifications for the same material under paragraph 162-2.3 of the CHAIN LINK FENCE specifications. The fabric shall be of the same type material as used in the fence.

Verify areas to receive gate is completed to final grades and elevations.

Verify areas to assure sufficient space to receive gate in open position, (gate and overhang.)

4.6 Installing Posts

All posts shall be set in concrete at the required dimension and depth and at the spacing in Table A.

Posts should be spaced not more than 10 feet apart and should be set a minimum of 36 inches in concrete footings. The post holes shall be in proper alignment so that there is a minimum of 3 inches of concrete on all sides of the posts.

The concrete shall be thoroughly compacted around the posts by tamping or vibrating and shall have a smooth finish slightly higher than the ground and sloped to drain away from the posts. All posts shall be set plumb and to the required grade and alignment. No materials shall be installed on the posts, nor shall the posts be disturbed in any manner within 7 days after the individual post footing is completed.

Should rock be encountered at a depth less than the planned footing depth, a hole 2 inches larger than the greatest dimension of the posts shall be drilled to a depth of 12 inches.

After the posts are set, the remainder of the drilled hole shall be filled with grout, composed of one part Portland cement and two parts mortar sand. Any remaining space above the rock shall be filled with concrete in the manner described above.

In lieu of drilling, the rock may be excavated to the required footing depth. No extra compensation shall be made for rock excavation.

4.7 Installation of Aluminum fencing

Set fence posts at on-center (O.C.) distance set forth on post spacing guide included with the specifications. Set gateposts for gate openings specified in the construction drawings. Insert stringers into the pre-punched posts and fasten with stainless steel TEK screws. Center and align posts. Pour concrete around posts and vibrate or tamp for consolidation. Recheck vertical and top alignment of posts and make necessary adjustments prior to concrete setting.

Clean ornamental aluminum fence with a mild solution of household detergent and clean water. Rinse well. Mortar should be removed from exposed posts using a 10% solution of muriatic acid followed by immediate and thorough rinsing with clean water.

TABLE A

Fence Height	End Post Diameter	Line Post Diameter	Footing Depth	Typical Usage
4'	2 ½"	2 ½"	36"	Barrier Fence
6'	3"	2 ½"	36"	Some Barrier Fence, Outfield Fence
8'	3"	2 ½"	36"	Tennis Courts, Athletic Fields and pools
10'	3"	2 ½"	36"	Dugout to Maintenance Gate, Tennis Court Enclosures

5.0 SPECIFICATIONS ACCORDING TO LINE ITEM:

5.1 WOODEN SPLIT RAIL FENCE- 2 RAIL AND 3 RAIL, LINE ITEMS 1-5

- 5.1.1 All posts shall be installed at a maximum of ten feet (10') on center, plumbed and properly aligned.
- 5.1.2 Post holes shall be excavated to proper depth of 36" (3 Feet) and be thoroughly compacted with gravel spoils.
- 5.1.3 Top rail shall be installed at a height of approximately thirty eight (38") inches above grade.
- 5.1.4 Rails shall be attached via the standard method associated with mortise and Tenon post construction.
- 5.1.5 Rails shall be affixed in a manner to prevent vandals from removing fence pieces.
- 5.1.6 End posts shall be excavated and set in concrete.
- 5.1.7 All posts and rails shall be southern yellow pine, Ponderosa Pine, Red Pine, Douglas-Fir, Hem-Fir or Western Hemlock, No. 2 grade or better and vacuum-pressure treated with 0.40 ACQ Preserve or 0.40 ACQ Preserve Plus.
- 5.1.8 Split rail shall be constructed and installed as detailed on the attached photo see A and B.

5.2 WOOD GUARDRAIL – LINE ITEMS 6-8

- 5.2.1 Single row fence
- 5.2.2 All posts shall be installed at a maximum of eight feet (8') on center, plumbed and properly aligned. Notch posts as required.
- 5.2.3 Height of fence: 2.5 feet (30 inches) from ground to top of notch
- 5.2.4 Bottom of rail shall be 12" off the ground
- 5.2.5 Fence shall have 1 rail, 4 inch x 10 inch bolted to posts.

- 5.2.6 Posts shall be buried a minimum of 3 feet (36 inches) deep
- 5.2.7 Rails shall be secured with lag bolts, 2 at each end of rail, mounted to posts
- 5.2.8 Bolts shall be 1" diameter x 14" long galvanized lag bolts
- 5.2.9 Corner posts shall be concreted in ground
- 5.2.10 All line posts shall be concreted in ground
- 5.2.11 All posts and rails shall be southern yellow pine, Ponderosa Pine, Red Pine, Douglas-Fir, Hem-Fir or Western Hemlock, No. 2 grade or better and vacuum-pressure treated with 0.40 ACQ Preserve or 0.40 ACQ Preserve Plus.
- 5.2.12 Guardrail shall be constructed and installed as detailed on 5.2

5.3 WOOD BOLLARD – LINE ITEMS 9 AND 10.

- 5.3.1 Locking bollards will have a hole through the base with ½ inch rebar inserted. Rebar will be bent with a hole for a lock to be attached.
- 5.3.2 Removable bollards should have locking mechanisms.
- 5.3.3 All bollard posts shall be 6" x 6" and notched at 45 degrees
- 5.3.4 Additional notches shall be placed 5" from top of posts for 2" around bollard post.
- 5.3.5 Bollards shall be buried a minimum of 3 feet (36 inches) deep
- 5.3.6 Top of bollard shall be 2' 6" from the ground to top of notch.
- 5.3.7 Removable Bollard shall be placed in a 2' 6" steel sleeve in concrete in the ground
- 5.3.8 Bollards shall be planed ¼" on each side of 6" x 6" post
- 5.3.9 All posts shall be cedar.
- 5.3.10 Wood Bollard shall be constructed and installed as detailed on 5.3

5.4 UTILITY BOLLARD – LINE ITEM 11.

- 5.4.1 Bollard height shall be 36" from finished grade
- 5.4.2 Bollard shall be set in a 39" of 3000 psi concrete within a 12" diameter sonotube form.
- 5.4.3 Top of the sonotube form shall be 3" below grade and the base of the bollard shall be 3" from the base of the form.
- 5.4.4 Bollard diameter shall be 6" O.D.

5.4.5 Bollard shall be placed in a post sleeve, ¼" thick, 6" O.D.

5.4.6 Bollards shall be black or yellow

5.4.7 Utility Bollard shall be constructed and installed as detailed on detail 5.4

5.5 TEMPORARY (CHAIN LINK STYLE) FENCING – LINE ITEM 12.

5.5.1 Fencing shall be galvanized chain link style, approximately six (6) feet tall, and erected in place using moveable support bases. All fencing, including posts, wire fabric and support bases must be devoid of sharp or protruding edges that could be dangerous or harmful to bystanders and pedestrians. DeKalb County has the right to inspect all fencing material and refuse any materials for safety or aesthetic purposes.

5.5.2 Fence panels must be securely fastened or bonded together unless an opening is specified.

5.5.3 Fence openings: the fence must include fence panels that swing open and closed to secure the opening. Temporary fencing shall include installation and takedown by the vendor as requested by the County.

5.5.4 Ensure temporary fence is in place each day prior to leaving the project.

5.6 ALUMINUM FENCING AND GATES (ULTRA DEFENDER SPEAR TOP AND UAS-100 PLUGGED TOP) – LINE ITEMS 13-32 OR EQUAL

5.6.1 The contractor shall provide labor, materials and all necessary accessory items for the installation of the ornamental aluminum fence herein at each specified project location.

5.6.2 The manufacturer shall supply a total ornamental aluminum fencing system of the style, strength and color defined herein. The system shall be a total package including all components; pickets, posts, stringers, gates and hardware as required.

5.6.3 Install gates plumb, level and secure for full opening without interference. For double gates, install drop rod kit. Adjust all hardware for smooth operation.

5.6.4 The aluminum fencing material system shall be as manufactured by Ultra Aluminum Manufacturing Inc or equivalent. UAS-100 Plugged top fence and the Defender spear top (refer to detail 5.6.)

5.6.5 Stringers, (Horizontal rails) shall be punched to allow pickets to pass through the top of the rail. The number of stringers shall vary with the style, height and grade as determined by the manufacturer.

- 5.6.6 Pickets, (Vertical members) shall be fastened to stringers mechanically using stainless steel TEK screws on one side of the stringers only.
- 5.6.7 Posts, shall be pre-punched to allow the stringers to slide in and be fastened with stainless steel TEK screws. Cast aluminum post caps shall be affixed to all posts.
- 5.6.8 Gates shall be fabricated using the same components as for the complete fencing system. Walk gates shall have adjustable self-closing hinges and will be self-latching.
- 5.6.9 Fence posts shall be spaced 6' on center and shall have 4" x 4" x 0.125" walls. The posts shall be embedded 36" in 3000 psi concrete with a 3" exposure.
- 5.6.10 Refer to the dimensions table on detail 5.6 to determine the required specifications based on the height of the panels.
- 5.6.11 For 7' thru 10' heights, an added center rail shall be installed.
- 5.6.12 Gates come fully assembled and shall be installed to the height of the fence.
- 5.6.13 All gates shall be considered commercial gates and shall have standard spacing between pickets of 3- 5/8" unless specified otherwise.
- 5.6.14 All horizontal rails for gates shall be 1- 1/4" x 1 3/8" with 0.088" side walls and 0.065" top walls.
- 5.6.15 All posts for gates shall be either 2" square x 0.80, or 2 1/2" square x 0.100 and 3" square x 0.125.
- 5.6.16 All gates shall be high strength Ultrum 6005-T5 alloy, minimum strength 35,000 psi.
- 5.6.17 All fasteners shall be stainless steel
- 5.6.18 All pickets shall be 3/4" square by 0.055
- 5.6.19 **All aluminum fence shall be black**

5.7 RAMP HANDRAILS – LINE ITEMS 33 AND 34.

- 5.7.1 All posts will be equally spaced a maximum 6' apart and embedded 6" into 3000 psi concrete. Each hole shall be filled with non-shrinking grout.
- 5.7.2 Posts shall be 2" steel tube, schedule 40 with a square finial cap
- 5.7.3 All handrails shall be 1 1/2" O.D. steel tube, schedule 40

- 5.7.4 Bottom of lower mid-rail shall be 1' 7" from top of rail to finished grade of walkway surfacing
- 5.7.5 Handrails shall be spaced 1' 3" apart from mid-rail to mid-rail
- 5.7.6 End post shall be spaced 12" from end of handrail section.
- 5.7.7 Overall height shall be 2' 10" from top of finished grade of walkway surfacing
- 5.7.8 All handrails and posts to be painted black
- 5.7.9 Top of posts shall be exposed 4" from top of mid-rail.
- 5.7.10 Slope of handrail shall follow the slope of walkway surfacing.
- 5.7.11 Provide ¼" weep holes at bottom of posts and top with sealant.
- 5.7.12 All hand rails shall be black
- 5.7.13 Ramp handrail shall be constructed and installed as detail 5.7

5.8 HORSE PARK FENCE – LINE ITEMS 35-39

- 5.8.1 Double row fence with 8 feet in between rows O.C. (on center)
- 5.8.2 Height of fence: 5 feet (60 inches) from ground to top of fence
- 5.8.3 Bottom of fence shall be 6 inches off the ground
- 5.8.4 Fence shall be painted black with water-based paint
- 5.8.5 Fence shall have 4 rails, 2 inch x 6 inch treated pine boards with CCA (chromated copper arsenate at a minimum of 0.25 lb/ft³) spaced equally mounted at each post.
- 5.8.6 Fence shall be 8 inch by 8 inch wooden posts spaced equally at 8 feet on center for each row
- 5.8.7 Fence posts shall be treated lumber with CCA (chromated copper arsenate at a minimum of 0.4lb/ft³)
- 5.8.8 Fence posts shall be buried a minimum of 2 feet deep
- 5.8.9 Fence rails shall be secured with 3" coated decking screws, 6 screws per rail, 3 screws on each side of rail
- 5.8.10 Corner posts in paddock area shall be concreted in ground a minimum of 36" in 3000 psi concrete
- 5.8.11 All perimeter posts shall be concreted in ground a minimum of 36" in 3000 psi concrete

5.8.12 Horse Park fence shall be constructed and installed as on detail 5.8

5.9 HORSE PARK GATES – LINE ITEMS 40-46

5.9.1 Gates shall be painted red with final color chosen by the Recreation, Parks and Cultural Affairs Department

5.9.2 Gates shall be level with the height of the fence

5.9.3 Gate width may vary between 4 feet and 16 feet wide

5.9.4 Gates shall be hung to swing both ways

5.9.5 Gaps between the gates and supporting fence posts shall not have an opening greater than 1/8 inch

5.9.6 Gates shall be tubular and made of steel

5.9.7 All gate widths shall have (6), 2 inch tubular bars spaced equally horizontally across gate with top bar level with the fence and bottom bar 4 inches from the ground

5.9.8 For 4 foot wide gates use (2) 2 inch vertical tubular posts on each end.

5.9.9 Gate widths 6 feet and 8 feet shall have (3) 2 inch vertical tubular posts on each gate spaced equally apart.

5.9.10 Gate widths 10 feet through 16 feet wide shall have (4) 2 inch vertical tubular posts on each gate spaced equally apart.

5.9.11 Tubular posts and bars shall be 16 gauge material

5.9.12 Use (3), ¾ inch by 12 inch hinge pines and heavy duty welded chain latch

5.9.13 Gates shall have a wheel mounted at base of gate corner for easy opening and closing

5.10 PEDESTRIAN BOLLARD AND BOLLARDS WITH BLACK CHAIN - LINE ITEMS 47-51

5.10.1 For installation, the posts be no greater than 6 feet apart. Tight radius applications may require the posts to be even closer together.

5.10.2 Bollard shall be a 48" tall fence posts or 72" tall fence posts, spaced no greater than 6 on center, min 24" above grade or min 36" above grade as specified

5.10.3 Top of footing of bollard shall be 2" below finished grade

5.10.4 Concrete footing shall be min 27" below grade or 39" below grade as specified and 6" wide. Footing shall be exposed 3" on both sides of the bollard in 3000 psi concrete

- 5.10.5 Posts shall be 48" or 72" Central park cast aluminum post model #5200-72A.
- 5.10.6 Chain shall be hot dipped galvanized heavy duty landscape chain (1/4") Model #3429-21P.
- 5.10.7 Post and Chain to receive polyester powder coat finish, color: black as Manufactured by Snug Cottage Imports, Port Huron, MI 800-637-5427 or approved equal.
- 5.10.8 For installation, the posts be no greater than 6 feet apart. Tight radius applications may require the posts to be even closer together.
- 5.10.9 Posts should be installed in the ground approximately 50% of their length. The concrete column will vary in length depending upon the frost line (consult local building codes to establish). The concrete should extend at least 6 inches below the frost line to prevent heaving.
- 5.10.10 A "D" shackle (#3214) will be required for each start and stop. If joins in the chain are required use a joining link (#3022) for each join. We recommend that joins be situated at a post so it is the joining link that is in the notch on the post. In this way the join is hidden by the post cap. When ordering chain please allow approximately 10% more than the linear length (the distance between the posts) to allow for the extra chain that is required to allow for the sag in the chain.

5.10.11 See details 5.10a and 5.10b

5.11 SWING GATE LOCKABLE BOLLARD – PEDESTRIAN (WIDTHS 30", 36", 42", 48" AND 55")- LINE ITEMS 52-56

- 5.11.1 When installing two swing gates for pedestrian access, minimum opening between gates shall be 36".
- 5.11.2 A 3/4" diameter bent pin shall be used with provision for a padlock
- 5.11.3 Post shall be exposed 42" from top of finished grade.
- 5.11.4 Post shall be embedded in 3000 psi concrete a minimum of 36" deep. The post holes shall be in proper alignment so that there is a minimum of 3 inches of concrete on all sides of the posts
- 5.11.5 Post, shall be 3.5", O.D. diameter, schedule 40, for a pedestrian bollard
- 5.11.6 Swing gate shall be 20.67" tall. Top of gate shall be 40" maximum from finished grade.
- 5.11.7 Swing gates shall sleeve over post and shall not use any hinges.

5.11.8 Constructed of premium 2" O.D. (1-7/8" actual) galvanized HF40 or aluminum Schedule 40 gate framework

5.11.9 Post and gate shall be Belson model number B-35-GATE-42X55.

5.11.10 Gate and post to receive polyester powder coat finish, color: black as Manufactured by Belson, or approved equal.

5.11.11 Swing gate lockable bollard shall be constructed and installed as detailed on 5.11

5.12 SWINGING BARRIER GATES – VEHICULAR TUBULAR GATES, SINGLE AND DOUBLE, 4', 6', 8', 10', 12' WIDTHS – LINE ITEMS 57-66

5.12.1 Any swing gate over 12' wide shall have be a double gate.

5.12.2 All swing gates shall sleeve over post and shall not use any hinges.

5.12.3 When installing two swing gates for vehicular traffic over 12' wide, there shall be no opening between the gates. Gates shall join together level and plumb.

5.12.4 End posts shall be of heavy steel, 4" O.D.

5.12.5 Posts shall be embedded a minimum of 36" in 3000 psi concrete below finished grade. The post holes shall be in proper alignment so that there is a minimum of 3 inches of concrete on all sides of the posts

5.12.6 Top of sleeved post shall be 42" from existing grade.

5.12.7 Top of swing gate shall be 40" from existing grade.

5.12.8 Single and double swing gates of all widths shall have 2 vertical supports spaced equidistant from both end posts.

5.12.9 Schedule 40 shall be used for all components for the tubular barrier single and double gates.

5.12.10Swinging barrier gates and vehicular tubular gates shall be constructed and installed as detailed 5.12a and 5.12b

5.13 VEHICULAR HEAVY DUTY STEEL SINGLE GATES – 12', 14', 16', 18' WIDE –LINE ITEMS 67-70

5.13.1 Swing gate shall sleeve over post and shall not use any hinges.

5.13.2 Posts shall be of heavy steel, 6" x 6" square.

- 5.13.3 Posts shall be embedded a minimum of 36" in 3000 psi concrete below finished grade. The post holes shall be in proper alignment so that there is a minimum of 3 inches of concrete on all sides of the posts
- 5.13.4 Top of post shall be 36" from existing grade.
- 5.13.5 Top of swing gate shall be 30" from existing grade.
- 5.13.6 All gate components shall be constructed with heavy steel.
- 5.13.7 All gates shall be powder coated with black paint.
- 5.13.8 Overall height of gate shall be 24".
- 5.13.9 Gates shall consist of four steel tubes spaced vertically, one at each end and two equidistant from the ends.
- 5.13.10 Vehicular heavy duty steel single gates shall be constructed and installed as detailed on Detail 5.13

5.14 PEDESTRIAN SECURITY SWING GATES, 42", 48", 60", and 71" OPENINGS – LINE ITEMS 71-78

- 5.14.1 All pedestrian swing gates shall be Tymetal 2150 commercial series or equivalent , powder coated in black, with a panic bar on the interior, door closer, and exterior padlock combination.
- 5.14.2 Gate openings wide measured from inside edge of post to inside edge of post.
- 5.14.3 Gates shall be constructed with expanded perforated ornamental fencing or see detail 5.14a and 5.14 b

5.15 STANDARD FENCE GATES, SINGLE AND DOUBLE, VINYL BLACK COAT AND GALVANIZED, 3', 4', 6', 8', 10' OPENINGS LINE ITEMS 79-138

- 5.15.1 Gate frames shall consist of galvanized steel pipe, schedule 40, and shall conform to the specifications for the same material under section POSTS, RAILS AND BRACES. The fabric shall be of the same type material as used in the fence except for the gates at the horse park.
- 5.15.2 Pedestrian gates: Pedestrian gates opening shall be 36" wide measured from inside edge of post to inside edge of post.
- 5.15.3 Service Gates: Double service gate openings wide measured from inside edge of post to inside edge of post. Double wide gates use 4" O.D. posts, schedule 40. Posts shall be embedded in 3000 psi concrete a minimum of 36" deep. The post holes shall be in proper alignment so that there is a minimum of 3 inches of concrete on all sides of the posts.

5.15.4 Gate foundations and pole sizes must be sized and constructed appropriately to handle the weight loads and normal movement of the gate components. All gates shall be complete with posts and hardware.

5.15.5 Gates must swing freely unobstructed by ground or other objects, properly align and latch when closed.

5.15.6 All Hardware should meet ANSI specifications

5.16 BLACK VINYL COATED AND GALVANIZED FENCE 2" MESH and 1 3/4" MESH (4', 6', 8', 10, 12' IN HEIGHT) – LINE ITEMS 139-154

5.16.1 Line posts shall be two inch (2 1/2") O.D., Schedule 40. Installed at a maximum of ten feet (10') on center with concrete foundations 9 inches wide and 36 inches deep. The post holes shall be in proper alignment so that there is a minimum of 3 inches of concrete on all sides of the posts.

5.16.2 End posts shall be 3 inch O.D. (3"), Schedule 40, for 6', 8', and 10' heights and shall be 2 1/2" O.D., Schedule 40, for 4' heights installed at a maximum of ten feet (10') on center with concrete foundations 9 inches wide and 36 inches deep. The post holes shall be in proper alignment so that there is a minimum of 3 inches of concrete on all sides of the posts.

5.16.3 Top rail shall be one and five eighth inches O.D. (1-5/8"), Schedule 40.

5.16.4 Fabric shall be nine gauge or 6 gauge fused and double bonded galvanized wire sometimes specified with black vinyl coating.

5.16.5 Both top and bottom of fabric shall be knuckled.

5.16.6 All posts, rails and gate hardware must match color of black fabric when specified

5.16.7 This item shall consist of furnishing and erecting a chain-link fence in accordance with these specifications and the details as discussed on site and in writing prior to work starting.

5.16.8 All Hardware should meet ANSI specifications.

5.16.9 Tie wire may be substituted for either top or bottom railing or both when specified by the department designee.

5.16.10 When the height of fence exceeds 8' or higher or as required, a center rail 1 5/8" O.D. shall be used

5.16.11 For security purposes, 3 strands of barbed wire shall be considered standard

5.16.12 Fabric mesh size for tennis courts shall be 1 ¾" opening and shall contain an opening on each tennis courts to blow leaves from the courts. The opening shall be surrounded by 1 5/8" rails tie wired to the mesh. The opening shall be 10" tall by 36" wide.

5.17 BACKSTOP REQUIREMENTS- LINE ITEMS 155-170

5.17.1 Fabricated backstops will have three sections, one behind home plate centered 16' from the back of home plate to the back of the backstop fence, the others extending parallel to the foul line on either side. Backstops will have three 12' wide sections, 12' high. No overhang is necessary on any of the backstops. Netting shall extend 50' above the top rail of the fencing.

5.17.2 Post Spacing: All line posts shall be spaced at intervals not to exceed 10 feet when measured from center to center and shall be 3" O.D., schedule 40.

5.17.3 Post Setting: The posts are plumbed and embedded in a 36" hole filled with three thousand (3,000) psi concrete in order to reduce maintenance of grass and weeds on both sides. The post holes shall be in proper alignment so that there is a minimum of 3 inches of concrete on all sides of the posts

5.17.4 All fence fabric shall be black vinyl coated 2" mesh, 9 gauge 2 wire, hot dipped galvanized after fabrication with not less than ounce of zinc per square foot.

5.17.5 Seven gauge tension wire shall be wrapped across the bottom of the fabric to the posts, twisted with the ends down.

5.17.6 Center 1 5/8" Rails: Center rails shall be used for each corner, gate, or line post with a fabric height of 6' feet or higher.

5.17.7 Netting shall be installed 50' from the top of the backstop and shall be 1-7/8" square nylon mesh. The installation shall include all cable, cable hardware, posts and post hardware.

5.17.8 All netting shall be made from Dupont 66-728 or similar, 100% twisted knotted nylon netting which is UV protected. Nets shall come with rope borders around the perimeter of the whole net which is weaved in and out of each mesh and fastened in the corners.

5.17.9 Backstops shall be constructed and installed per detail 5.17

5.18 FENCE FABRIC – LINE ITEMS 171-180

Shall consist of removing the existing fence fabric, furnishing and installing new (unless otherwise specified type or size) fence fabric and all hardware and incidentals necessary to complete the work as specified

5.19 REALIGN AND ADJUST EXISTING FENCE – LINE ITEM 181

Shall consist of the realigning and re-compacting of posts and braces; the stretching and securing of the fencing fabric, barbed wire, and all hardware and incidentals necessary to complete the work.

5.20 REALIGN FENCE FABRIC – LINE ITEM 182

Shall incorporate the adjusting, stretching and retightening of existing fabric. And diagonal brace wire and all hardware and incidentals necessary to complete the work.

5.21 REALIGN POST – LINE ITEM 183

Shall incorporate the realignment, re-compacting and/or concreting, the re-securing of both fence fabric, braces and barbed wire to the post and all hardware and incidentals necessary to complete the work.

5.22 POST AND BRACE – LINE ITEMS 184-195

Shall incorporate the removal and replacement of existing posts and braces, inclusive of diagonal brace wires found in existing line brace, and corner brace units. When required the Contractor shall remove existing concrete footings and /or concrete blocks. The Contractor shall install the post and/or brace in accordance with the current standards for line or corner brace units and all hardware and incidentals necessary to complete the work.

5.23 ASTM STANDARDS TO APPLY TO LINE ITEMS 196-207

ASTM A-121

ASTM A-123 Zinc-Coated (Galvanized) Steel Barbed Wire.

Zinc (Hot Galvanized) Coatings on Products Fabricated from Rolled, Pressed, and Forged Steel Shapes, Plates, Bars, and Strip.

ASTM A-153 Zinc Coating (Hot-Dip) on Iron and Steel Hardware.

ASTM A-392 Zinc-Coated Steel Chain-Link Fence Fabric.

ASTM A-446 Specification for Steel Sheet, Zinc-Coated (Galvanized) by the Hot-Dip Process, Structural (Physical) Quality.

ASTM A-491 Aluminum-Coated Steel Chain-Link Fence Fabric.

ASTM A-569 Steel, Carbon (0.15 Maximum, Percent), Hot Rolled Sheet and Strip Commercial Quality.

ASTM A-570 Hot-Rolled Carbon Steel Sheet and Strip Structural Quality.

ASTM A-572 High-Strength Low-Alloy Columbium-Vanadium Steels of Structural Quality.

ASTM A-585 Aluminum-Coated Steel Barbed Wire.

ASTM A-824 Metallic-Coated Steel Marcellled Tension Wire for Use With Chain Link Fence.

ASTM B-117 Standard Test Method of Salt Spray (Fog) Testing.

ASTM B-221 Aluminum-Alloy Extruded Bars, Rods, Wire Shapes and Tubes.

ASTM F-668 Poly (vinyl Chloride)(PVC)-Coated Steel Chain-Link Fence.

ASTM F-1083 Pipe, Steel, Hot-Dipped Zinc-coated (galvanized) Welded, for Fence Structures.

ASTM F-1183 Aluminum Alloy Chain Link Fence Fabric.

ASTM F-1234 Protective Coatings on Steel Framework for Fences.

Fed. Spec. Fencing, Wire and Post, Metal (Chain-Link RR-F-191/3 Fence Posts, Top Rails and Braces).

Fed. Spec. Fencing, Wire and Post, Metal (Chain-Link RR-F-191/4 Fence Accessories).



PHOTO A
2 RAIL SPLIT RAIL



PHOTO B
3 RAIL SPLIT RAIL

PRICE SCHEDULE (pages 46-65)

***** PRICE SCHEDULE MUST BE SUBMITTED IN A SEPARATE SEALED ENVELOPE OR BIDDER WILL BE DEEMED NON-RESPONSIVE AND WILL NOT BE CONSIDERED FOR AWARD. INCLUDING THE PRICE SCHEDULE IN ANY AREA OUTSIDE OF THE SEPARATE SEALED ENVELOPE WILL RESULT IN THE BID BEING DEEMED NON-RESPONSIVE.*****

PRICE SCHEDULE (REFERS TO SECTION 5)

ITEM No.	ITEM DESCRIPTION	UNIT	UNIT PRICE
WOODEN SPLIT RAIL FENCE Refers to specifications, Section 5.1, refer to photos 5.1			
1	Wooden/split rail fence – 2 rail install including end posts in concrete (2)	LF	\$ _____
2	Wooden/split rail fence – 3 rail install including end posts in concrete (2)	LF	\$ _____
3	Split-rail, 10' length, includes nails	EACH	\$ _____
4	Wooden/split rail end posts, in concrete	EACH	\$ _____
5	Wooden corner post, in concrete	EACH	\$ _____
WOOD GUARDRAIL Refers to specifications, Section 5.2, refer to detail 5.2			
6	Wood guardrail, includes single row installation per specifications and hardware	LF	\$ _____
7	Wood guardrail only, includes hardware, 4'x10"	EACH	\$ _____
8	Posts only, line, corner and end, in concrete	EACH	\$ _____
WOOD BOLLARD Refers to specifications, Section 5.3, refer to detail 5.3			
9	Wood Bollard, locking (includes install and hardware)	EACH	\$ _____
10	Wood Bollard, stationary, (includes install and hardware)	EACH	\$ _____
UTILITY BOLLARD Refers to specifications, Section 5.4, refer to detail 5.4.			
11	Utility Bollard (includes install and sleeve)	EACH	\$ _____
TEMPORARY FENCING Refers to specifications 5.5, no detail			
12	Temporary fencing, includes support bases and fasteners	LF	\$ _____

ITEM No.	ITEM DESCRIPTION	UNIT	UNIT PRICE
ALUMINUM FENCING			
Refers to specifications, Section 5.6, detail 5.6			
13	Install aluminum fence 4' with plugged top, see spec, includes all hardware	LF	\$ _____
14	Install aluminum fence 6' with plugged top, see spec, includes all hardware	LF	\$ _____
15	Install aluminum fence 8' with plugged top, see spec, includes all hardware	LF	\$ _____
16	Install aluminum fence 10' with plugged top, see spec, includes all hardware	LF	\$ _____
17	Install aluminum fence defender 4' see spec, includes all hardware	LF	\$ _____
18	Install aluminum fence defender 6' see spec, includes all hardware	LF	\$ _____
19	Install aluminum fence defender 8' see spec, includes all hardware	LF	\$ _____
20	Install aluminum fence defender 10' see spec, includes all hardware	EACH	\$ _____
21	Install aluminum gate 36" wide and 4' tall includes all hardware	LF	\$ _____
22	Install aluminum gate 42" wide and 4' tall, includes all hardware	EACH	\$ _____
23	Install aluminum gate 48" wide and 4' tall, includes all hardware	EACH	\$ _____
24	Install aluminum gate 36" wide and 6' tall includes all hardware	EACH	\$ _____
25	Install aluminum gate 42" wide and 6' tall, includes all hardware	EACH	\$ _____
26	Install aluminum gate 48" wide and 8' tall, includes all hardware	EACH	\$ _____
27	Install aluminum gate 36" wide and 8' tall includes all hardware	EACH	\$ _____
28	Install aluminum gate 42" wide and 8' tall, includes all hardware	EACH	\$ _____
29	Install aluminum gate 48" wide and 8' tall, includes all hardware	EACH	\$ _____
30	Install aluminum gate 36" wide and 10' tall includes all hardware	EACH	\$ _____
31	Install aluminum gate 42" wide and 10' tall, includes all hardware	EACH	\$ _____
32	Install aluminum gate 48" wide and 10' tall, includes all hardware handrail per specification	EACH	\$ _____

ITEM No.	ITEM DESCRIPTION	UNIT	UNIT PRICE
RAMP HANDRAILS			
Refers to specifications, Section 5.7, refer to detail 5.7			
33	Ramp handrails, includes all installation	LF	\$ _____
34	Repair damaged ramp handrail per specification	LF	\$ _____
HORSE PARK FENCE			
Refers to specifications, Section 5.8, refer to detail 5.8			
35	Install horse park fence, single row, includes all hardware	LF	\$ _____
36	Install horse park fence, double row, includes all hardware	LF	\$ _____
37	Install single rail, includes hardware	EACH	\$ _____
38	Install single post	EACH	\$ _____
39	Install end or corner post, buried in concrete	EACH	\$ _____
HORSE PARK GATES			
Refers to specifications, Section 5.9, refer to details 5.9a, 5.9b and 5.9c			
40	Install horse park gate 4', includes installation and hardware	EACH	\$ _____
41	Install horse park gate 6', includes installation and hardware	EACH	\$ _____
42	Install horse park gate 8', includes installation and hardware	EACH	\$ _____
43	Install horse park gate 10', I ncludes installation and hardware	EACH	\$ _____
44	Install horse park gate 12', include installation and hardware	EACH	\$ _____
45	Install horse park gate 14', includes installation and hardware	EACH	\$ _____
46	Install horse park gate 16', includes installation and hardware includes installation and hardware	EACH	\$ _____
PEDESTRIAN BOLLARD AND BOLLARDS WITH BLACK CHAIN			
Refers to specifications, Section 5.10, refer to details 5.10a and 5.10b			
47	Bollard with chain, includes installation and all hardware,48"	LFT	\$ _____
48	Pedestrian Bollard, includes install,48"	EACH	\$ _____
49	Bollard with chain, includes installation and all hardware,72"	LFT	\$ _____
50	Pedestrian Bollard, includes install,72"	EACH	\$ _____

51	Chain, includes install	LFT	\$ _____
ITEM No.	ITEM DESCRIPTION	UNIT	UNIT PRICE
SWING GATE LOCKABLE BOLLARD Refers to specifications, Section 5.11, refer to detail 5.11			
52	Install single swing gate lockable bollard, includes installation and hardware, 30"	EACH	\$ _____
53	Install double swing gate lockable bollard, includes installation and hardware, 36"	EACH	\$ _____
54	Install single swing gate lockable bollard, includes installation and hardware, 42"	EACH	\$ _____
55	Install double swing gate lockable bollard, includes installation and hardware, 48"	EACH	\$ _____
56	Install double swing gate lockable bollard, includes installation and hardware, 55"	EACH	\$ _____
SWINGING BARRIER GATES – VEHICULAR TUBULAR GATES, SINGLE AND DOUBLE Refers to specifications, Section 5.12, refer to detail 5.12a and 5.12b			
57	Install single barrier gates, includes installation and hardware, 4' width	EACH	\$ _____
58	Install single barrier gates, includes installation and hardware, 6' width	EACH	\$ _____
59	Install single barrier gates, includes installation and hardware, 8' width	EACH	\$ _____
60	Install single barrier gates, includes installation and hardware, 10' width	EACH	\$ _____
61	Install single barrier gates, includes installation and hardware, 12' width	EACH	\$ _____
62	Install double barrier gates, includes installation and hardware, 4' widths (2)	EACH	\$ _____
63	Install double barrier gates, includes installation and hardware, 6' widths (2)	EACH	\$ _____
64	Install double barrier gates, includes installation and hardware, 8' widths (2)	EACH	\$ _____
65	Install double barrier gates, includes installation and hardware, 10' widths (2)	EACH	\$ _____
66	Install double barrier gates, includes installation and hardware, 12' widths (2)	EACH	\$ _____
VEHICULAR HEAVY DUTY STEEL SINGLE GATES Refer to specifications section 5.13 and detail 5.13			
67	Install vehicular heavy duty steel single gate, includes hardware and installation, 12' wide	EACH	\$ _____
68	Install vehicular heavy duty steel single gate, includes hardware and installation, 14' wide	EACH	\$ _____
69	Install vehicular heavy duty steel single gate, includes hardware and installation, 16' wide	EACH	\$ _____

ITEM No.	ITEM DESCRIPTION	UNIT	UNIT PRICE
70	Install vehicular heavy duty steel single gate, includes hardware and installation, 18' wide	EACH	\$ _____
PEDESTRIAN SECURITY SWING GATES			
Refer to specifications Section 5.14, refer to TYMETAL detail 5.14a and 5.14b			
71	Security swing gate, includes installation and hardware, 42" opening with ornamental fencing	EACH	\$ _____
72	Security swing gate, includes installation and hardware, 48" opening with ornamental fencing	EACH	\$ _____
73	Security swing gate, includes installation and hardware, 60" opening with ornamental fencing	EACH	\$ _____
74	Security swing gate, includes installation and hardware, 71" opening with ornamental fencing	EACH	\$ _____
75	Security swing gate, includes installation and hardware, 42" opening	EACH	\$ _____
76	Security swing gate, includes installation and hardware, 48" opening	EACH	\$ _____
77	Security swing gate, includes installation and hardware, 60" opening	EACH	\$ _____
78	Security swing gate, includes installation and hardware, 71" opening	EACH	\$ _____

ITEM No.	ITEM DESCRIPTION	HEIGHT (FT)	WIDTH (FT)	UNIT	UNIT PRICE (VINYL COAT, 6 GAUGE CORE)	UNIT PRICE (VINYL COAT, 9 GAUGE CORE)	UNIT PRICE (GALVANIZED, 6 GAUGE)	UNIT PRICE (GALVANIZED, 9 GAUGE)
79	Install single gate, includes hardware and posts	4	3	EACH	\$ _____	\$ _____	\$ _____	\$ _____
80	Install single gate, includes hardware and posts	4	4	EACH	\$ _____	\$ _____	\$ _____	\$ _____
81	Install single gate, includes hardware and posts	4	6	EACH	\$ _____	\$ _____	\$ _____	\$ _____
82	Install single gate, includes hardware and posts	4	8	EACH	\$ _____	\$ _____	\$ _____	\$ _____
83	Install single gate, includes hardware and posts	4	10	EACH	\$ _____	\$ _____	\$ _____	\$ _____
84	Install single gate, includes hardware and posts	5	3	EACH	\$ _____	\$ _____	\$ _____	\$ _____
85	Install single gate, includes hardware and posts	5	4	EACH	\$ _____	\$ _____	\$ _____	\$ _____
86	Install single gate, includes hardware and posts	5	6	EACH	\$ _____	\$ _____	\$ _____	\$ _____
87	Install single gate, includes hardware and posts	5	8	EACH	\$ _____	\$ _____	\$ _____	\$ _____

ITEM No.	ITEM DESCRIPTION	HEIGHT (FT)	WIDTH (FT)	UNIT	UNIT PRICE (VINYL COAT, 6 GAUGE CORE)	UNIT PRICE (VINYL COAT, 9 GAUGE CORE)	UNIT PRICE (GALVANIZED, 6 GAUGE)	UNIT PRICE (GALVANIZED, 9 GAUGE)
88	Install single gate, includes hardware and posts	5	10	EACH	\$ _____	\$ _____	\$ _____	\$ _____
89	Install single gate, includes hardware and posts	6	3	EACH	\$ _____	\$ _____	\$ _____	\$ _____
90	Install single gate, includes hardware and posts	6	4	EACH	\$ _____	\$ _____	\$ _____	\$ _____
91	Install single gate, includes hardware and posts	6	6	EACH	\$ _____	\$ _____	\$ _____	\$ _____
92	Install single gate, includes hardware and posts	6	8	EACH	\$ _____	\$ _____	\$ _____	\$ _____
93	Install single gate, includes hardware and posts	6	10	EACH	\$ _____	\$ _____	\$ _____	\$ _____
94	Install single gate, includes hardware and posts	8	3	EACH	\$ _____	\$ _____	\$ _____	\$ _____
95	Install single gate, includes hardware and posts	8	4	EACH	\$ _____	\$ _____	\$ _____	\$ _____
96	Install single gate, includes hardware and posts	8	6	EACH	\$ _____	\$ _____	\$ _____	\$ _____
97	Install single gate, includes hardware and posts	8	8	EACH	\$ _____	\$ _____	\$ _____	\$ _____

ITEM No.	ITEM DESCRIPTION	HEIGHT (FT)	WIDTH (FT)	UNIT	UNIT PRICE (VINYL COAT, 6 GAUGE CORE)	UNIT PRICE (VINYL COAT, 9 GAUGE CORE)	UNIT PRICE (GALVANIZED, 6 GAUGE)	UNIT PRICE (GALVANIZED, 9 GAUGE)
98	Install single gate, includes hardware and posts	8	10	EACH	\$ _____	\$ _____	\$ _____	\$ _____
99	Install single gate, includes hardware and posts	10	3	EACH	\$ _____	\$ _____	\$ _____	\$ _____
100	Install single gate, includes hardware and posts	10	4	EACH	\$ _____	\$ _____	\$ _____	\$ _____
101	Install single gate, includes hardware and posts	10	6	EACH	\$ _____	\$ _____	\$ _____	\$ _____
102	Install single gate, includes hardware and posts	10	8	EACH	\$ _____	\$ _____	\$ _____	\$ _____
103	Install single gate, includes hardware and posts	10	10	EACH	\$ _____	\$ _____	\$ _____	\$ _____
104	Install single gate, includes hardware and posts	12	3	EACH	\$ _____	\$ _____	\$ _____	\$ _____
105	Install single gate, includes hardware and posts	12	4	EACH	\$ _____	\$ _____	\$ _____	\$ _____
106	Install single gate, includes hardware and posts	12	6	EACH	\$ _____	\$ _____	\$ _____	\$ _____
107	Install single gate, includes hardware and posts	12	8	EACH	\$ _____	\$ _____	\$ _____	\$ _____

ITEM No.	ITEM DESCRIPTION	HEIGHT (FT)	WIDTH (FT)	UNIT	UNIT PRICE (VINYL COAT, 6 GAUGE CORE)	UNIT PRICE (VINYL COAT, 9 GAUGE CORE)	UNIT PRICE (GALVANIZED, 6 GAUGE)	UNIT PRICE (GALVANIZED, 9 GAUGE)
108	Install single gate, includes hardware and posts	12	10	EACH	\$ _____	\$ _____	\$ _____	\$ _____
109	Install double gate, includes hardware and posts	4	3	EACH	\$ _____	\$ _____	\$ _____	\$ _____
110	Install double gate, includes hardware and posts	4	4	EACH	\$ _____	\$ _____	\$ _____	\$ _____
111	Install double gate, includes hardware and posts	4	6	EACH	\$ _____	\$ _____	\$ _____	\$ _____
112	Install double gate, includes hardware and posts	4	8	EACH	\$ _____	\$ _____	\$ _____	\$ _____
113	Install double gate, includes hardware and posts	4	10	EACH	\$ _____	\$ _____	\$ _____	\$ _____
114	Install double gate, includes hardware and posts	5	3	EACH	\$ _____	\$ _____	\$ _____	\$ _____
115	Install double gate, includes hardware and posts	5	4	EACH	\$ _____	\$ _____	\$ _____	\$ _____
116	Install double gate, includes hardware and posts	5	6	EACH	\$ _____	\$ _____	\$ _____	\$ _____
117	Install double gate, includes hardware and posts	5	8	EACH	\$ _____	\$ _____	\$ _____	\$ _____

ITEM No.	ITEM DESCRIPTION	HEIGHT (FT)	WIDTH (FT)	UNIT	UNIT PRICE (VINYL COAT, 6 GAUGE CORE)	UNIT PRICE (VINYL COAT, 9 GAUGE CORE)	UNIT PRICE (GALVANIZED, 6 GAUGE)	UNIT PRICE (GALVANIZED, 9 GAUGE)
118	Install double gate, includes hardware and posts	5	10	EACH	\$ _____	\$ _____	\$ _____	\$ _____
119	Install double gate, includes hardware and posts	6	3	EACH	\$ _____	\$ _____	\$ _____	\$ _____
120	Install double gate, includes hardware and posts	6	4	EACH	\$ _____	\$ _____	\$ _____	\$ _____
121	Install double gate, includes hardware and posts	6	6	EACH	\$ _____	\$ _____	\$ _____	\$ _____
122	Install double gate, includes hardware and posts	6	8	EACH	\$ _____	\$ _____	\$ _____	\$ _____
123	Install double gate, includes hardware and posts	6	10	EACH	\$ _____	\$ _____	\$ _____	\$ _____
124	Install double gate, includes hardware and posts	8	3	EACH	\$ _____	\$ _____	\$ _____	\$ _____
125	Install double gate, includes hardware and posts	8	4	EACH	\$ _____	\$ _____	\$ _____	\$ _____
126	Install double gate, includes hardware and posts	8	6	EACH	\$ _____	\$ _____	\$ _____	\$ _____
127	Install double gate, includes hardware and posts	8	8	EACH	\$ _____	\$ _____	\$ _____	\$ _____

ITEM No.	ITEM DESCRIPTION	HEIGHT (FT)	WIDTH (FT)	UNIT	UNIT PRICE (VINYL COAT, 6 GAUGE CORE)	UNIT PRICE (VINYL COAT, 9 GAUGE CORE)	UNIT PRICE (GALVANIZED, 6 GAUGE)	UNIT PRICE (GALVANIZED, 9 GAUGE)
128	Install double gate, includes hardware and posts	8	10	EACH	\$ _____	\$ _____	\$ _____	\$ _____
129	Install double gate, includes hardware and posts	10	3	EACH	\$ _____	\$ _____	\$ _____	\$ _____
130	Install double gate, includes hardware and posts	10	4	EACH	\$ _____	\$ _____	\$ _____	\$ _____
131	Install double gate, includes hardware and posts	10	6	EACH	\$ _____	\$ _____	\$ _____	\$ _____
132	Install double gate, includes hardware and posts	10	8	EACH	\$ _____	\$ _____	\$ _____	\$ _____
133	Install double gate, includes hardware and posts	10	10	EACH	\$ _____	\$ _____	\$ _____	\$ _____
134	Install double gate, includes hardware and posts	12	3	EACH	\$ _____	\$ _____	\$ _____	\$ _____
135	Install double gate, includes hardware and posts	12	4	EACH	\$ _____	\$ _____	\$ _____	\$ _____
136	Install double gate, includes hardware and posts	12	6	EACH	\$ _____	\$ _____	\$ _____	\$ _____
137	Install double gate, includes hardware and posts	12	8	EACH	\$ _____	\$ _____	\$ _____	\$ _____
138	Install double gate, includes hardware and posts	12	10	EACH	\$ _____	\$ _____	\$ _____	\$ _____

LINE ITEM NO.	ITEM DESCRIPTION	UNIT	HEIGHT (FT) 4'	HEIGHT (FT) 6'	HEIGHT (FT) 8'	HEIGHT (FT) 10'	HEIGHT (FT) 12'
BLACK VINYL COATED AND GALVANIZED FENCE (4', 6', 8', 10', 12' HEIGHTS), 2" MESH OPENING Refer to specification Section 5.16							
139	Install fence per specifications, includes material and hardware, vinyl coated, 6 gauge core, top rail and bottom rail	LFT	\$ _____	\$ _____	\$ _____	\$ _____	\$ _____
140	Install fence per specifications, includes material and hardware, vinyl coated, 6 gauge core, bottom rail and tension wire	LFT	\$ _____	\$ _____	\$ _____	\$ _____	\$ _____
141	Install fence per specifications, includes material and hardware, vinyl coated, 6 gauge core, top rail and tension wire	LFT	\$ _____	\$ _____	\$ _____	\$ _____	\$ _____
142	Install fence per specifications, includes material and hardware, vinyl coated, 6 gauge core, top and bottom tension wire	LFT	\$ _____	\$ _____	\$ _____	\$ _____	\$ _____
143	Install fence per specifications, includes material and hardware, galvanized, 6 gauge , top rail and bottom rail	LFT	\$ _____	\$ _____	\$ _____	\$ _____	\$ _____
144	Install fence per specifications, includes material and hardware, galvanized, 6 gauge, bottom rail and tension wire	LFT	\$ _____	\$ _____	\$ _____	\$ _____	\$ _____
145	Install fence per specifications, includes material and hardware, galvanized, 6 gauge top rail and tension wire	LFT	\$ _____	\$ _____	\$ _____	\$ _____	\$ _____

LINE ITEM NO.	ITEM DESCRIPTION	UNIT	HEIGHT (FT) 4'	HEIGHT (FT) 6'	HEIGHT (FT) 8'	HEIGHT (FT) 10'	HEIGHT (FT) 12'
146	Install fence per specifications, includes material and hardware, galvanized, 6 gauge, top and bottom tension wire	LFT	\$ _____	\$ _____	\$ _____	\$ _____	\$ _____
147	Install fence per specifications, includes material and hardware, vinyl coated, 9 gauge core, top rail and bottom rail	LFT	\$ _____	\$ _____	\$ _____	\$ _____	\$ _____
148	Install fence per specifications, includes material and hardware, vinyl coated, 9 gauge core, bottom rail and tension wire	LFT	\$ _____	\$ _____	\$ _____	\$ _____	\$ _____
149	Install fence per specifications, includes material and hardware, vinyl coated, 9 gauge core, top rail and tension wire	LFT	\$ _____	\$ _____	\$ _____	\$ _____	\$ _____
150	Install fence per specifications, includes material and hardware, vinyl coated, 9 gauge core, top and bottom tension wire	LFT	\$ _____	\$ _____	\$ _____	\$ _____	\$ _____
151	Install fence per specifications, includes material and hardware, galvanized, 9 gauge , top rail and bottom rail	LFT	\$ _____	\$ _____	\$ _____	\$ _____	\$ _____
152	Install fence per specifications, includes material and hardware, galvanized, 9 gauge, bottom rail and tension wire	LFT	\$ _____	\$ _____	\$ _____	\$ _____	\$ _____

LINE ITEM NO.	ITEM DESCRIPTION	UNIT	HEIGHT (FT) 4'	HEIGHT (FT) 6'	HEIGHT (FT) 8'	HEIGHT (FT) 10'	HEIGHT (FT) 12'
154	Install fence per specifications, includes material and hardware, galvanized, 9 gauge, top and bottom tension wire	LFT	\$ _____	\$ _____	\$ _____	\$ _____	\$ _____
	LINE ITEM NO.	UNIT	HEIGHT (FT) 4'	HEIGHT (FT) 6'	HEIGHT (FT) 8'	HEIGHT (FT) 10'	HEIGHT (FT) 12'
BLACK VINYL COATED AND GALVANIZED FENCE (8', 10', 12' HEIGHTS), 1 3/4" MESH OPENING							
Refer to specification Section 5.16							
155	Install fence per specifications, includes material and hardware, vinyl coated, 6 gauge core, top rail and bottom rail	LFT	\$ _____	\$ _____	\$ _____	\$ _____	\$ _____
156	Install fence per specifications, includes material and hardware, vinyl coated, 6 gauge core, bottom rail and tension wire	LFT	\$ _____	\$ _____	\$ _____	\$ _____	\$ _____
157	Install fence per specifications, includes material and hardware, vinyl coated, 6 gauge core, top rail and tension wire	LFT	\$ _____	\$ _____	\$ _____	\$ _____	\$ _____
158	Install fence per specifications, includes material and hardware, vinyl coated, 6 gauge core, top and bottom tension wire	LFT	\$ _____	\$ _____	\$ _____	\$ _____	\$ _____

LINE ITEM NO.	ITEM DESCRIPTION	UNIT	HEIGHT (FT) 4'	HEIGHT (FT) 6'	HEIGHT (FT) 8'	HEIGHT (FT) 10'	HEIGHT (FT) 12'
159	Install fence per specifications, includes material and hardware, galvanized, 6 gauge, top rail and bottom rail	LFT	\$ _____	\$ _____	\$ _____	\$ _____	\$ _____
160	Install fence per specifications, includes material and hardware, galvanized, 6 gauge, bottom rail and tension wire	LFT	\$ _____	\$ _____	\$ _____	\$ _____	\$ _____
161	Install fence per specifications, includes material and hardware, galvanized, 6 gauge top rail and tension wire	LFT	\$ _____	\$ _____	\$ _____	\$ _____	\$ _____
162	Install fence per specifications, includes material and hardware, galvanized, 6 gauge, top and bottom tension wire	LFT	\$ _____	\$ _____	\$ _____	\$ _____	\$ _____
163	Install fence per specifications, includes material and hardware, vinyl coated, 9 gauge core, top rail and bottom rail	LFT	\$ _____	\$ _____	\$ _____	\$ _____	\$ _____
164	Install fence per specifications, includes material and hardware, vinyl coated, 9 gauge core, bottom rail and tension wire	LFT	\$ _____	\$ _____	\$ _____	\$ _____	\$ _____
165	Install fence per specifications, includes material and hardware, vinyl coated, 9 gauge core, top rail and tension wire	LFT	\$ _____	\$ _____	\$ _____	\$ _____	\$ _____

LINE ITEM NO.	ITEM DESCRIPTION	UNIT	HEIGHT (FT) 4'	HEIGHT (FT) 6'	HEIGHT (FT) 8'	HEIGHT (FT) 10'	HEIGHT (FT) 12'
166	Install fence per specifications, includes material and hardware, vinyl coated, 9 gauge core, top and bottom tension wire	LFT	\$ _____	\$ _____	\$ _____	\$ _____	\$ _____
167	Install fence per specifications, includes material and hardware, galvanized, 9 gauge, top rail and bottom rail	LFT	\$ _____	\$ _____	\$ _____	\$ _____	\$ _____
168	Install fence per specifications, includes material and hardware, galvanized, 9 gauge, bottom rail and tension wire	LFT	\$ _____	\$ _____	\$ _____	\$ _____	\$ _____
169	Install fence per specifications, includes material and hardware, galvanized, 9 gauge top rail and tension wire	LFT	\$ _____	\$ _____	\$ _____	\$ _____	\$ _____
170	Install fence per specifications, includes material and hardware, galvanized, 9 gauge, top and bottom tension wire	LFT	\$ _____	\$ _____	\$ _____	\$ _____	\$ _____

LINE ITEM NO.	ITEM DESCRIPTION	UNIT	UNIT PRICE					
BACKSTOP								
171	Install backstop, includes all sections per specifications, excludes netting	LFT	\$ _____					
172	Install netting	SQFT	\$ _____					
LINE ITEM NO.	ITEM DESCRIPTION	UNIT	HEIGHT (FT) 4'	HEIGHT (FT) 6'	HEIGHT (FT) 8'	HEIGHT (FT) 10'	HEIGHT (FT) 12'	
FENCE FABRIC								
Refers to specifications, Section 5.18								
173	Fabric 6 gauge, galvanized 2" mesh	LFT	\$ _____	\$ _____	\$ _____	\$ _____	\$ _____	\$ _____
174	Fabric 6 gauge, galvanized 1 3/4" mesh	LFT	\$ _____	\$ _____	\$ _____	\$ _____	\$ _____	\$ _____
175	Fabric 6 gauge, black coated 2" mesh	LFT	\$ _____	\$ _____	\$ _____	\$ _____	\$ _____	\$ _____
176	Fabric 6 gauge, black coated 1 3/4" mesh	LFT	\$ _____	\$ _____	\$ _____	\$ _____	\$ _____	\$ _____
177	Fabric 9 gauge, galvanized 2" mesh	LFT	\$ _____	\$ _____	\$ _____	\$ _____	\$ _____	\$ _____
178	Fabric 9 gauge, galvanized 1 3/4" mesh	LFT	\$ _____	\$ _____	\$ _____	\$ _____	\$ _____	\$ _____
179	Fabric 9 gauge, black coated 2" mesh	LFT	\$ _____	\$ _____	\$ _____	\$ _____	\$ _____	\$ _____
180	Fabric 9 gauge, black coated 1 3/4" mesh	LFT	\$ _____	\$ _____	\$ _____	\$ _____	\$ _____	\$ _____
181	Realign and adjust existing fence, refer to specification section 5.19	LFT	\$ _____	\$ _____	\$ _____	\$ _____	\$ _____	\$ _____
182	Realign fence fabric, refer to specification section 5.20	EACH	\$ _____	\$ _____	\$ _____	\$ _____	\$ _____	\$ _____
183	Realign post, refers to specification section 5.21		\$ _____	\$ _____	\$ _____	\$ _____	\$ _____	\$ _____

ITEM No.	ITEM DESCRIPTION	UNIT	UNIT PRICE
POST AND BRACE Refers to specifications, Section 5.22			
184	Install post 4', 2 1/2" O.D., schedule 40 (black or galvanized)	EACH	\$ _____
185	Install post 6', 2 1/2" O.D., schedule 40 (black or galvanized)	EACH	\$ _____
186	Install post 8', 2 1/2" O.D., schedule 40 (black or galvanized)	EACH	\$ _____
187	Install post 10', 2 1/2" O.D., schedule 40 (black or galvanized)	EACH	\$ _____
188	Install post 12', 2 1/2" O.D., schedule 40 (black or galvanized)	EACH	\$ _____
189	Install post 4', 3" O.D., schedule 40 (black or galvanized)	EACH	\$ _____
190	Install post 6', 3" O.D., schedule 40 (black or galvanized)	EACH	\$ _____
191	Install post 8', 3" O.D., schedule 40 (black or galvanized)	EACH	\$ _____
192	Install post 10', 3" O.D., schedule 40 (black or galvanized)	EACH	\$ _____
193	Install post 12', 3" O.D., schedule 40 schedule 40 (black or galvanized)	EACH	\$ _____
194	Install rail, top, bottom or center rail, 1 5/8" O.D., schedule 40 (black or galvanized)	LFT	\$ _____
195	Remove existing post	EACH	\$ _____

ITEM No.	ITEM DESCRIPTION	UNIT	UNIT PRICE
Refer to Specifications Section 5.23			
196	Tension Bar, 3/4" x 3/16" (galvanized)	EACH	\$ _____
197	Tie Wire, 8 1/2" long, 9 gauge aluminum	LFT	\$ _____
198	Sleeves, 1 5/8" O.D.	EACH	\$ _____
199	Truss Rods, galvanized steel	EACH	\$ _____
200	Boulevard clamps, pressed steel, galvanized	EACH	\$ _____
201	Spring tension, 7 gauge steel, galvanized	EACH	\$ _____
202	Hog rings, 7 gauge steel, galvanized	EACH	\$ _____
203	Hinges, 7 gauge steel, galvanized	EACH	\$ _____
204	Barbed Wire, 2 strands, 14 gauge 0.08" metallic coated core wire, includes support arms	LF	\$ _____
205	Barbed Wire support arms only	EACH	\$ _____
206	Permit cost	EACH	\$ _____
207	Fill Material	CYD	\$ _____

BID ACKNOWLEDGEMENT FORM

I, the undersigned, acknowledge that I have read the Bid Document in its entirety and agree to conform to its every requirement. I further acknowledge that failure to prepare, submit, or execute this bid in the exact manner requested will be just cause to reject my entire bid.

Name of Business Entity Submitting Bid

Print Name and Title of Authorized Signer

Business Entity Street Address

Authorized Signature

Business Entity City, State and Zip Code

Contact Person's Phone Number

Business Entity County

Contact Person's E-mail Address

- Bidder acknowledges addendum(s): No. 1 __, No. 2 __, No. 3 __ (If Applicable) _____ (Initial)
- Bidder acknowledges that this bid is valid for 90 days from and including _____ (Initial)
the bid opening date.
- Bidder acknowledges that bid meets or exceeds minimum specifications. _____ (Initial)
Any deviation from minimum specifications must be explained, in detail,
by bidder as to how the bid does not meet the exact specifications.
- Bidder acknowledgement of Revisions to the above Terms and Conditions:
 - No revisions _____ (Initial)
 - There are revisions and they are included with the bid submittal _____ (Initial)

The above acknowledgment must be properly signed and firmly attached to your bid. The acknowledgment becomes a part of your bid and without it your bid is not be complete and will be subject to rejection.

THIS PAGE MUST BE RETURNED WITH YOUR BID. FAILURE TO SUBMIT THIS COMPLETED FORM WILL RESULT IN YOUR BID BEING DEEMED NON-RESPONSIVE.

ATTACHMENT A

REQUIRED DOCUMENTS CHECKLIST

Bidder shall complete and submit the following documents with their bid:

Bid Page No.	Title	Check This Box If Included With Bid
66	Bid Acknowledgement Form*	
67	Required Documents Checklist	
68	Contractor Reference and Release Form*	
69	Subcontractor Reference and Release Form, if applicable**	
71	Contractor Affidavit*	
72	Subcontractor Affidavit, if applicable**	
73-81	LSBE - Exhibits A and/or B of Attachment G*	
83	New Employee Tracking Form*	
84	First Source Jobs Acknowledgement Form *	

Include this if applicable Bidder shall also submit a **copy** of the following required documents with the bid:

-	Business License*	
---	-------------------	--

***If these mandatory forms are not completed and submitted with the bid, the bidder will be deemed non-responsive.**

****These forms are applicable if a subcontractor will be utilized to fulfill the requirements of this contract. If these forms are applicable, they must be completed and submitted along with the bid. Failure to submit these forms, if applicable, will result in the bidder being deemed non-responsive.**

I, the undersigned, acknowledge that I have included the requested documents as listed above.

Printed Name

Signature

ATTACHMENT B

CONTRACTOR REFERENCE AND RELEASE FORM

List below at least three (3) references, including company name, contact name, address, email address, telephone numbers and contract period who can verify your experience and ability to perform the type(s) of product(s)/ service(s) listed in the solicitation.

Company Name	Contract Period		
Contact Person Name and Title	Telephone Number (include area code)		
Complete Primary Address	City	State	Zip Code
Email Address	Fax Number (include area code)		
Project Name and Description			

Company Name	Contract Period		
Contact Person Name and Title	Telephone Number (include area code)		
Complete Primary Address	City	State	Zip Code
Email Address	Fax Number (include area code)		
Project Name and Description			

Company Name	Contract Period		
Contact Person Name and Title	Telephone Number (include area code)		
Complete Primary Address	City	State	Zip Code
Email Address	Fax Number (include area code)		
Project Name and Description			

REFERENCE CHECK RELEASE STATEMENT

You are authorized to contact the references provided above for purposes of this ITB.

Signed _____ Title _____
(Authorized Signature of Bidder)

Company Name _____ Date _____

ATTACHMENT C

SUBCONTRACTOR REFERENCE AND RELEASE FORM

List below at least three (3) references, including company name, contact name, address, email address, telephone numbers and contract period who can verify your experience and ability to perform the type(s) of product(s)/ service(s) listed in the solicitation.

Company Name	Contract Period		
Contact Person Name and Title	Telephone Number (include area code)		
Complete Primary Address	City	State	Zip Code
Email Address	Fax Number (include area code)		
Project Name and Description			

Company Name	Contract Period		
Contact Person Name and Title	Telephone Number (include area code)		
Complete Primary Address	City	State	Zip Code
Email Address	Fax Number (include area code)		
Project Name and Description			

Company Name	Contract Period		
Contact Person Name and Title	Telephone Number (include area code)		
Complete Primary Address	City	State	Zip Code
Email Address	Fax Number (include area code)		
Project Name and Description			

REFERENCE CHECK RELEASE STATEMENT

You are authorized to contact the references provided above for purposes of this ITB.

Signed _____ Title _____
(Authorized Signature of Bidder)

Company Name _____ Date _____

ATTACHMENT D

CONTRACTOR & SUBCONTRACTOR EVIDENCE OF COMPLIANCE:

- (1) County contracts for the physical performance of services within the state of Georgia shall include the following provisions:¹
 - a. the contractor has registered with and is authorized to use the federal work authorization program to verify information on all newly hired employees or subcontractors;
 - b. by affidavit, the contractor must attest to the contractor's name, address, user identification number, date of authorization, and verification of the continual participation throughout the contract period, and
 - c. the affidavit shall become a part of the covered contract and must be attached.
- (2) No contractor or subcontractor who enters into a contract with the County shall enter into such a contract or subcontract in connection with the physical performance of services within Georgia unless the contractor or subcontractor registers and participates in the federal work authorization program to verify information of all newly hired employees. Any employee, contractor, or subcontractor of such contractor or subcontractor shall also be required to satisfy the requirements of O.C.G.A. § 13-10-91, as amended.
- (3) Upon contracting with a new subcontractor, a contractor or subcontractor shall, as a condition of any contract or subcontract entered into pursuant to O.C.G.A. § 13-10-91, as amended, agree to provide the County with notice of the identity of any and all subsequent subcontractors hired or contracted by the contractor or subcontractor. Such notice shall be provided within five (5) business days of entering into a contract or agreement for hire with any subcontractor. Such notice shall include an affidavit from each subsequent contractor attesting to the subcontractor's name, address, user identification number, and date of authorization to use the federal work authorization program.
- (4) An affidavit shall be considered an open public record; provided, however, that any information protected from public disclosure by federal law or by Article 4 of Chapter 28 of Title 50 shall be redacted. Affidavits shall be maintained by the County for five years from the date of receipt.
- (5) To verify compliance, the contractor agrees to participate in random audits conducted by the Commissioner of the Georgia Department of Labor. The results of the audits shall be published on the www.open.georgia.gov website, and on the Department of Labor's website no later than December 31 of each year.
- (6) Any person who knowingly and willfully makes a false, fictitious, or fraudulent statement in an affidavit submitted pursuant to O.C.G.A. § 13-10-91 shall be guilty of a violation of Code § 16-10-20 and, upon conviction, shall be punished as provided in such section. Contractors and subcontractors convicted for false statements based on a violation of such section shall be prohibited from bidding on or entering into any public contract for twelve (12) months following such conviction.

¹ O.C.G.A. § 13-10-91, as amended

ATTACHMENT E

CONTRACTOR AFFIDAVIT

By executing this affidavit, the undersigned verifies its compliance with O.C.G.A. § 13-10-91, as amended, stating affirmatively that the individual, firm or corporation which is contracting with DEKALB COUNTY, GA, a political subdivision of the State of Georgia, has registered with and is participating in a federal work authorization program* [any of the electronic verification of work authorization programs operated by the United States Department of Homeland Security or any equivalent federal work authorization program operated by the United States Department of Homeland Security to verify information of newly hired employees, pursuant to the Immigration Reform and Control Act of 1986 (IRCA), P.L. 99-603, in accordance with the applicability provisions and deadlines established in O.C.G.A. § 13-10-91, as amended]. The affiant agrees to continue to use the federal work authorization program throughout the contract period.

The undersigned further agrees that, should it employ or contract with any subcontractor(s) in connection with the physical performance of services pursuant to this contract with the COUNTY, contractor will secure from such subcontractor(s) similar verification of compliance with O.C.G.A. § 13-10-91, as amended, on the Subcontractor Affidavit form. Contractor further agrees to maintain records of such compliance and provide a copy of each such verification to the COUNTY, within five (5) days from when the subcontractor(s) is retained to perform such service.

BY: Authorized Officer or Agent
(Bidder's Name)

Federal Work Authorization
Enrollment Date

Title of Authorized Officer or Agent of Bidder

Identification Number

Printed Name of Authorized Officer or Agent

Address (* do not include a post office box)

SUBSCRIBED AND SWORN
BEFORE ME ON THIS THE

_____ DAY OF _____, 20__

Notary Public

My Commission Expires: _____

ATTACHMENT F

SUBCONTRACTOR AFFIDAVIT

By executing this affidavit, the undersigned verifies its compliance with O.C.G.A. § 13-10-91, as amended, stating affirmatively that the individual, firm, or corporation which is engaged in the physical performance of services under a contract with _____ name of contractor) on behalf of DEKALB COUNTY, GA, a political subdivision of the State of Georgia, has registered with and is participating in a federal work authorization program* [any of the electronic verification of work authorization programs operated by the United States Department of Homeland Security or any equivalent federal work authorization program operated by the United States Department of Homeland Security to verify information of newly hired employees, pursuant to the Immigration Reform and Control Act of 1986 (IRCA), P.L. 99-603, in accordance with the applicability provisions and deadlines established in O.C.G.A. § 13-10-91, as amended]. The affiant agrees to continue to use the federal work authorization program throughout the contract period.]

BY: Authorized
Work Authorization
(Bidder's Name)

Officer or Agent Federal

Enrollment Date

Title of Authorized Officer or Agent of Bidder Identification

Number

Printed Name of Authorized Officer or Agent

Address (* do not include a post office box)

SUBSCRIBED AND SWORN
BEFORE ME ON THIS THE

_____ DAY OF _____, 20__

Notary Public

My Commission Expires: _____

ATTACHMENT G

**DEKALB FIRST LSBE INFORMATION
WITH EXHIBITS A – B**

**SCHEDULE OF LOCAL SMALL BUSINESS ENTERPRISE PARTICIPATION
OPPORTUNITY TRACKING FORM**

The Chief Executive Officer and the Board of Commissioners of DeKalb County believe that it is important to encourage the participation of small and local businesses in the continuing business of County government; and that the participation of these types of businesses in procurement will strengthen the overall economic fabric of DeKalb County, contribute to the County's economy and tax base, and provide employment to local residents. Therefore, the Chief Executive Officer and the Board of Commissioners have made the success of local small businesses a permanent goal of DeKalb County by implementing the DeKalb First Local Small Business Enterprise Ordinance.

**PROVISIONS OF DEKALB FIRST LOCAL SMALL BUSINESS ENTERPRISE (LSBE)
ORDINANCE**

Percentage of LSBE Participation Required
20% of Total Award

Certification Designation	Request For Proposals (RFP)
LSBE Within DeKalb (LSBE-DeKalb)	Ten (10) Preference Points
LSBE Outside DeKalb (LSBE-MSA)	Five (5) Preference Points
Demonstrated GFE	Two (2) Preference Points

Certified Local Small Business Enterprises (LSBEs) located within DeKalb County and prime contractors utilizing LSBEs that are locally-based inside DeKalb County shall receive ten (10) points in the initial evaluation of their response to any Request for Proposal. Certified LSBEs located outside of DeKalb County but within the nine (9) County Metropolitan Statistical Area (MSA) consisting of Cherokee, Clayton, Cobb, Douglas, Fayette, Fulton, Gwinnett, Henry and Rockdale Counties shall receive five (5) points in the initial evaluation of their response to any Request for Proposal. Prime Contractors who demonstrate sufficient good faith efforts in accordance with the requirements of the ordinance shall be granted two (2) points in their initial evaluation of responses to any Request for Proposal. Pro-rated points shall be granted where a mixture of LSBE-DeKalb and LSBE MSA firms are utilized. Utilization of each firm shall be based upon the terms of the qualified sealed solicitation.

Prime Contractor(s) deemed responsible and remains responsive to an Invitation to Bid (ITB) because they are either a certified LSBE-DeKalb or LSBE-MSA firm or has obtained 20% participation of an LSBE-DeKalb or LSBE-MSA firm, submits the lowest bid price shall be deemed the lowest, responsive and responsible bidder.

Prime Contractor(s) deemed responsible and remains responsive to an Invitation to Bid (ITB) and documented good faith efforts, submits a lower bid price than a Prime Contractor that achieved 20% LSBE participation, or otherwise required benchmark, then the Prime Contractor who actually met the benchmark will be given the opportunity to match the lowest bid price of the Prime Contractor who only made good faith efforts. Prime Contractor(s) who choose **not** to match the lowest bid price, then the Prime Contractor who made the good faith efforts will be deemed the lowest, responsive and responsible bidder.

For all qualified sealed solicitations, the Director of Purchasing and Contracting, DeKalb County Government, shall determine if the bidder/proposer has included written documentation showing that at least twenty percent (20%) of the total contract award will be performed by a certified LSBE. This written documentation shall be in the form of a notarized Schedule of LSBE Participation (Attached hereto as "Exhibit A".) For all contracts, a signed letter of intent from all certified LSBEs describing the work, material, equipment and/or services to be performed or provided by the LSBE(s) and the agreed upon percentage shall be due with the bid or proposal documents and included with "Exhibit A". The certified vendor list establishes the group of Certified LSBE's from which the bidder/proposer must solicit subcontractors for LSBE participation. This list can be found on our website <https://www.dekalbcountyga.gov/purchasing> or obtained from the Special Projects LSBE Program team.

Prime Contractors failing to meet the LSBE benchmark must document and demonstrate Good Faith Efforts in accordance with the attached "Checklist for Good Faith Efforts" portion of "Exhibit A." The notarized Schedule of LSBE Participation shall be due and submitted with each bid or proposal. Failure to achieve the LSBE benchmark or demonstrate good faith efforts shall result in a bid or proposal being rejected. Prime Contractors that fail to attend the mandatory LSBE meeting in person or via video conference shall mean that the Prime Contractor has not demonstrated sufficient good faith efforts and its bid or proposal if submitted, shall be deemed non-responsive without any further review.

Upon award, Prime Contractors are required to submit a report detailing LSBE Sub-Contractor usage with each request for payment and not less than on a monthly basis. Prime Contractors shall ensure that all LSBE sub-contractors have been paid within seven (7) days of the Prime's receipt of payment from the County. Failure to provide requested reports/documentation shall constitute a material breach of contract, entitling the County to terminate the Contract for default or pursue other remedies. LSBE sub-contractors must confirm payments received from the Prime(s) for each County contract they participate in.

For eligible bids/proposals valued over \$5,000,000.00, the Mentor-Protégé provision of the Ordinance shall apply. Prime Contractors must agree to become mentors and take on an LSBE protégé in an effort to enhance the potential of future LSBEs. Qualifying projects shall be performed by both Mentor and Protégé through a subcontract between both parties. This requirement is in addition to all other applicable sections of the DeKalb First Ordinance. Please review the ordinance, section 2-214 or contact the LSBE Program Representative for detailed information regarding this initiative.

EXHIBIT A

**SCHEDULE OF DEKALB FIRST LOCAL SMALL BUSINESS ENTERPRISE PARTICIPATION
OPPORTUNITY TRACKING FORM**

As specified, Bidders and Proposers are to present the details of LSBE participation below:

PRIME BIDDER/PROPOSER _____

SOLICITATION NUMBER: 19-101137

TITLE OF UNIT OF WORK – Fence Installation and Repairs

1. My firm, as the prime bidder/proposer on this unit of work, is a certified (check all that apply):
 ___ LSBE-DeKalb ___ LSBE-MSA

2. If you are a Certified LSBE-DeKalb or MSA, please indicate below the percentage of that your firm will carry out directly: _____.

3. If the prime bidder/proposer is a joint venture, please describe below the nature of the joint venture and level of work and percentage of participation to be provided by the LSBE-DeKalb or MSA joint venture firm.

4. List the LSBE-DeKalb or MSA subcontractors and/or firms (including suppliers) to be utilized in of this contract, if awarded. No changes can be made in the subcontractors listed below without the prior written approval of the County. Please attach a signed letter of intent from all certified LSBEs describing the work, materials, equipment or services to be performed and/or provided and the agreed upon percentage of work to be performed. A Letter of Intent form is attached hereto as "Exhibit B".

Name of Company	
Address	
Telephone	
Fax	
Contact Person	
Indicate certification status and attach proof of certification: LSBE-DeKalb/LSBE-MSA	
Description of services to be performed	
Percentage of work to be performed	

Name of Company	
Address	
Telephone	
Fax	
Contact Person	
Indicate certification status and attach proof of certification: LSBE-DeKalb/LSBE-MSA	
Description of services to be performed	
Percentage of work to be performed	

Name of Company	
Address	
Telephone	
Fax	
Contact Person	
Indicate certification status and attach proof of certification: LSBE-DeKalb/LSBE-MSA	
Description of services to be performed	
Percentage of work to be performed	

Name of Company	
Address	
Telephone	
Fax	
Contact Person	
Indicate certification status and attach proof of certification: LSBE-DeKalb/LSBE-MSA	
Description of services to be performed	
Percentage of work to be performed	

Name of Company	
Address	
Telephone	
Fax	
Contact Person	
Indicate certification status and attach proof of certification: LSBE-DeKalb/LSBE-MSA	
Description of services to be performed	
Percentage of work to be performed	

Please attach additional pages, if necessary.

EXHIBIT A, CONT'D
DEKALB COUNTY
CHECKLIST FOR GOOD FAITH EFFORTS

A bidder/proposer that does not meet the County's LSBE participation benchmark is required to submit documentation to support all "Yes" responses as proof of "good faith efforts." Please indicate whether or not any of these actions were taken:

	Yes	No	Description of Actions
1.			Prime Contractors shall attend a MANDATORY LSBE Meeting in person or via video conference within two-weeks of advertisement of the solicitation.
2.			Provide a contact log showing the company's name, contact person, address, email and contact number (phone or fax) used to contact the proposed certified subcontractors, nature of work requested for quote, date of contact, the name and title of the person making the effort, response date and the percentage of work.
3.			Provide interested LSBEs via email, of any new relevant information, if any, at least 5 business days prior to submission of the bid or proposal.
4.			Efforts made to divide the work for LSBE subcontracting areas likely to be successful and to identify portions of work available to LSBEs consistent with their availability. Include a list of divisions of work not subcontracted and the corresponding reasons for not including them. The ability or desire of a bidder/proposer to perform the contract work with its own organization does not relieve it of the responsibility to make good faith efforts on all scopes of work subject to subcontracting.
5.			Efforts were made to assist potential LSBE subcontractors meet bonding, insurance, or other governmental contracting requirements. Where feasible, facilitating the leasing of supplies or equipment when they are of such a specialized nature that the LSBE could not readily and economically obtain them in the marketplace.
6.			Communication via email or phone with DeKalb First Program Staff seeking assistance in identifying available LSBEs. Provide DeKalb First Program Staff representative name and title, and date of contact.
7.			For all contracts, a signed letter of intent from all certified LSBEs describing the work, materials, equipment or services to be performed or provided by the LSBE(s) and the agreed upon LSBE participation percentage shall be due with the bid or proposal documents.
8.			Other Actions, to include Mentor/Protégé commitment for solicitations \$5M and above (specify):

Please explain all "no" answers above (by number):

This list is a guideline and by no means exhaustive. The County will review these efforts, along with attached supporting documents, to assess the bidder/proposer's efforts to meet the County's LSBE Participation benchmark. If you require assistance in identifying certified, bona fide LSBEs, please contact the Purchasing and Contracting Department - DeKalb First Program, Felton Williams, Procurement Projects Manager at 404-371-6312.

EXHIBIT A, CONT'D

**DEKALB FIRST LOCAL SMALL BUSINESS ENTERPRISE SCHEDULE OF
PARTICIPATION
OPPORTUNITY TRACKING FORM**

Bidder/Proposer Statement of Compliance

Bidder(s)/Proposer(s) hereby state that they have read and understand the requirements and conditions as set forth in the objectives and that reasonable effort were made to support the County in providing the maximum practicable opportunity for the utilization of LSBEs consistent with the efficient and economical performance of this contract. The Bidder and any subcontractors shall file compliance reports at reasonable times and intervals with the County in the form and to the extent prescribed by the Director of DeKalb County Purchasing and Purchasing and Contracting Department. Compliance reports filed at such times as directed shall contain information as to the employment practices, policies, programs and statistics of Contractors and their subcontractors.

1. Non-Discrimination Policy

- a. During the performance of this agreement, Contractor agrees to conform to the following Non-Discrimination Policy adopted by the County.
- b. Contractor shall not discriminate against any employee or applicant for employment because of race, color, religion, sex, national origin, or disability. The Contractor will take action to ensure that applicants are employed, and the employees are treated during employment without regard to their race, color, religion, sex, national origin, or disability. Such action shall include, but not be limited to, the following:
 - (1) Employment, upgrading, demotion or transfer; recruitment or recruitment advertising; layoff or termination; rates of pay or other forms of compensation; and selection for training, including apprenticeship. Contractor agrees to post in conspicuous places available to employees and applicants for employment, notices to be provided setting forth provisions of this non-discrimination clause.
 - (2) Contractor shall, in all solicitations or advertisements for employees placed by or on behalf of Contractor, state that all qualified applicants will receive consideration for employment without regard to race, color, religion, sex, national origin, or disability.
- c. Without limiting the foregoing, Contractor shall not discriminate on the basis of disability in the admission or access to, or treatment or employment in, the programs and activities, which form the subject of the contract. The Contractor will take action to ensure that applicants for participation in such programs and activities are considered without regard to disability. Such action shall include, but not be limited to, the following:
 - (1) Contractor agrees to post in conspicuous places available to participants in its programs and activities notices to be provided setting forth the provisions of this non-discrimination clause.
 - (2) Contractor shall, in all solicitations or advertisements for programs or activities, which are the subject of the contract, state that all qualified applicants will receive consideration for participation without regard to disability.

2. Commitment

The undersigned certifies that he/she has read, understands, and agrees to be bound by the bid specifications, including the accompanying Exhibits and other terms and conditions of the Invitation to Bid and/or Request for Proposal regarding LSBE utilization. The undersigned further certifies that he/she is legally authorized by the bidder or responder to make the

statements and representations in Exhibit A and that said statements and representations are true and correct to the best of his/her knowledge and belief. The undersigned will enter into formal agreement(s) with the LSBE(s) listed in this Exhibit A, which are deemed by the owner to be legitimate and responsible LSBEs. Said agreement(s) shall be for the work and contract with the Prime Contractor. The undersigned understands and agrees that if any of the statements and representations are made by the Bidder knowing them to be false, or if there is a failure of the successful Bidder (i.e., Contractor) to implement any of the stated agreements, intentions, objectives, goals and commitments set forth herein without prior approval of the County, then in any such events the contractor's act or failure to act, as the case may be, shall constitute a material breach of contract, entitling the County to terminate the Contract for default. The right to so terminate shall be in addition to, and not in lieu of, any other rights and remedies the County may have for other defaults under the Contract. Additionally, the Contractor will be subject to the loss of any future contract awards by the County for a period of one year.

Firm Name (Please Print):

Firm's Officer:

(Authorized Signature and Title Required)

Date

Sworn to and Subscribed to before me this ____ day of _____, 201__.

Notary Public

My Commission Expires: _____

EXHIBIT B

**LETTER OF INTENT TO PERFORM AS A SUBCONTRACTOR
PROVIDING MATERIALS OR SERVICES**

Instructions:

1. Complete the form in its entirety and submit with bid documents.
2. Attach a copy of the LSBE's current valid Certification Letter.

To: _____
(Name of Prime Contractor Firm)

From: _____ **LSBE -DeKalb** **LSBE -MSA**
(Name of Subcontractor Firm) (Check all that apply)

ITB Number: 19-101137

Project Name: Fence Installation and Repairs

The undersigned subcontractor is prepared to perform the following described work or provide materials or services in connection with the above project (specify in detail particular work items, materials, or services to be performed or provided).

Description of Materials or Services	Project/Task Assignment	% of Contract Award

Prime Contractor

Sub-contractor

Signature: _____

Signature: _____

Title: _____

Title: _____

Date: _____

Date: _____



FIRST SOURCE JOBS ORDINANCE
INFORMATION (WITH EXHIBITS 1 – 4)

EXHIBIT 1

FIRST SOURCE JOBS ORDINANCE ACKNOWLEDGEMENT

The DeKalb County First Source Ordinance requires contractors or beneficiaries of eligible projects entering into any type of agreement with the County, including purchase orders, regardless of what they may be called, for the procurement or disposal of supplies, services, construction projects, professional or consultant services, which is funded in whole or part with County funds or County administered funds in which the contractor is to receive \$50,000 or more in County expenditures or committed expenditures and recipient of urban redevelopment action grants or community development block funds administered in the amount of \$50,000 or more to make a good faith effort to hire DeKalb County residents for at least 50% of jobs created using the First Source Registry (candidate database) within one hundred twenty (120) days of contract execution. The work to be performed under this contract is subject to the provisions of the DeKalb County First Source Jobs Ordinance. All contractors will be asked to submit an Employment Roster and/or copies of active payroll registers on a monthly basis to verify compliance. The undersigned acknowledges and agrees to comply with the provisions of the DeKalb County First Source Jobs Ordinance.

CONTRACTOR OR BENEFICIARY INFORMATION:

Contractor or Beneficiary Name (Signature)

Contractor or Beneficiary Name (Printed)

Title

Telephone

Email

Name of Business

Please answer the following questions:

1. How many job openings do you anticipate filling related to this contract? _____
2. How many incumbents/existing employees will retain jobs due to this contract?
DeKalb Residents: _____ Non-DeKalb Residents: _____
3. How many work hours per week constitutes Full Time employment? _____

Please return this form to WorkSource DeKalb, (404)687-3900 or email to fkadkins@dekalbcountyga.gov, malee@dekalbcountyga.gov, vlricksion@dekalbcountyga.gov, or jmjonas@dekalbcountyga.gov

WorkSource DeKalb (WSD) is an EEO/M/F/D/V employer/program. Auxiliary aids/services are available upon request to individuals with disabilities. Persons with hearing impairments may call 1-800-255-0135 or 711 TTY for assistance. WSD is 100% funded by the U. S. Department of Labor and is a proud partner of the American Job Center Network. Revised March 2018



FIRST SOURCE JOBS ORDINANCE
INFORMATION
EXHIBIT 2

NEW EMPLOYEE TRACKING FORM

Name of Bidder _____

Address _____

E-Mail _____

Phone Number _____

Fax Number _____

Do you anticipate hiring from the First Source Candidate Registry? Y or N (Circle one)

If so, the approximate number of employees you anticipate hiring: _____

Type of Position (s) you anticipate hiring: (List position title, one position per line) Attach job description per job title:	The number you anticipate hiring:	Timeline

Please return this form to WorkSource DeKalb, fax (404) 687-4099 or email to FirstSourceJobs@dekalbcountyga.gov.

**FIRST SOURCE JOBS ORDINANCE INFORMATION
EXHIBIT 3**

BUSINESS SERVICE REQUEST FORM

Please note: We need one form completed for each position that you have available.

DATE: _____ FEDERAL TAX ID: _____

COMPANY NAME: _____ WEBSITE: _____

ADDRESS: _____

(WORKSITE ADDRESS IF DIFFERENT): _____

CONTACT NAME: _____

CONTACT PHONE: _____ CONTACT FAX: _____

CONTACT E-MAIL ADDRESS: _____

Are you a private employment agency or staffing agency? YES NO

JOB DESCRIPTION: (PLEASE INCLUDE A COPY OF JOB DESCRIPTION)

POSITION TITLE: _____

NUMBER OF POSITIONS AVAILABLE: _____ TARGET START DATE: _____

WEEKLY WORK HOURS: 20-30 hours 30-40 hours Other

SPECIFIC WORK SCHEDULE:

SALARY RATE(OR RANGE):

PERM TEMP TEMP-TO-PERM SEASONAL

PUBLIC TRANSPORTATION ACCESSIBILITY YES NO

IF SCREENINGS ARE REQUIRED, SELECT ALL THAT APPLY:

CREDIT DRUG MVR BACKGROUND OTHER

Please return form to: Business Solutions Unit (First Source)

774 Jordan Lane Bldg. #4

Decatur, Ga. 30033

Phone: (404) 687-3400

FirstSourceJobs@dekalbcountyga.gov

**FIRST SOURCE JOBS ORDINANCE INFORMATION
EXHIBIT 4**

**EMPLOYMENT ROSTER
DeKalb County**

Contract Number: _____
Project Name: _____
Contractor: _____ Date: _____

Name	Position:	Start Date	Hourly Rate of Pay	Hired for this Project? (yes/no)	Anticipated Length of Employment (Months)	% of Time Dedicated to the Project	Full or Part Time? (No. of Hours)	Georgia County of Residency

Attachment H Drawings

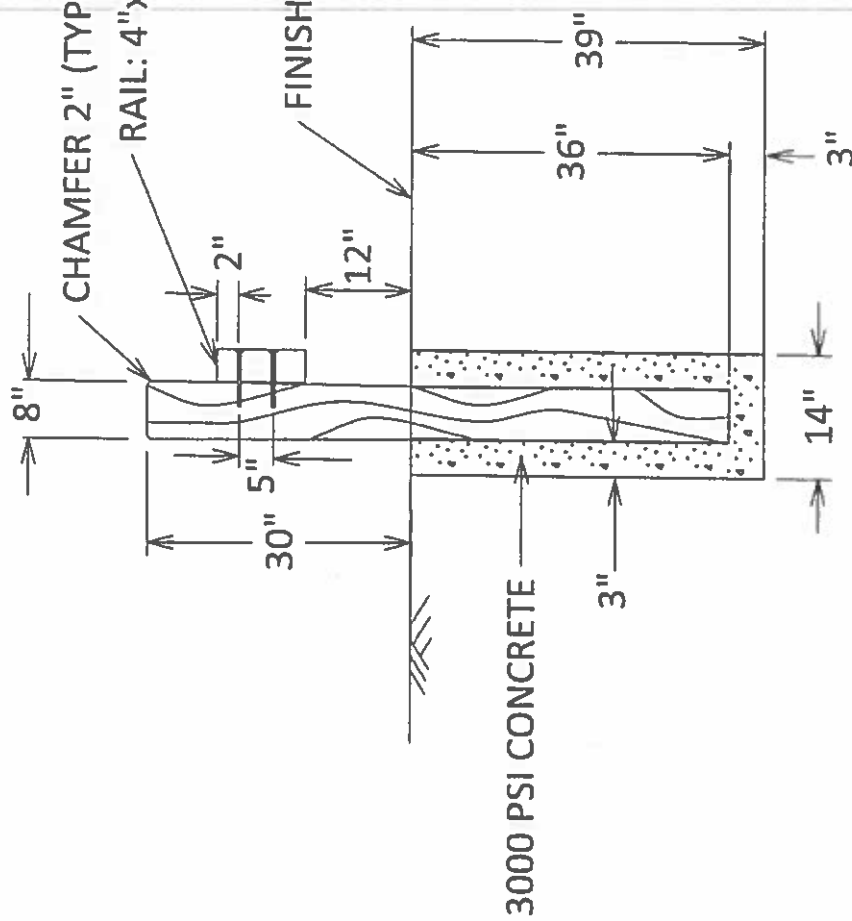

SECTION

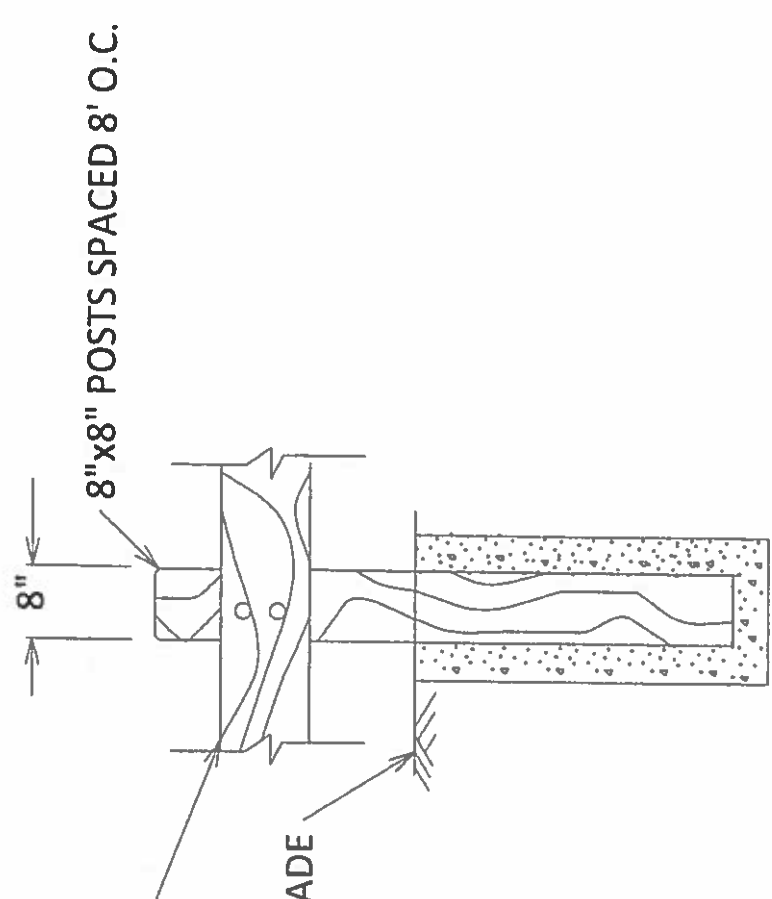

ELEVATION

WOODEN GUARDRAIL
NTS

DETAIL 5.2

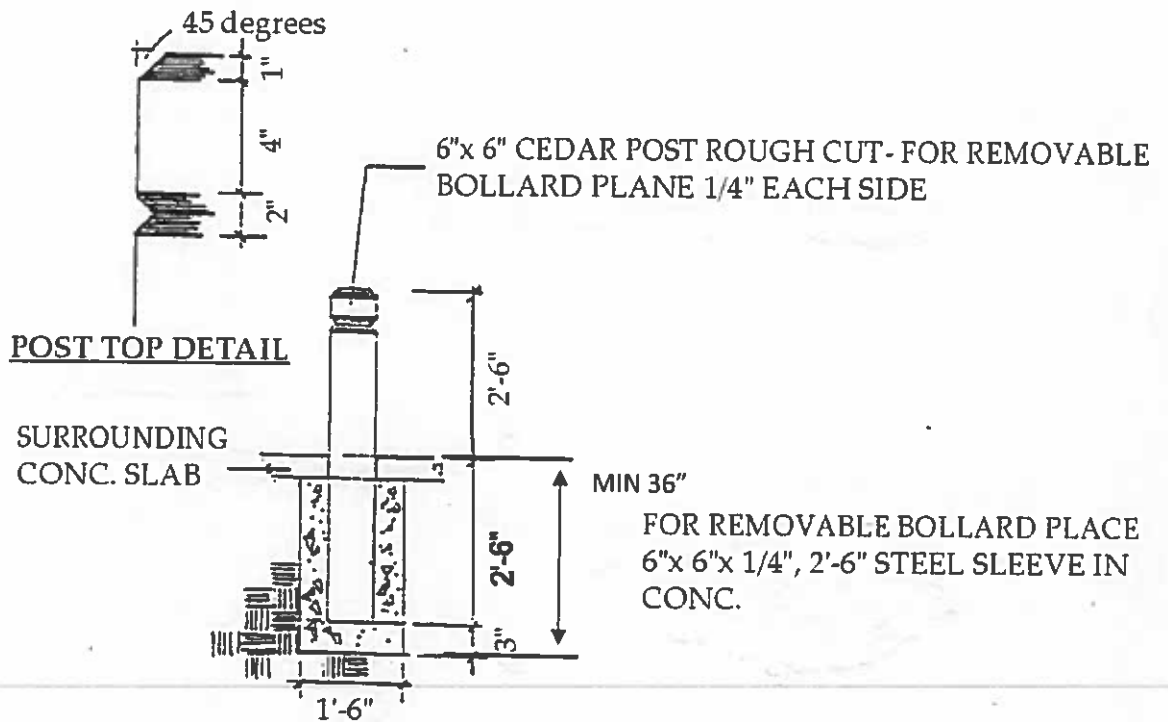

- Locking bollards will have a hole through the base with 1/2 inch rebar inserted. Rebar will be bent with a hole for a lock to be attached.
- Removable bollards should have locking mechanism.

WOOD BOLLARD

NTS

Detail 5.3

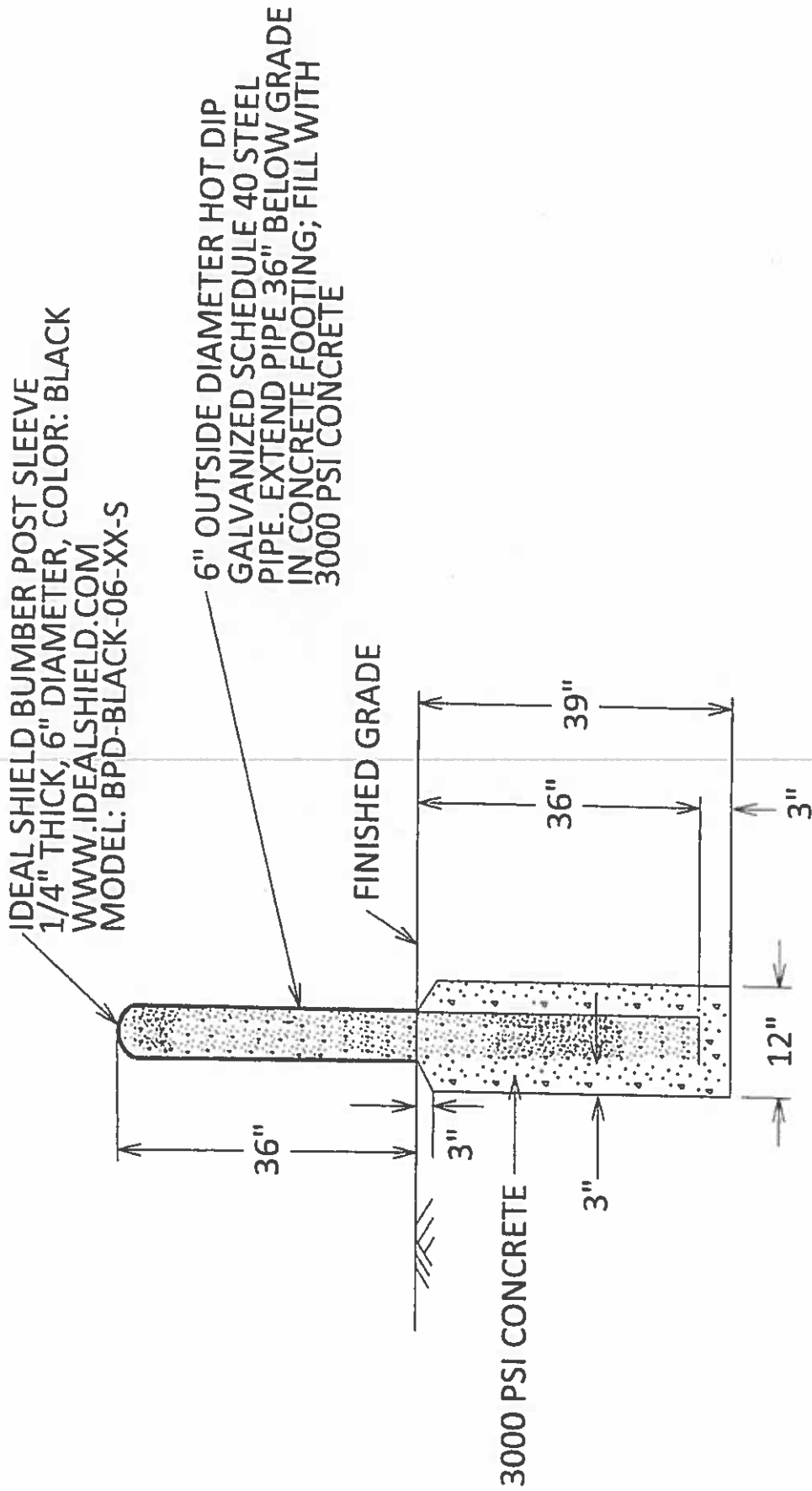

(1/4") 6" Bollard Cover Product Specifications

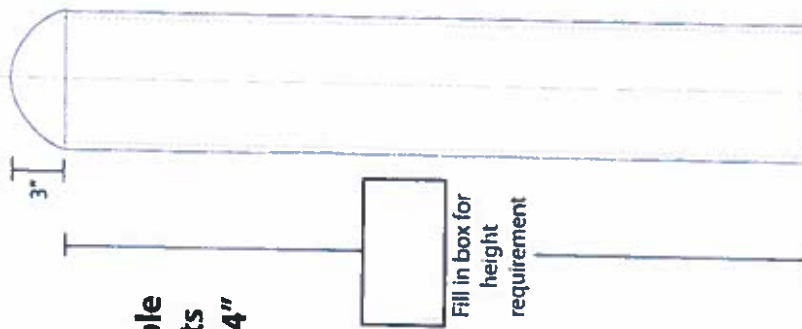

Available Heights Up to 84"

Steel Pipe ID = 6"
 Steel Pipe OD = 6.625"
 Circumference = 20.5" - 21.5"
 Ideal Sleeve ID = 6 7/8"

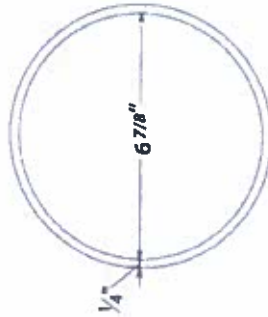

Cross Section of Sleeve

Color: _____
 Standard Colors: Yellow, Red, Black, Blue, Brown, Gray, Green, Orange, & White

Custom Color: Pantone®/Sherwin Williams® # _____
 (if applicable)

Quantity: _____

Name: _____

Address: _____

City, State, Zip: _____

Phone: _____

Email: _____

**Bollard Cover height may change shipping costs associated.

Please fax or email your product inquiry to fax #: (313) 842-7860 or info@idealsshield.com

THESE DRAWING AND ALL THE INFORMATION HEREON IS THE PROPERTY OF IDEALSHIELD. NO PART OF THIS DRAWING OR INFORMATION IS TO BE REPRODUCED OR TRANSMITTED IN ANY FORM OR BY ANY MEANS, ELECTRONIC OR MECHANICAL, INCLUDING PHOTOCOPYING, RECORDING, OR BY ANY INFORMATION STORAGE AND RETRIEVAL SYSTEM.		ORDER NO. _____ QUANTITY _____ DESCRIPTION (1/4") 6" Bollard Cover	
IDEALSHIELD 2525 Clark St. Detroit, MI 48207		DATE _____ BY _____ CHECKED BY _____ APPROVED BY _____	

www.idealsshield.com | (866) 825-8659

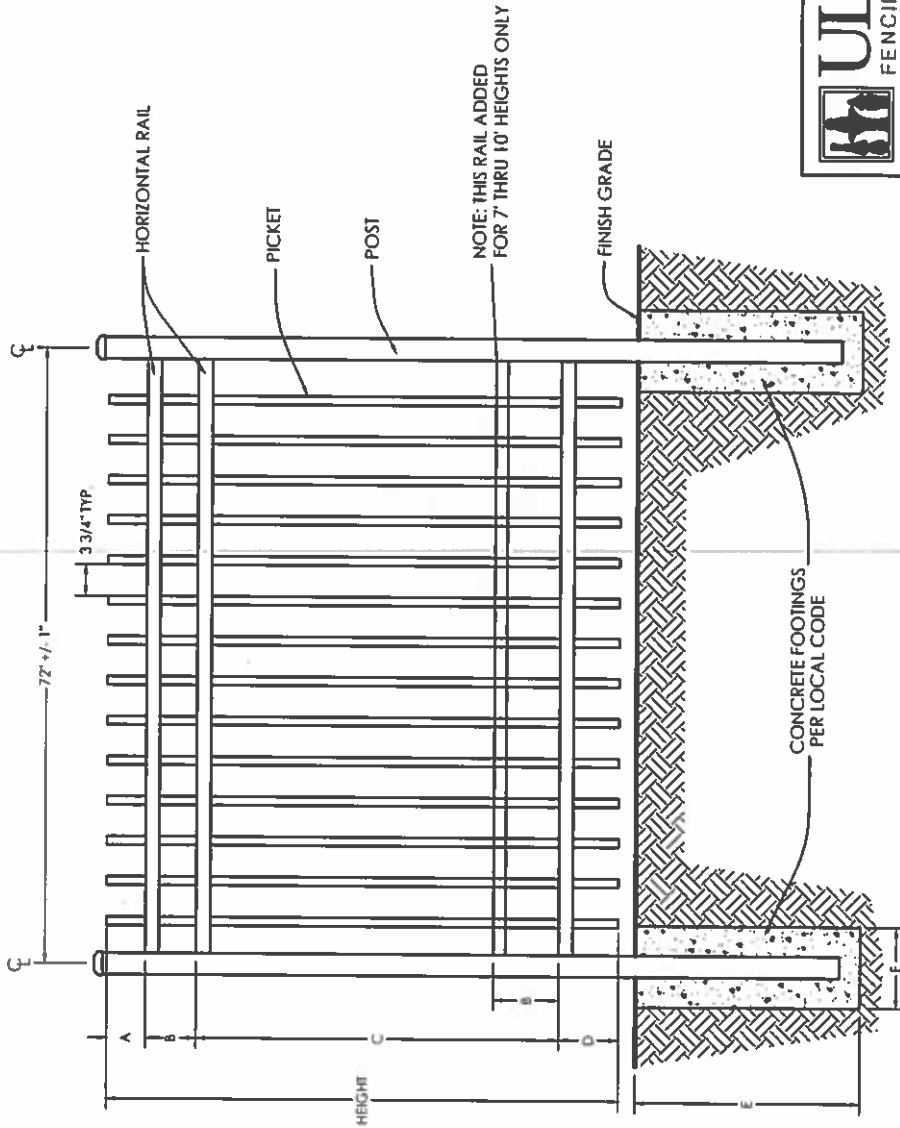

UAS-100 PLUGGED TOP INDUSTRIAL		9-1113
SPECIFICATIONS		
POSTS:	2 1/2" x 2 1/2" x 100" WALL 3" x 3" x 125" WALL 4" x 4" x 125" WALL	
HORIZONTAL RAILS:	1 5/8" W x 1 5/8" H	
SIDE WALLS	.160"	
TOP WALLS	.070"	
PICKETS:	1" x 1" x .062" WALL	
PICKET SPACING	3 3/4" BETWEEN PICKETS	

DIMENSIONS						
HEIGHT	A	B	C	D	E	F
4'	6 5/8"	7 5/8"	26 3/4"	7"	PER LOCAL CODE	PER LOCAL CODE
4 1/2'	6 5/8"	7 5/8"	32 3/4"	7"	PER LOCAL CODE	PER LOCAL CODE
5'	6 5/8"	7 5/8"	38 3/4"	7"	PER LOCAL CODE	PER LOCAL CODE
6'	6 5/8"	7 5/8"	50 3/4"	7"	PER LOCAL CODE	PER LOCAL CODE
7'	9 5/8"	10 5/8"	53 3/4"	10"	PER LOCAL CODE	PER LOCAL CODE
8'	9 5/8"	10 5/8"	65 3/4"	10"	PER LOCAL CODE	PER LOCAL CODE
9'	12 5/8"	13 5/8"	68 3/4"	13"	PER LOCAL CODE	PER LOCAL CODE
10'	12 5/8"	13 5/8"	80 3/4"	13"	PER LOCAL CODE	PER LOCAL CODE

Detail 5.6

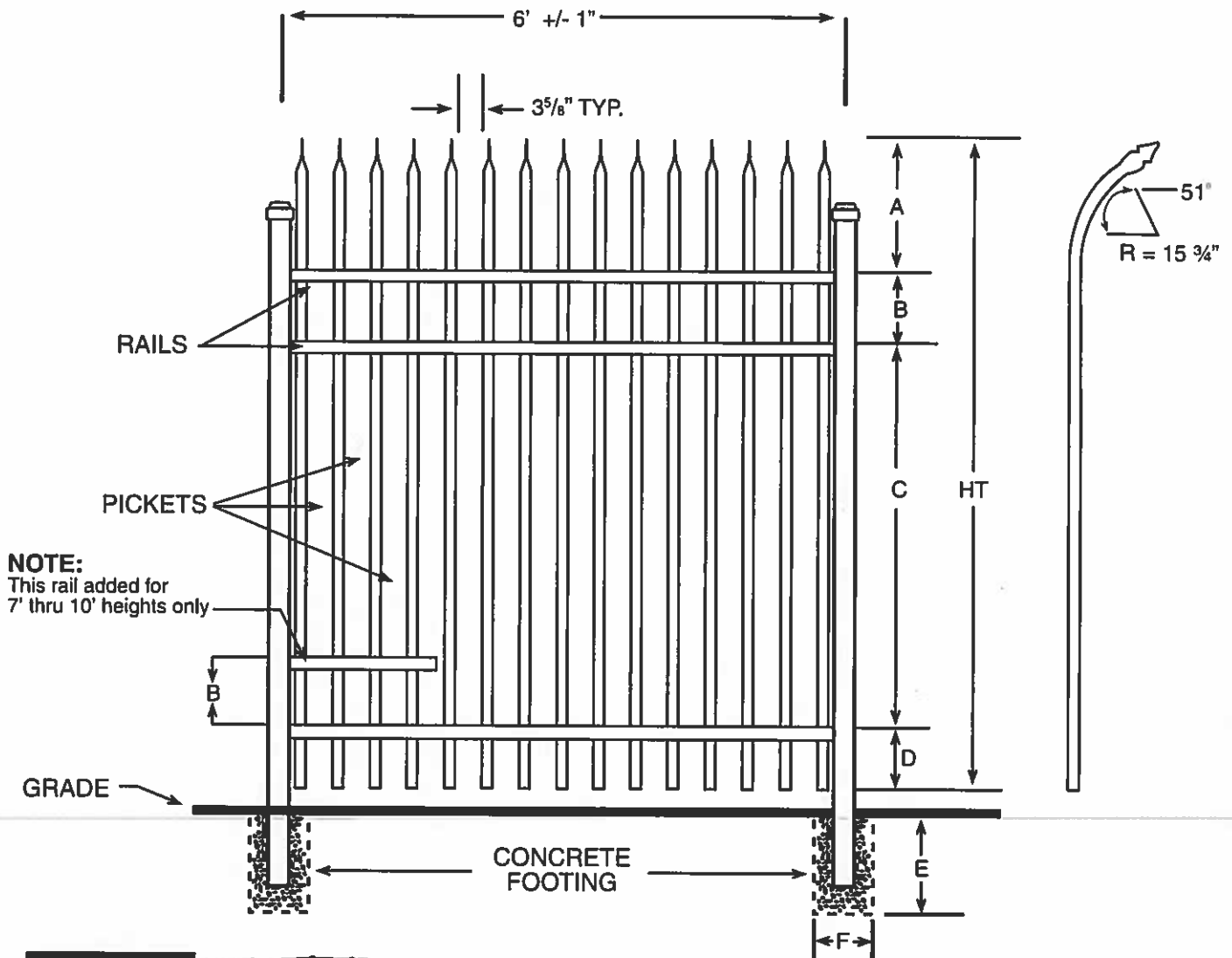

ULTRA 
ALUMINUM MFG., INC.

DEFENDER
SPEAR TOP

SPECIFICATIONS	
INDUSTRIAL	
Posts	2½" x 2½" x .100 Wall 3" x 3" x .125 Wall 4" x 4" x .125 Wall (Blanks)
Horizontal Rails Enclosed Bottom Side Walls Top Walls	1⅝" x 1⅝" Available .100" .070"
Pickets Picket Spacing	1" x 1" x .062 Wall 3⅝" or 1½"
Available Heights	7, 8, 9, & 10 Ft.

DIMENSIONS						
HT	A	B	C	D	E	F
7'	18½"	10⅝"	44¼"	10⅝"	Per Local Code	
8'	18½"	10⅝"	56¼"	10⅝"	Per Local Code	
9'	18½"	10⅝"	68¼"	10⅝"	Per Local Code	
10'	18½"	10⅝"	80¼"	10⅝"	Per Local Code	

Project:	
Owner:	
Submitted By:	Date:

Detail 5.6

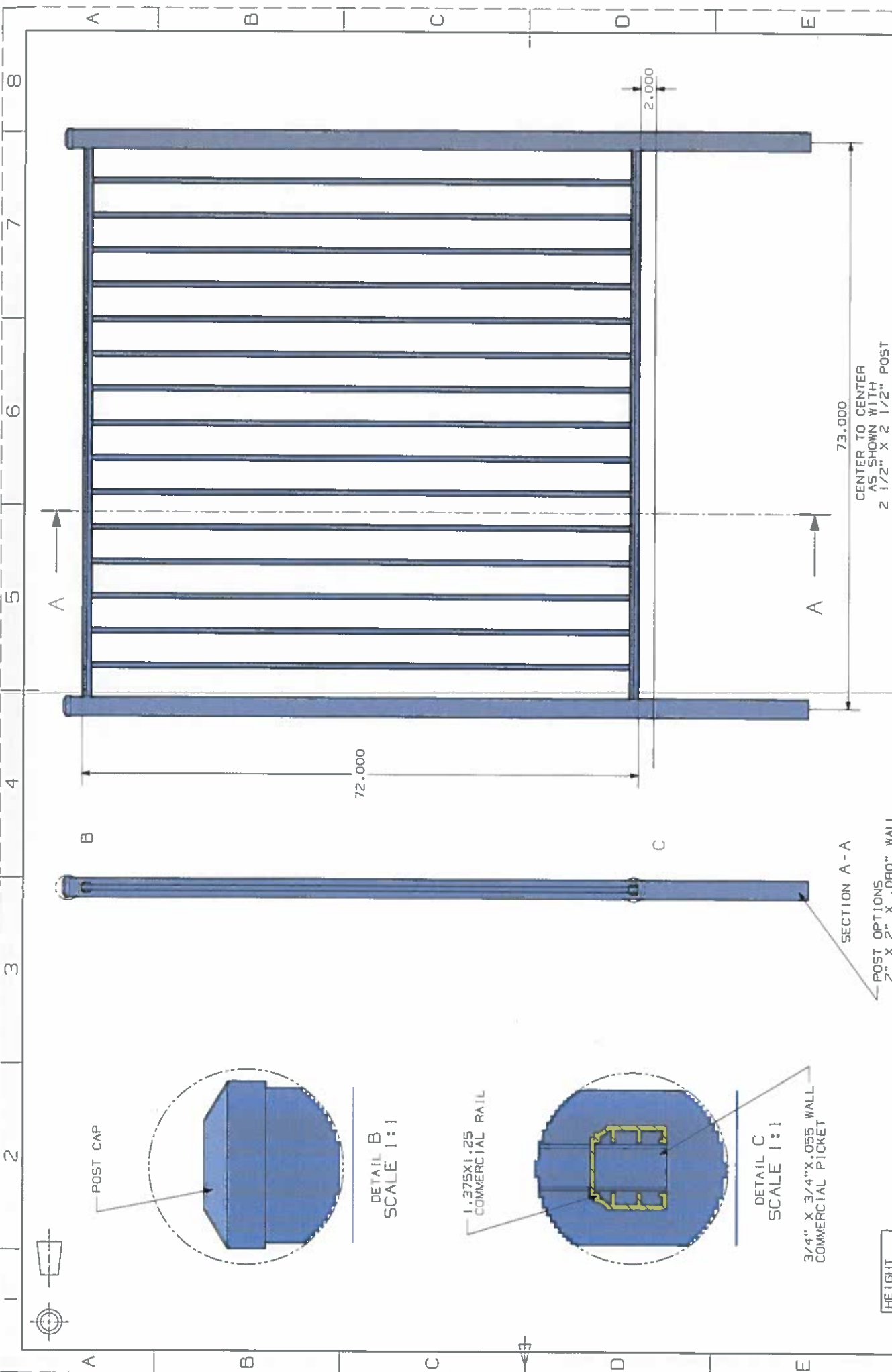

CENTER TO CENTER
AS SHOWN WITH
2 1/2" X 2 1/2" POST

SECTION A - A

- POST OPTIONS
 2" X 2" X .080" WALL
 2" X 2" X .125" WALL
 2 1/2" X 2 1/2" X .100" WALL
 3" X 3" X .125" WALL

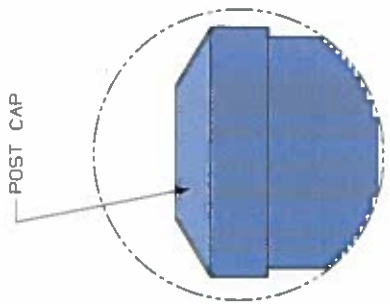

DETAIL B
SCALE 1:1

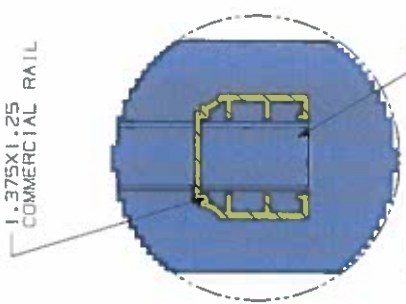

DETAIL C
SCALE 1:1

3/4" X 3/4" X .055 WALL
COMMERCIAL PICKET

HEIGHT
3'
3 1/2'
4'
4 1/2'
5'
6'

	TITLE	UAF-200 FLAT TOP FLUSH BOTTOM 2" RAIL COMMERCIAL
	DRAWN BY	
	CHECKED BY	
APPROVED BY		
ULTRA ALUMINUM MANUFACTURING, INC. 2124 GRAND COMMERCE DR., HOWELL, MI 48855 PHONE (800) 656-4420 FAX (800) 646-7420	SIZE/DRG. NO.	1857
UAF-200 FLAT TOP FLUSH BOTTOM 2" RAIL COMMERCIAL	C.	UAF 200 FLAT TOP FLUSH BOTTOM 2" RAIL COMMERCIAL
SCALE 1:1		SHEET 1 OF 1

Detail 5.6

ALL DIMENSIONS IN INCHES

3D CAD MASTER PART NAME:

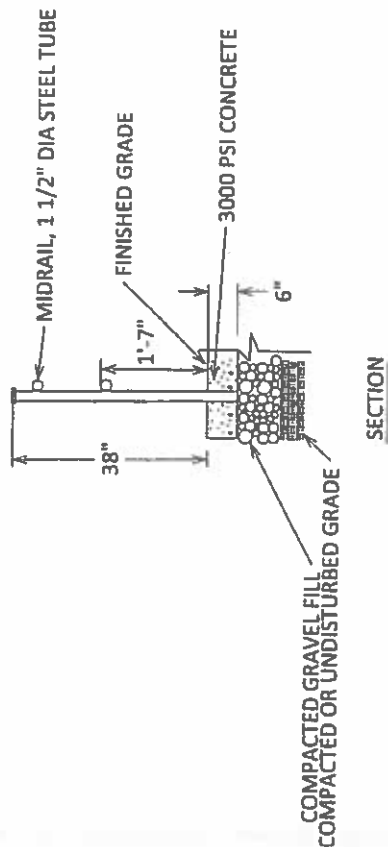
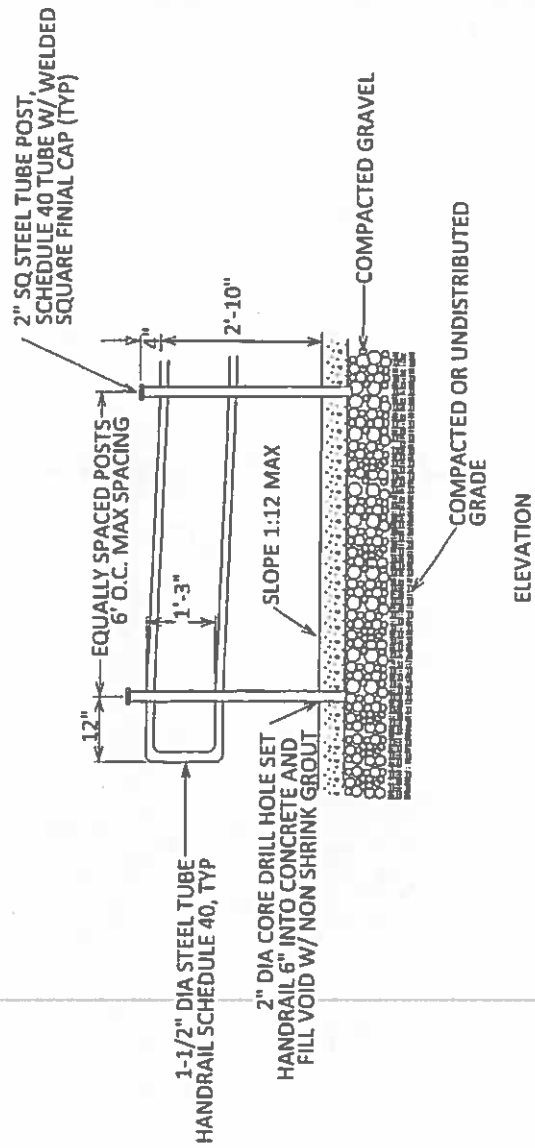

RAMP HANDRAIL
NTS

DETAIL 5.7

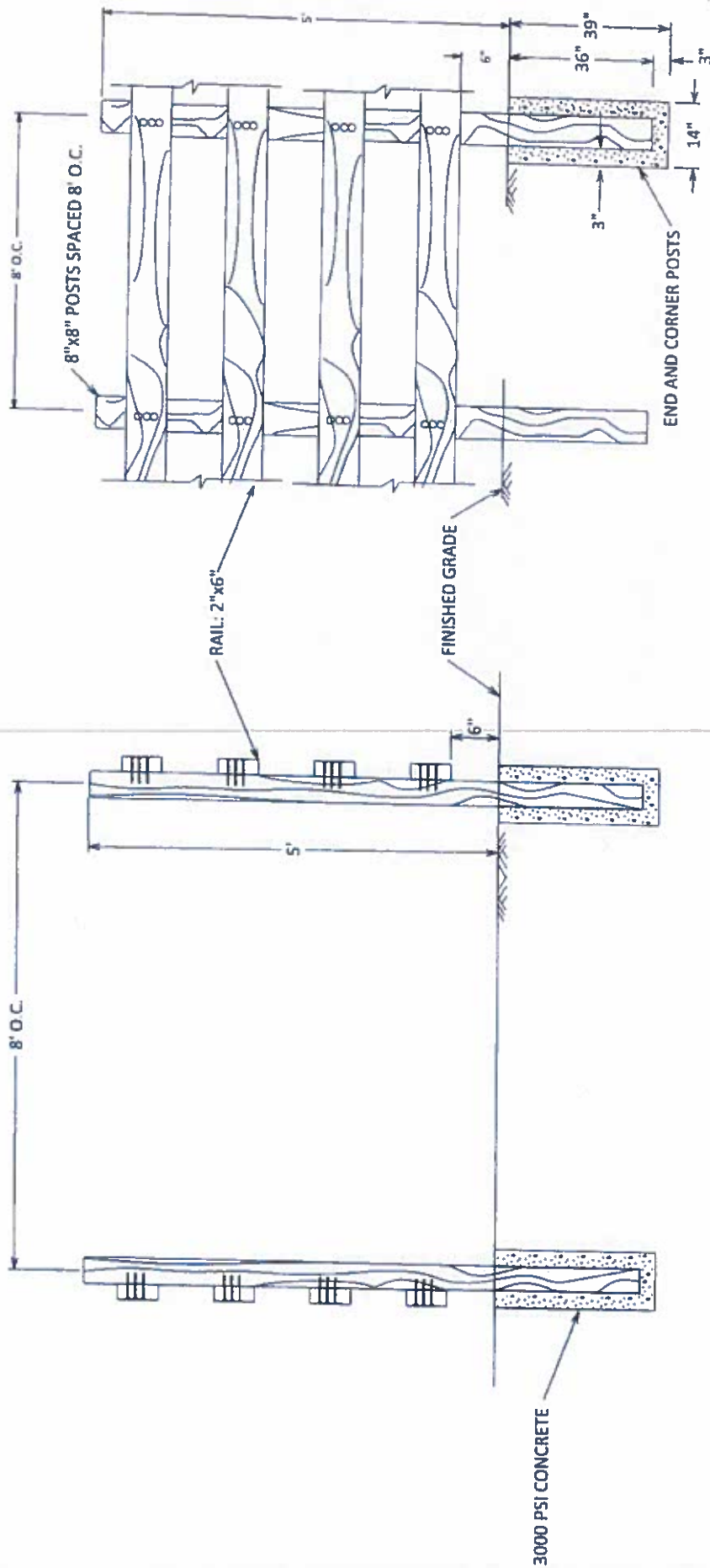

ELEVATION

SECTION

HORSE PARK FENCE
NTS

DETAIL 5.8

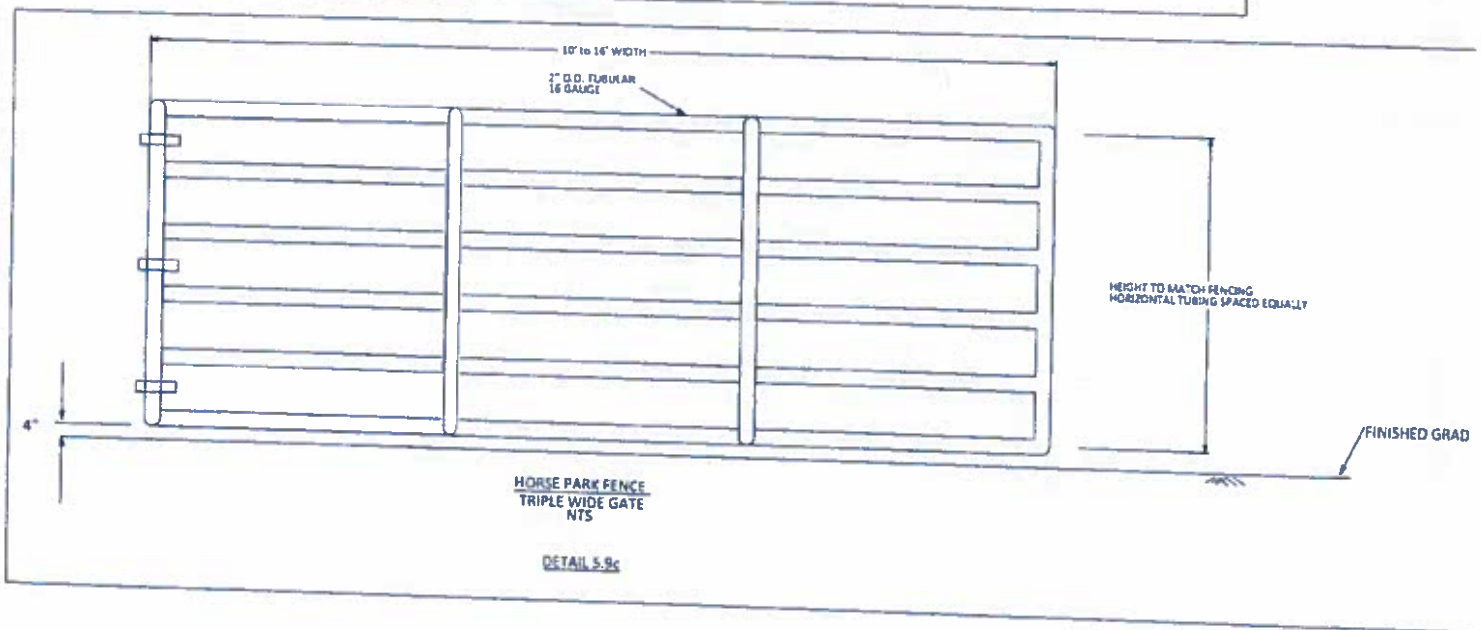
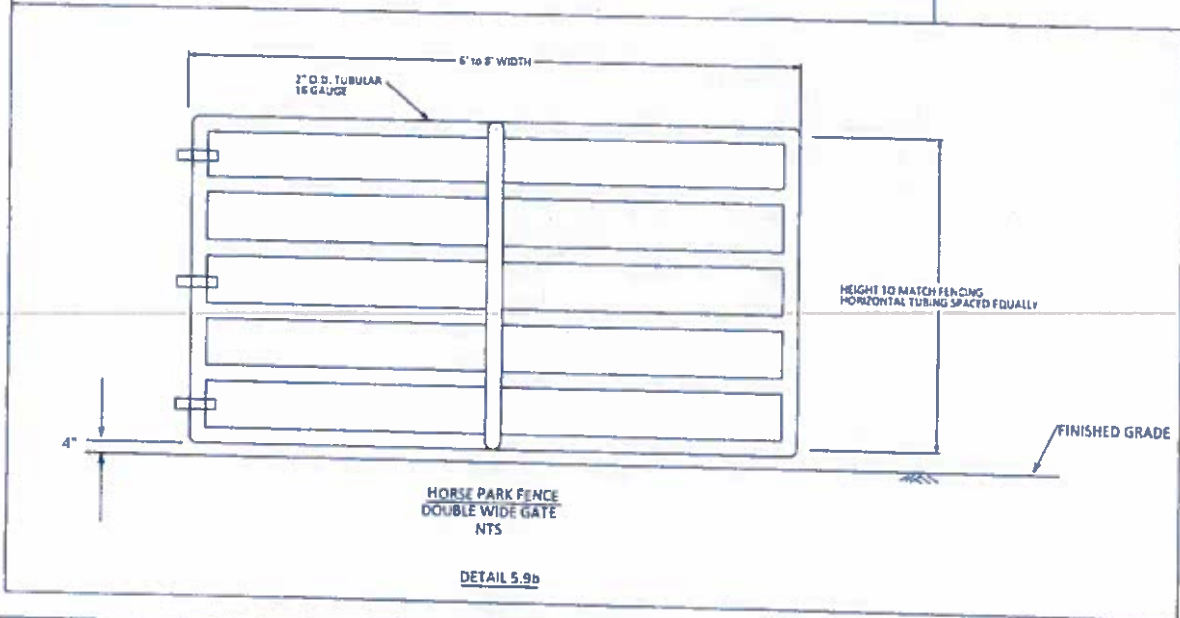
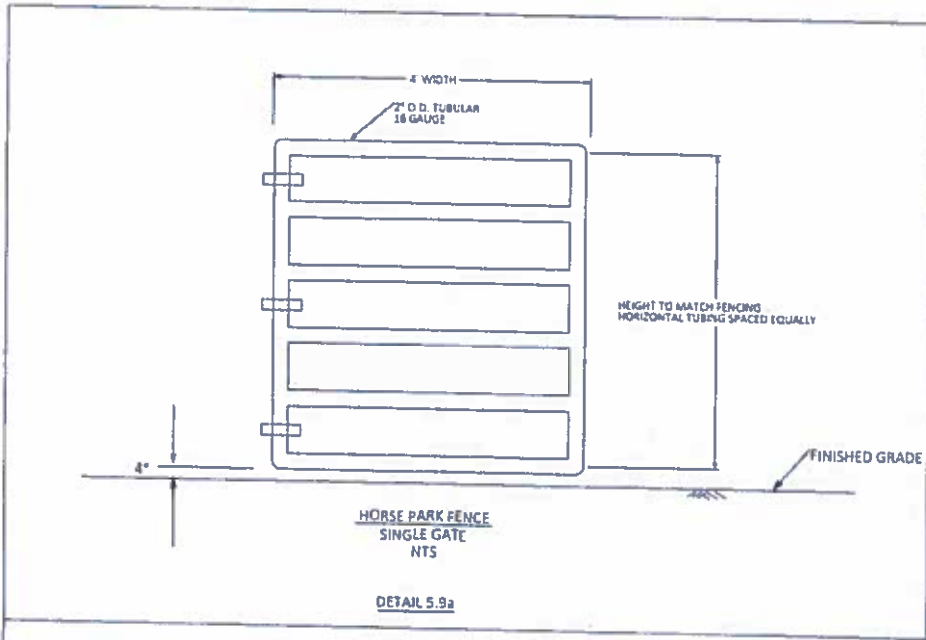

Boston Garden Post and Chain
 www.snugcottagehardware.com
 Model: 5200-48A or 5200-72A

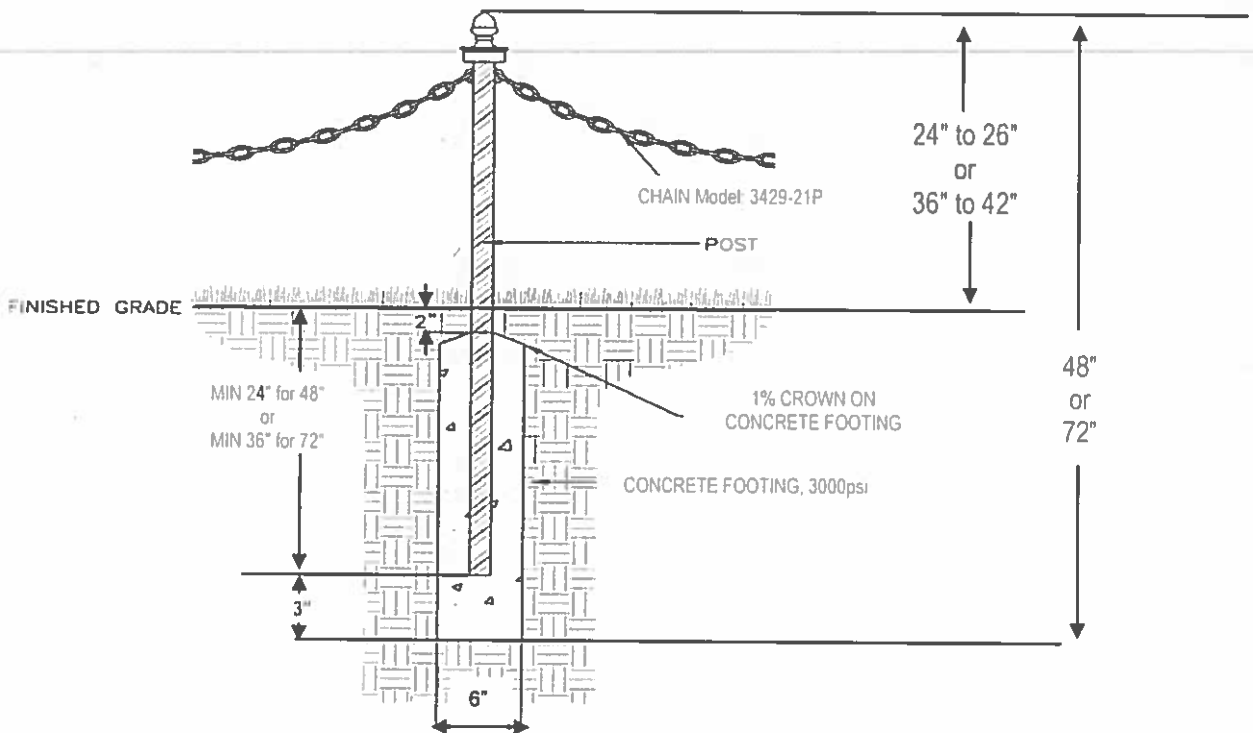
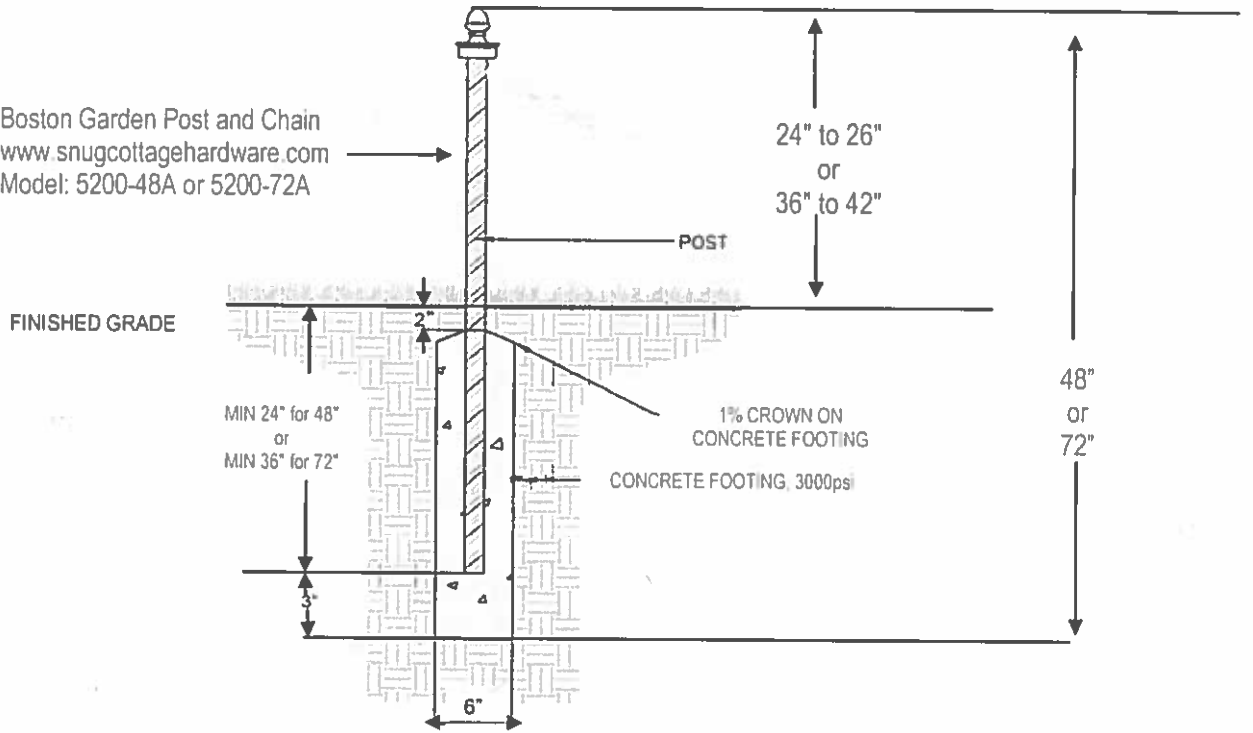

PEDESTRIAN BOLLARD AND BOLLARD W/CHAIN

NTS

Detail 5.10

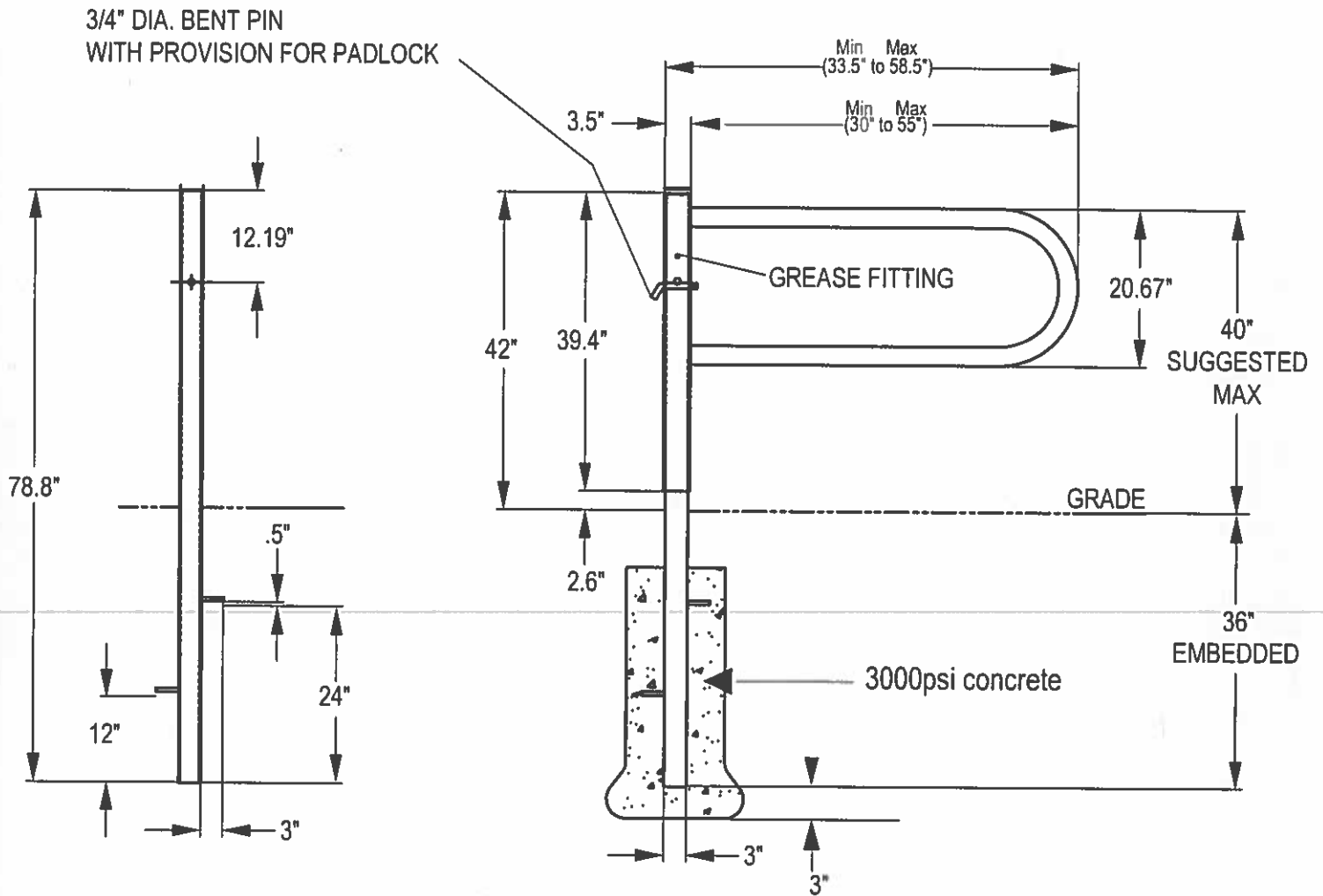

SWING GATE LOCKABLE BOLLARD

NTS

Detail.5.11

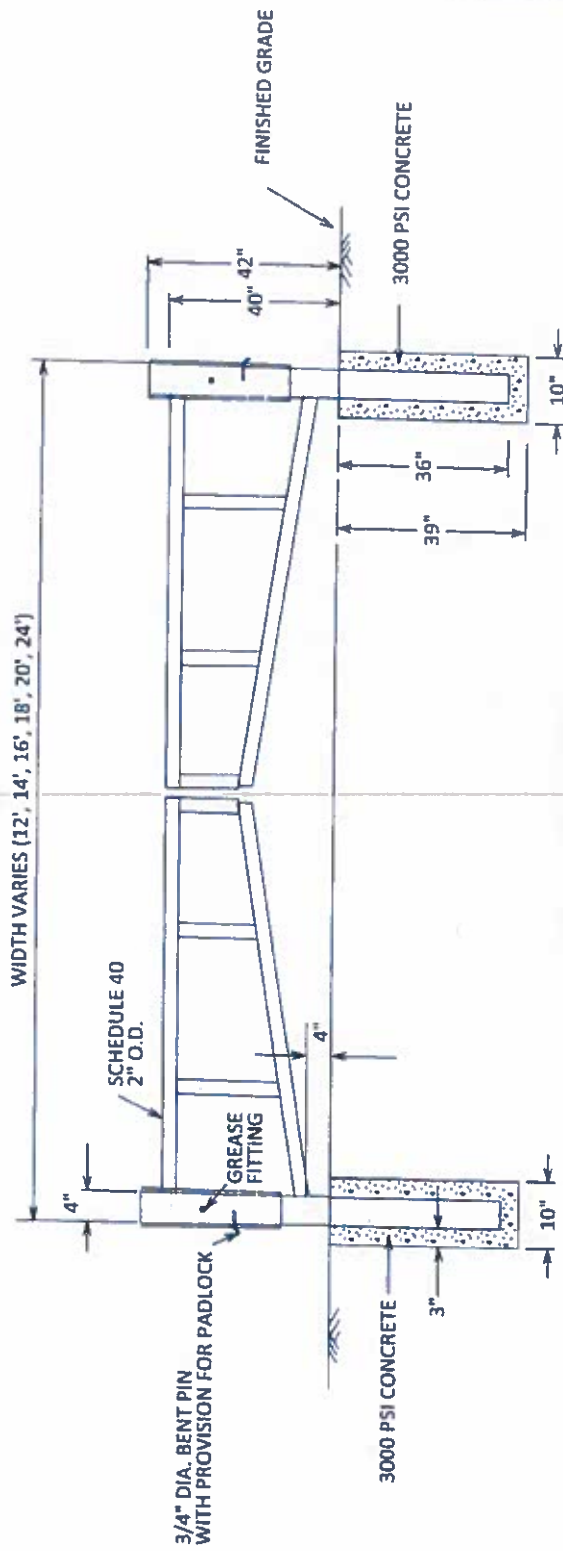

SECTION - DOUBLE SWING GATE

NTS
DETAIL 5.12a

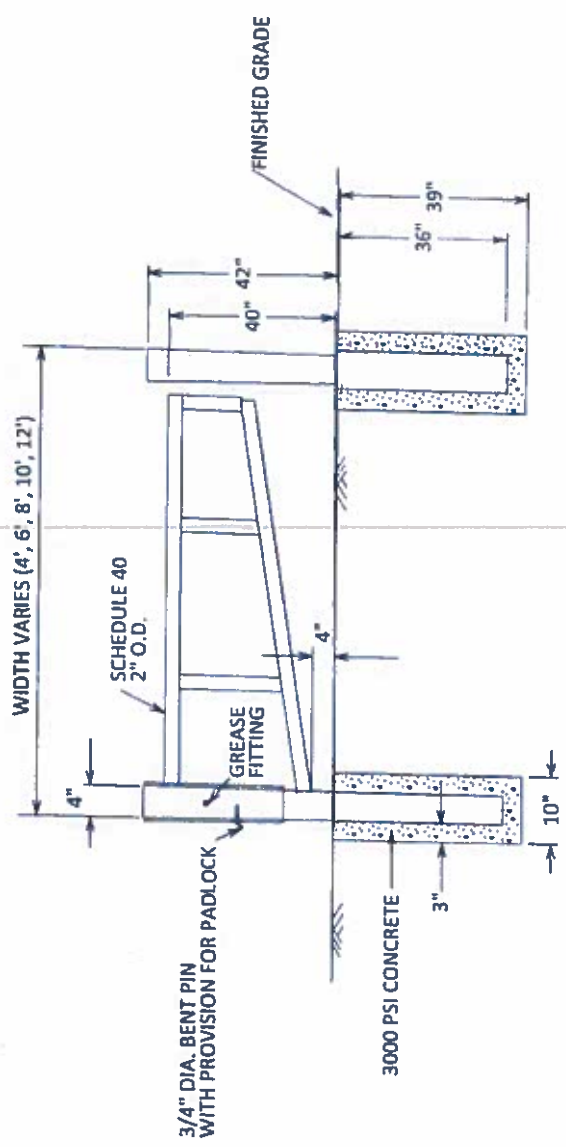

SECTION - SINGLE SWING GATE

NTS
DETAIL 5.12b

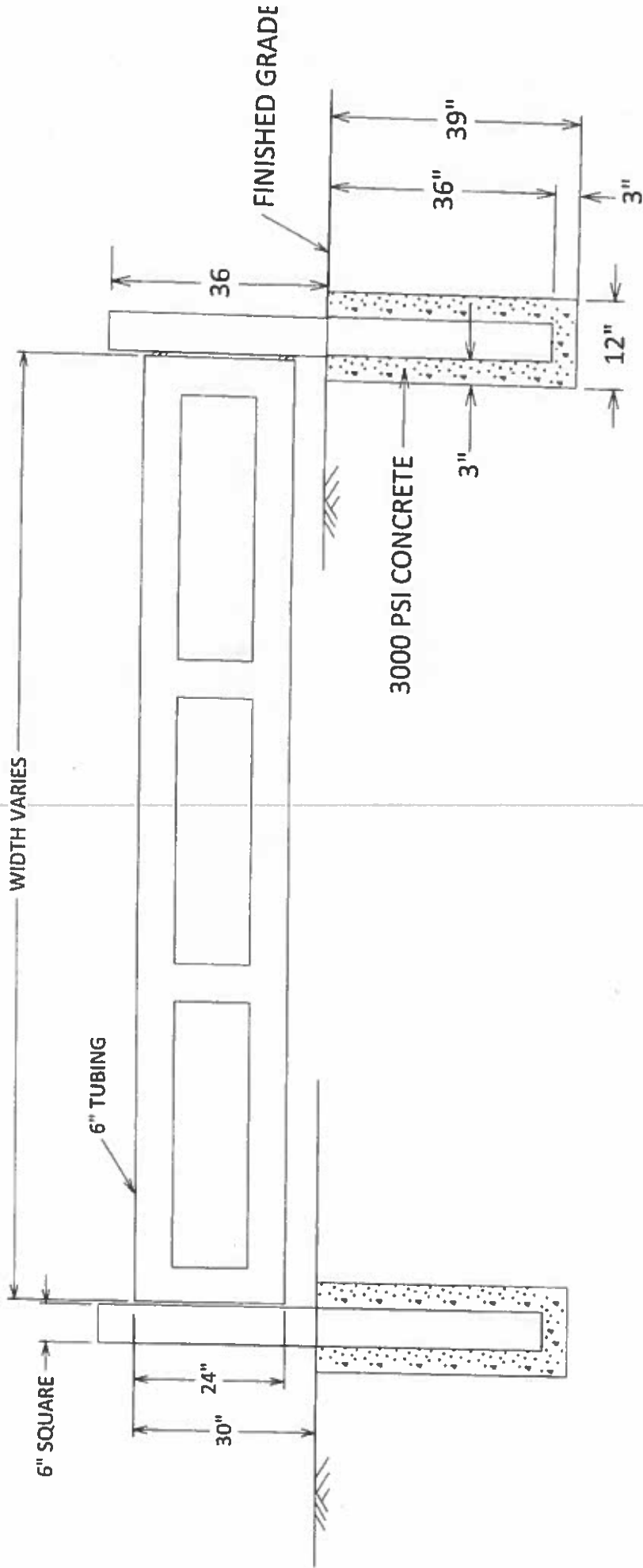

HEAVY DUTY STEEL SINGLE GATE
 NTS

DETAIL 5.13

TF-031-1 DRAWING NUMBER:		ARCHITECT/ENGINEER:	
SHEET NUMBER: 1 OF 2		CONTRACTOR:	
PROJECT: Dekalb Parks & Recreation		SUBJECT: 2150-W4 Pedestrian Swing Gate (4'-0" x 7'-0" Opening)	
DRAWN BY: MNS		CHECKED BY: BGG	
DATE: 5/6/15		DATE: 5/6/15	
SCALE: As Noted		REVISION LEVEL: R0	
PROPRIETARY & CONFIDENTIAL The information contained in this drawing is the sole property of TYPETAL CORP. Any reproduction in part or as a whole without the written permission of TYPETAL CORP. is prohibited.			
TYPETAL CORP. 678 WILBUR AVENUE GREENWICH, N.Y. 12834 (900) 328-4283 - FX (518) 692-9404 www.tymetal.com			

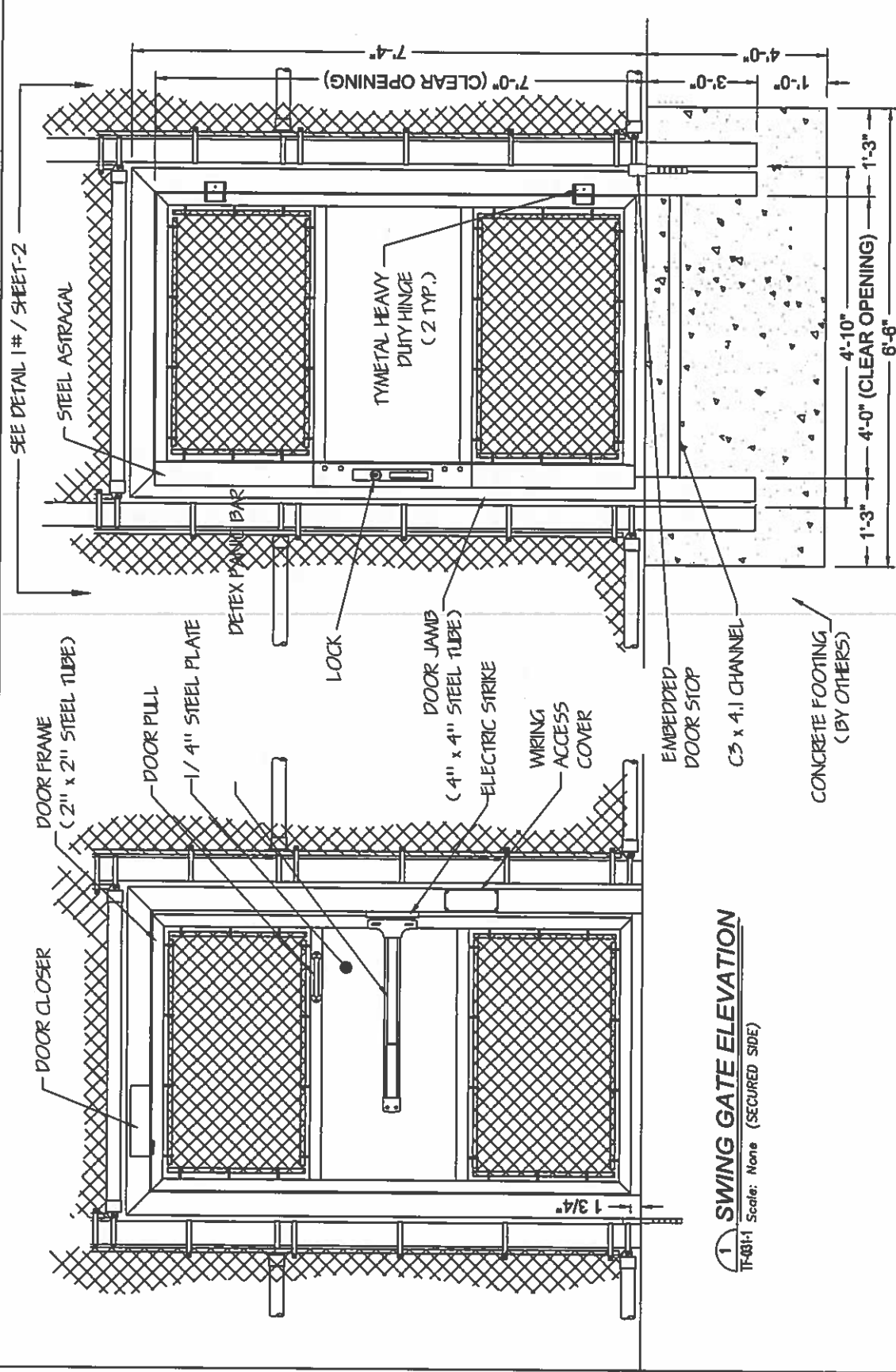

1 SWING GATE ELEVATION
 TF-031-1 Scale: None (SECURED SIDE)

2 SWING GATE ELEVATION
 Scale: None (UN-SECURED SIDE)

- NOTES:**
1. THE OPENING IN THE FENCE LINE SHALL BE BUILT TO ACCOMMODATE THE DOOR JAMB PER THE OWNERS SPECIFICATIONS.
 2. GATE FRAME WILL BE FILLED WITH 2x9 GA. ALUMINIZED CHAIN LINK.
 3. DETEX 40 PANIC BAR W/TRIM PACKAGE FOR KEYING FROM OPPOSITE SIDE AND 1/8 TURN DOGGING FEATURE.

Detail E 14a

TF-031-2
 SHEET NUMBER:
 2 OF 2
 DRAWING NUMBER:
 2150-W4 Pedestrian Swing Gate Details

PROJECT:
 Dekalb Parks & Recreation
 SUBJECT:
 2150-W4 Pedestrian Swing Gate Details
 CONTRACTOR:
 ARCHITECT/ENGINEER:

DATE: 5/8/15
 DRAWN BY: MNS
 CHECKED BY: BGG
 DATE: 5/8/15
 SCALE:
 As Noted
 REVISION LEVEL:
 R0

PROPRIETARY & CONFIDENTIAL
 The information contained in this drawing is the sole property of TYMETAL CORP. Any reproduction in part or as a whole without the written permission of TYMETAL CORP. is prohibited.
 TYMETAL CORP.
 www.tymetal.com
 678 MILBUR AVENUE
 GREENWICH, N.Y. 12834
 PH: (800) 328-1263 - FX: (518) 692-9404

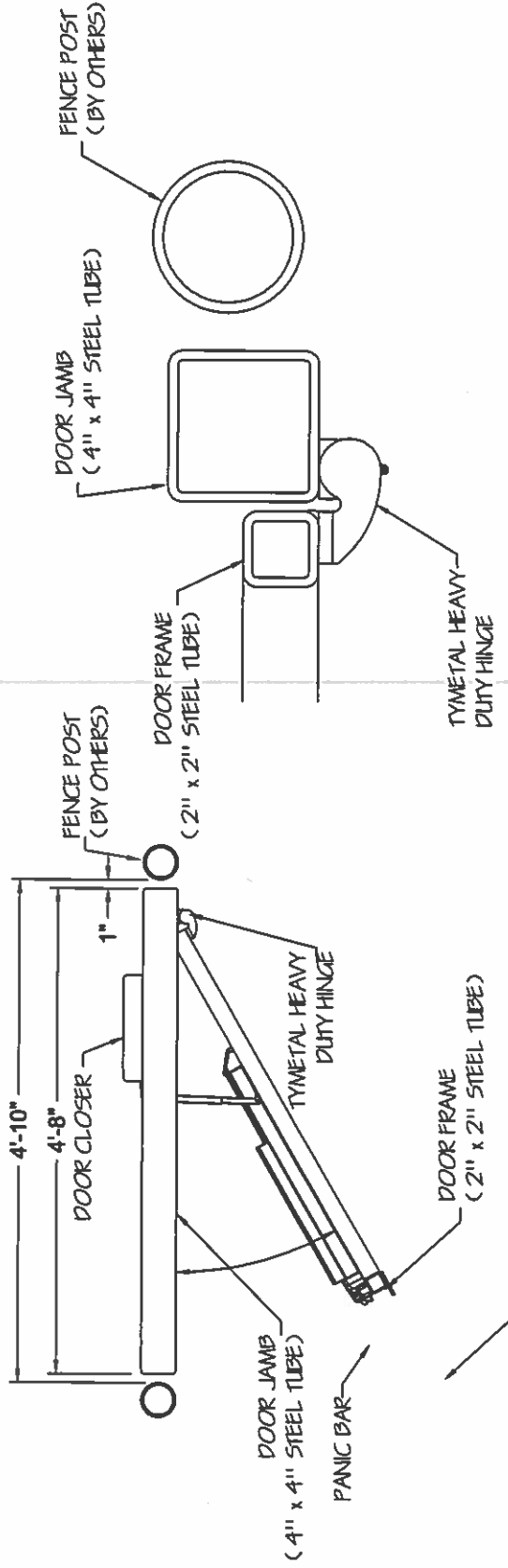

2 HINGE DETAIL
 Scale: None

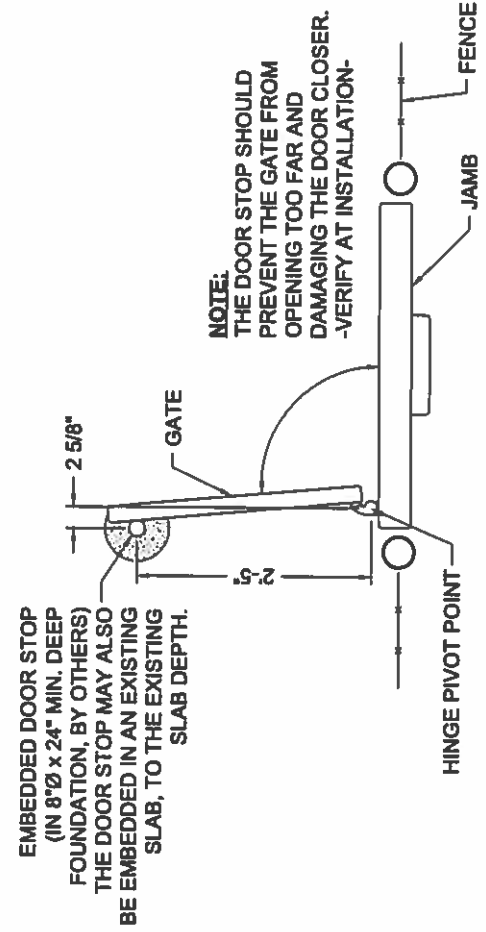
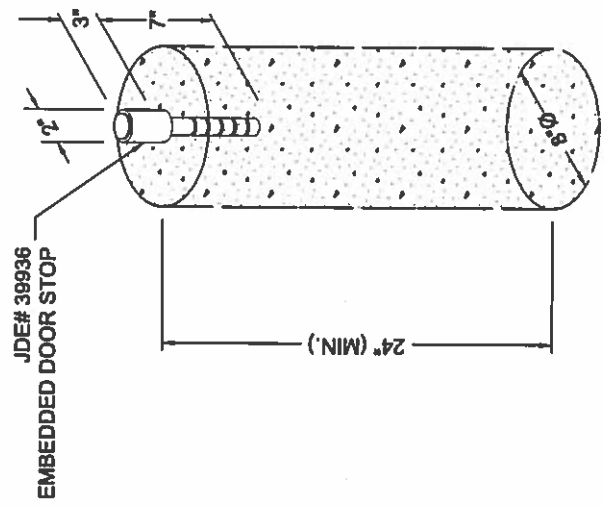

NOTE:
 THE DOOR STOP SHOULD PREVENT THE GATE FROM OPENING TOO FAR AND DAMAGING THE DOOR CLOSER.
 -VERIFY AT INSTALLATION-

4 EMBEDDED DOOR STOP
 Scale: None

3 2150 PLAN VIEW
 Scale: None

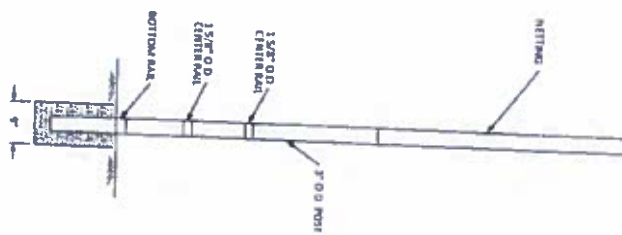
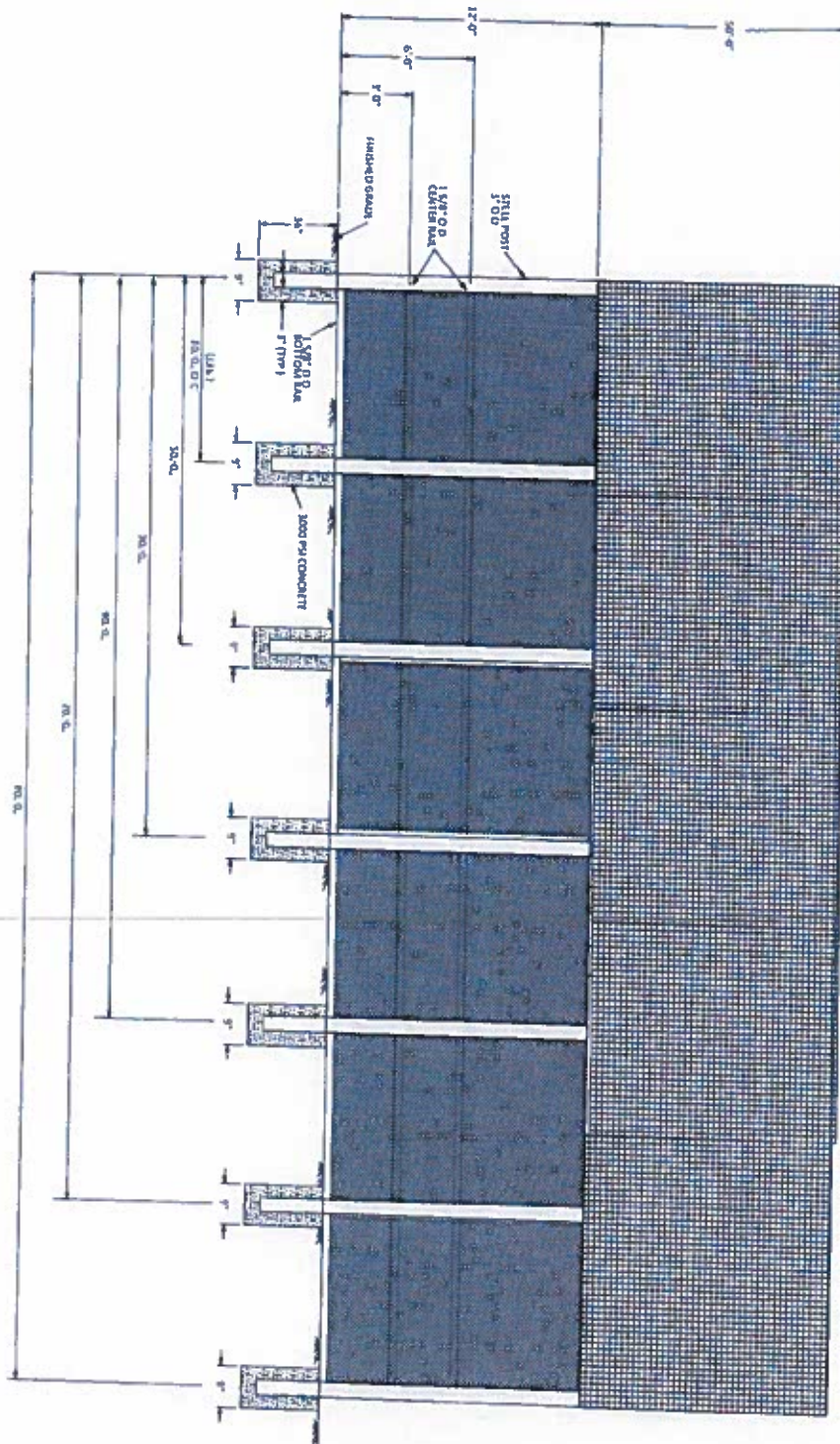

REINFORCEMENT
 PLAN
 DETAIL 5.17

