



**DeKalb County
Department of Purchasing and Contracting**

Maloof Administration Building, 1300 Commerce Drive, 2nd Floor, Decatur, GA 30030

January 21, 2020

INVITATION TO BID (ITB) NO. 20-101212

FOR

**SCOTT CANDLER WATER TREATMENT PLANT - OZONE GENERATORS
DESIGN AND INSTALLATION**

DEKALB COUNTY, GEORGIA

Procurement Agent:	Cornell Brown
Phone:	(404) 687-3949
Email:	cbrown1@dekalbcountyga.gov
Mandatory DeKalb First LSBE Meeting: (Bidders must attend 1 meeting on either of the dates listed.)	<u>January 22, 2020 & January 29, 2020</u> 4572 Memorial Drive, Decatur, Georgia 30032 Conference Room - B (Meetings are held at 10:00 a.m. and 2:00 p.m.) Video Conference: Utilize the link supplied on our webpage labeled "DeKalb First LSBE Video Meeting"
Pre-Bid Conference and Site Visit: (MANDATORY)	<u>January 28, 2020, 10:00 A.M. EST.</u> , Scott Candler Water Treatment Plant, 4830 Winters Chapel Road, Doraville, GA 30360
Deadline for Submission of Questions:	<u>5:00 P.M. ET, January 31, 2020</u>
Bid Opening:	<u>3:00 P.M. ET, February 27, 2020</u>
Price Schedule Opening:	3 – 5 Business days after Bid Opening

**THE RESPONSIBILITY FOR SUBMITTING A RESPONSE TO THIS BID TO
THE DEPARTMENT OF PURCHASING AND CONTRACTING OF DEKALB
COUNTY GOVERNMENT ON OR BEFORE THE STATED DATE AND TIME
WILL BE SOLELY AND STRICTLY THE RESPONSIBILITY OF THE BIDDER.**

<u>TABLE OF CONTECTS</u>	<u>Page Number</u>
Acknowledgment of Bidder	3
Instructions to Bidders	4
Scope of Work	19
Bidder's Unit Price Form	26
Bid Bond Acknowledgment and Bid Bond Form	29
DeKalb First LSBE Information with Exhibits 1-2 & Mentor-Protégé Initiative Form	33
First Source Jobs Ordinance Information with Exhibits 1 - 4	43
Certificate of Corporate Bidder	47
Certificate of Authority – Joint Venture Bidder	48
Bidder's Affidavit of Compliance with O.C.G.A. §13-10-91	49
Subcontractor's Affidavit of Compliance With O.C.G.A. §13-10-91	50
Contractor Reference and Release Form	51
Subcontractor Reference and Release Form	52
Contractor Affidavit and Oath of Successful Bidder	53
Required Documents Checklist	54
Sample-Standard Form Contract for Construction	56
Technical Specifications	Exhibit 1
Specifications and Functional Design of the Existing Generator & Facilities	Exhibit 2
Contractual Standards and Regulations	Exhibit 3
Technical Criteria-Ozone Generators	Exhibit 4

ACKNOWLEDGEMENT OF BIDDER

I _____ have had the opportunity to review and have reviewed this Bid Document Package dated _____, 20__ in its entirety and I agree that it is accurate and complete. I _____ am duly and properly in office and I am fully authorized and empowered to execute this Acknowledgement for and on behalf of the Contractor.

By: _____ (SEAL)
Signature

Name (Typed or Printed)

Title

Name of Business

Federal Tax I.D. Number

ATTEST:

Signature

Name (Typed or Printed)

Title

INSTRUCTIONS TO BIDDERS

GENERAL

Sealed Bids will be received by DeKalb County, Georgia, in the Department of Purchasing and Contracting, The Maloof Center, 2nd Floor, 1300 Commerce Drive, Decatur, Georgia 30030, until **3:00 p.m.** on the **27th** day of **February, 2020**, for ITB 20-101212 according to the Drawings and Specifications entitled **Scott Candler Water Treatment Plant - Ozone Generators Design and Installation** on file in the Department of Purchasing and Contracting, The Maloof Center, 2nd Floor, 1300 Commerce Drive, Decatur, Georgia 30030. Bidder's Unit Price Forms shall be opened and read aloud 3 to 5 business days after Bid Opening Date. Sealed Bids shall be submitted on the form furnished by the County and shall be submitted in **triplicate**, designated as original or copy.

SUBMIT ONE ORIGINAL BID PACKAGE (INCLUSIVE OF THE ENTIRE INVITATION TO BID DOCUMENT AND REQUIRED DOCUMENTS WITH THE EXCEPTION OF THE BID PRICE FORM) STAMPED "ORIGINAL" AND TWO SEALED IDENTICAL COPIES STAMPED "COPY" OF THE BID PACKAGE TO THE ADDRESS LISTED ABOVE.

Bids will be considered only from experienced and well-equipped contractors. Prior to beginning construction, the successful Bidder will file with the County a Performance Bond and a Payment Bond, each equal to 100% of the Contract Price, with the terms and surety to be approved by the County; and furnish satisfactory proof of carriage of the insurance required.

SUBMITTING BIDS

Bids are to be submitted on the proper unaltered forms, and shall be addressed to the DeKalb County Department of Purchasing and Contracting, The Maloof Center, 2nd Floor, 1300 Commerce Drive, Decatur, Georgia 30030, sealed, dated and enclosed in an envelope or package appropriately marked on the outside with the name of the Bidder, the date and hour of opening, and the Invitation to Bid Number and Project Name.

FAILURE TO SUBMIT THE BID PRICE FORM IN A SEPARATE SEALED ENVELOPE SHALL DEEM THE BID NON-RESPONSIVE. INCLUDING THE PRICE SCHEDULE IN ANY AREA OUTSIDE OF ITS SEPARATE, SEALED ENVELOPE WILL RESULT IN BIDDER'S BID BEING DEEMED NON-RESPONSIVE.

It is the responsibility of each Bidder to ensure that its submission is received by 3:00 p.m. on the bid due date. The time/date stamp clock located in the Department of Purchasing & Contracting shall serve as the official authority to determine lateness of any bid. The bid opening time shall be strictly observed. Be aware that visitors to our offices will go through a security screening process upon entering the building. Bidders should plan enough time to ensure that they will be able to deliver their submission prior to our deadline. Late submissions, for whatever reason, will not be evaluated. Bidders should plan their deliveries accordingly. Telephone or fax bids will not be accepted.

PRICE SCHEDULE OPENING

Price Schedule openings shall be conducted in the Department of Purchasing and Contracting three (3) to five (5) days after the bid opening. Only the Price Schedules of responsive bidders shall be opened. The County reserves the right to decide which bid(s) will be deemed responsive and said determination shall be made in accordance with the requirements stated in this solicitation. Any reference to the Bidder's Unit Price, Bidder's Unit Price Form, or Price Schedule shall be deemed to be in reference to the Bidder's Unit Price Form.

BUSINESS AND PROFESSIONAL LICENSE

Bidders shall submit a copy of its current, valid business license with its Bid or upon award. If the Bidder is a Georgia corporation, Bidder shall submit a valid county or city business license. If Bidder is a joint venture, Bidder shall submit valid business licenses for each member of the joint venture. If the Bidder is not a Georgia corporation, Bidder shall submit a certificate of authority to transact business in the state of Georgia and a copy of its current, valid business license issued by its home jurisdiction. If Bidder holds a professional license, then Bidder shall submit a copy of the valid professional license. Failure to provide the business license, certificate of authority, or professional license required by this section, may result in the proposed Bid being deemed non-responsive.

UTILITY SYSTEMS CONTRACTOR'S LICENSE

As required by O.C.G.A. § 43-14-8, *et seq.*, a Bidder responding to this Invitation to Bid must provide a copy of its or its subcontractor's Georgia Utility Systems Contractor's License, Utility Manager's Certificate with its Bid. All licenses and certificates must be issued in the name of the person or entity that will perform the utility work. If a subcontractor's Georgia Utility Systems Contractor's License is submitted with the Bid, the subcontractor must be listed as such on the appropriate Bond Acknowledgement Form. All licenses and certificates must be current, valid, and issued in compliance with applicable law. Failure to provide these licenses and necessary certificates in this format will result in the proposed Bid being deemed non-responsive.

QUESTIONS, ADDENDA AND INTERPRETATION

All questions concerning the Project, requests for interpretation of the solicitation and contract exceptions may be asked and answered at the pre-bid conference; however, oral answers are not authoritative. Questions and exceptions must be submitted to the Department of Purchasing and Contracting in writing via email to cbrown1@dekalbcountyga.gov. Questions, requests for information or clarification concerning the specifications in this ITB and contract exceptions must be submitted to the above listed contact person via email no later than the date and time listed in the bid timetable. Questions, requests for interpretation and exceptions received after the above stated time or sent to anyone other than the listed contact person will not receive a response or be the subject of addenda. For questions, requests for interpretation, and contract exceptions submitted after the pre-bid conference, each response shall be given in written addendum, separately numbered and dated, and published on the County website in sufficient time for interested parties to review. **No responses to requests, answers to specification questions, or additional information shall be supplied after “January 31, 2020”**

ACKNOWLEDGMENT OF ADDENDA

Addenda may be issued in response to changes in the Invitation to Bid. Mandatory addenda must be acknowledged by signing and returning the Addendum Acknowledgement with the Bid. Acknowledgments must be received by the County before the Bid opening time and date. Failure to properly acknowledge any mandatory addendum will result in the proposed Bid being deemed

non-responsive. Bidder may call Cornell Brown at (404) 687-3949 or send an email to cbrown1@dekalbcountyga.gov to verify the number of addenda prior to submission. All addenda issued for this Project may be found on DeKalb County's website, <http://www.dekalbcountyga.gov/formalbids>.

AUTHORITY TO SIGN

If a Bid is submitted by an individual, his/her name and mailing address must be shown. If submitted by a corporation, partnership, or joint venture, the name and physical mailing address of each member of the corporation, partnership, or joint venture must be shown. If submitted by a corporation, the Certificate of Corporate Bidder in the form attached to the Bid Document Package must be executed and submitted with the Bid. If submitted by a joint venture, the Certificate of Authority – Joint Venture in the form attached to the Bid Document Package must be executed and submitted with the Bid. A post office box is not acceptable as a physical mailing address. The legal and proper name of the proprietorship, corporation, or partnership submitting the Bid shall be printed or typed in the space provided on the Certificate of Corporate Bidder.

BID GUARANTEE TO ACCOMPANY BID

Each Bid must be accompanied by a Bid Guarantee in an amount of not less than ten percent (10%) of the amount of the Bid. The Bid Guarantee may be in the form of an official bank check payable to DeKalb County, or a Bid Bond in the form provided in the Bid Document Package. The Bid Bond shall be issued by a surety company licensed to write bonds in the State of Georgia, listed in the most current U.S. Treasury Circular No. 570, and have a current A.M. Best rating of "A" (Excellent) with a Financial Size Category of XII or better.

THE BID GUARANTEE MUST NOT BE INCLUDED IN THE SEPARATE SEALED ENVELOPE WITH THE BIDDER'S UNIT PRICE FORM

VALID INSURANCE, BONDS, LICENSES, PERMITS, AND CERTIFICATES

Bidder shall ensure that any bond, bid bond, payment bond, performance bond, insurance, license, permit or certificate submitted in response to this Invitation to Bid or as part of the Contract for

this Project shall be current and valid when submitted, and shall remain valid, current and maintained in good standing for the Contract Term.

CONTRACTOR’S INSURANCE COVERAGE

A. Upon award the Contractor shall, without expense to the County, provide certificates of insurance, and copies of signed insurance policies including declarations pages from companies that are authorized to engage in the insurance business in the state of Georgia and are otherwise acceptable to the County Finance Director or his/her designee. Such insurance shall be placed with admitted insurers that maintain an A.M. Best's rating of not less than A (Excellent) with a Financial Size Category of VII or better with coverage forms acceptable to Contractor. The insurance described below shall be maintained uninterrupted for the duration of the project, including any warranty periods, and shall protect Contractor, and others as required by contract, for liabilities in connection with work performed by or on behalf of Contractor, its agents, representatives, employees or Contractors.

(1) *Workers Compensation Insurance.* Statutory workers compensation insurance is to be provided in compliance with the requirements of Georgia law with limits not less than the following:

- Employer’s liability insurance by accident, each accident \$1,000,000
- Employer’s liability insurance by disease, policy limit \$1,000,000
- Employer’s liability insurance by disease, each employee \$1,000,000

(2) *Commercial General Liability Insurance.* Commercial general liability insurance is to be provided with limits not less than the following:

- \$1,000,000 per occurrence for bodily injury and property damage liability
- \$1,000,000 personal and advertising injury liability
- \$2,000,000 general aggregate
- \$2,000,000 products-completed operations aggregate
- \$ 100,000 damage to rented premises (each occurrence)
- \$ 5,000 medical expense (any one person)

(3) *Umbrella or Excess Insurance.* Umbrella or excess insurance is to be provided with General Liability, Auto Liability and Employers Liability scheduled as underlying policies with limits not less than the following:

- \$5,000,000 per occurrence
- \$5,000,000 aggregate

- (4) *Comprehensive Automobile Liability Insurance.* Comprehensive automobile liability insurance with form coverage is to be provided for all owned, non-owned and hired vehicles with combined single limit of \$1,000,000. Automobile liability insurance shall be written on ISO Business Auto Coverage Form CA 0001 (1990 edition or later), or a substitute form providing equivalent coverage, and shall cover liability for bodily injury and property damage arising from the use or operation of any automobile, including those owned, hired or otherwise operated or used by or on behalf of Contractor. The policy must include Broadened Pollution Liability Endorsement CA9948 12 93.
- (5) *Builder’s Risk Insurance Coverage.* DeKalb County shall procure and maintain Builders Risk Insurance on the entire work which provides “All-risk” form that shall at least include insurance for physical loss or damage to the Work, temporary buildings, falsework, and materials and equipment in transit, and shall insure against at least the following perils or causes of loss: fire, lightning, extended coverage, theft, vandalism, malicious mischief, earthquake, collapse, debris removal, demolition occasioned by enforcement of Laws and Regulations, water damage (other than caused by flood), and such other perils or causes of loss as may be specifically required by Supplementary Conditions until Final Completion and Acceptance of the Project. Such policy of insurance shall contain at least the following sub-limits of insurance and deductibles:

Sub-limits:	
Property in Transit	\$1,000,000
Property in Offsite Storage	\$1,000,000
Plans & Blueprints	\$25,000
Debris Removal	25% of Insured Physical Loss
Delay in Completion / Soft Cost	TBD
Ordinance of Law (Increased Cost of Construction)	\$1,000,000
Flood and Earthquake	TBD – Full Contract Value
Deductibles:	
Flood and Earthquake	\$25,000
Water Damage other than Flood	\$100,000
All other Perils	\$10,000

- B. The County, its elected officials, officers, employees and agents, hereinafter referred to in this article and in the article entitled “Certificates of Insurance” as “the County and its officers” are to be named as additional insured on all policies of insurance except worker’s compensation insurance with no cross suits exclusion. The County and its officers shall be

- included as additional insureds under commercial general liability and commercial umbrella insurance, for liabilities arising out of both the ongoing and completed operations of Contractor. Such additional insured coverage shall be endorsed to Contractor's policy by attachment of ISO Additional Insured Endorsement forms CG 20 10 10 01 (ongoing operations) and CG 20 37 10 01 (products-completed operations), or form(s) providing equivalent coverage.
- C. All coverages required of the Contractor will be primary over any insurance or self-insurance program carried by the County.
 - D. If the Contractor is a joint venture involving two (2) or more entities, then each independent entity will satisfy the limits and coverages specified here or the joint venture will be a named insured under each respective policy specified.
 - E. In addition to procuring and maintaining commercial general liability insurance, automobile liability and commercial umbrella insurance, for the Contract Term, Contractor shall continue to procure and maintain the products-completed operations liability insurance coverage and commercial umbrella insurance after the Work is substantially complete for the entire Contract Term or for the applicable five-year statutory limitation, whichever is greater. For such period of time, all terms and conditions of such coverage shall remain unchanged, including the limits specified herein and the requirement to provide the County with coverage as an additional insured.
 - F. Contractor agrees to waive all rights of subrogation and other rights of recovery against the County and its officers and shall cause each Subcontractor to waive all rights of subrogation for all coverage.
 - G. Failure of the County to demand such certificate or other evidence of full compliance with these insurance requirements or failure of the County to identify a deficiency from evidence provided will not be construed as a waiver of the Contractor's obligation to maintain such coverage.

- H. Contractor understands and agrees that the purchase of insurance in no way limits the liability of the Contractor.

CERTIFICATES OF INSURANCE

- A. Certificates shall state that the policy or policies shall not expire, be cancelled or altered without at least sixty (60) days prior written notice to the County. Policies and Certificates of Insurance listing the County and its officers as additional insureds (except for workers' compensation insurance) shall conform to all terms and conditions (including coverage of the indemnification and hold harmless agreement) contained in this Contract.
- B. The Contractor agrees to name the County and its officers as additional insured on the commercial general liability insurance, using the ISO Additional Insured Endorsement forms CG20101001 (ongoing operations) and CG20371001 (products-completed operations) forms, or form(s) providing equivalent coverage.
- C. Certificates of Insurance must contain the policy number, policy limits, and policy expiration date of all policies issued in accordance with this Contract; the location and operations to which the insurance applies. Certificates must be provided annually for the duration of the project. If applicable, a specific statement must be included that blasting coverage is included to the extent such risk is present; that Contractor's protective coverage applies to any Subcontractor's operations; and Contractor's contractual liability insurance coverage applies to any Subcontractor.
- D. This insurance for the County as the additional insured shall be as broad as the coverage provided for the named-insured Contractor. It shall apply as primary insurance before any other insurance or self-insurance, including any deductible, non-contributory, and waiver of subrogation provided to the County as the additional insured.
- E. The Contractor shall be wholly responsible for securing certificates of insurance coverage as set forth above from all Subcontractors who are engaged in the Work.

- F. If the County shall so request, the Contractor will furnish the County for its inspection and approval such policies of insurance with all endorsements, or confirmed specimens thereof certified by the insurance company to be true and correct copies.

- G. Contractor shall be responsible and have the financial wherewithal to cover any deductibles or retentions included on the certificate of insurance.

- H. Such certificates should be sent to the County and must identify the “Certificate Holder” as follows:

DeKalb County, Georgia
Director of Purchasing & Contracting
The Maloof Center
1300 Commerce Drive, 2nd Floor
Decatur, Georgia 30030

OWNER CONTROLLED INSURANCE PROGRAM (OCIP)

OCIP Insurance Coverage: In connection with the Work, and for the Contractor and those subcontractors deemed eligible by the County for participation, the County will implement an Owner Controlled Insurance Program (“OCIP”), providing certain insurance coverages as detailed herein. The insurance coverages provided by the OCIP apply only to the Work performed on the Project site. The Contractor and its Subcontractors shall provide their own insurance for all off-site activities. The Contractor’s Risk/All Risk Property Insurance component of the OCIP will expressly exclude coverage on Contractor’s and Subcontractors’ machinery, tools, and equipment not destined to become a part of the Project Work.

OCIP Manual of Insurance Procedures: The OCIP coverage provided by the County shall be further detailed in, and the Contractor requirements with respect to the OCIP shall be described in, the General Liability Wrap-up Manual (“the Manual”) to be incorporated into the Contract Documents and to be issued via an Exhibit to the Contract. This Manual Includes information on the following OCIP coverages: Commercial General Liability, Excess Liability, and Builder’s Risk/All Risk Property Insurance.

RIGHTS RESERVED

The County reserves the right to reject any or all Bids, to waive informalities, and to re-advertise. The County reserves the right to decide which Bid will be deemed lowest, responsive and responsible.

For consideration as a responsible Bidder, the proposed Bidder shall, among other qualifications, demonstrate in its Bid that it has engaged in construction and successful completion of facilities of similar character and magnitude, and shall demonstrate the financial ability to perform the required Work. Bidder may be required to submit evidence setting forth qualifications which entitle him to consideration as a responsible Bidder. A list of work of similar character successfully completed within the last (10) years may be required as set forth in the Invitation to Bid giving the location and size of each project. Bidder shall complete the Reference and Release Form attached to the Bidder Document Package. In addition, the Bidder shall submit upon request by the County, a list of equipment available for use on this Work with its Bid. Any additions, conditions, limitations, or provisions attached to the Bid shall render it informal and will be cause for rejection as non-responsive. No Bid may be revoked or withdrawn until ninety (90) days after the time set for opening the Bids.

AWARD OF CONTRACT

The Contract, if awarded, will be awarded to that responsible Bidder whose responsive Bid will be most advantageous to the County, price and other factors considered. The County is entitled to make the determination in its sole discretion. The Contract between the County and the Contractor shall be executed in the form attached to the Bid Document Package and shall form a binding contract between the contracting parties. A Performance Bond and a Payment Bond, each equal to 100% of the Contract Price, must be provided by the successful Bidder, issued in proper form by a surety company licensed to write bonds in the State of Georgia, listed in the most current U.S. Treasury Circular No. 570, and which has a current A.M. Best rating of "A" (Excellent) with a Financial Size Category of XII or better. Bonds given shall meet the requirements of the law of the State of Georgia including, but not limited to, O.C.G.A. §13-10-1 and §36-91-21 *et seq.*

FAILURE TO EXECUTE CONTRACT

The County shall have ninety (90) days after the time set for openings of Bids to notify a Bidder of the County's acceptance of the Bid and its intent to award the Contract to such Bidder. If the County so notifies a Bidder and the Bidder fails to enter into the Contract in the form attached to the Bid Document Package within ten (10) days of receiving such notice, or fails within that time to provide the required Payment and Performance Bonds and proof of required insurance, the amount of the Bid Bond or other Bid Guarantee shall be paid over to the County as liquidated damages. The acceptance of the payment of the Bid Bond shall not operate to bar any claim the County might otherwise have against the Bidder, and the County shall be authorized to pursue any claim against the Bidder for failure to consummate the Contract as may be authorized by law.

TIME AND LIQUIDATED DAMAGES

Construction must begin within ten (10) days from the date the Contractor acknowledges receipt of the Notice to Proceed, by signing and inserting the acknowledgement date on the Notice to Proceed. Contractor shall fully complete the Work within Five Hundred Seventy-seven (577) days from and including the acknowledgement date. Substantial Completion of the contract is Five Hundred Forty-seven (547) days after the Notice to Proceed. For failure to complete the Work within this period, the Contractor shall pay the County liquidated damages in the amount of One Thousand Dollars (\$1,000.00) for Substantial Completion. Liquidated damages in the amount of One Thousand Five Hundred Dollars (\$1,500.00) for Final Completion will be paid each day in excess of the Contract Time unless an extension of the Contract Time has been obtained by Change Order, as defined in the Contract, prior to the expiration of the Contract Term as defined in the Contract. Should the Generator Acceptance Tests indicate that the generator performance falls outside of the requirements of the test standard, liquidated damages as deemed by the Owner shall be applied at One Thousand Dollars (\$1,000.00) each day. No disruption of the existing operations will exceed more than 3 (three) hours on any day. This time will not include for isolation and purging of headers/tie in points, which will be done in liaison with the operational staff at the Plant. The Contractor shall pay the County liquidated damages in the amount of One Thousand Dollars (\$1,000.00) per hour or any portion thereof for any period longer than 3 (three) hours.

LOCATIONS AND SITE

The site of the proposed Work is at the stated location(s) within DeKalb County, Georgia. By submitting a Bid, the Bidder accepts the site in its present condition and agrees, if awarded the Contract, to carry out all Work in accordance with the requirements of the Contract, the Specifications and as shown on the Drawings. The Bidder shall, before submitting a Bid, visit the site and acquaint itself with the actual conditions and the location of any or all obstructions that may exist on the site. The documents comprising the Contract contain the provisions required for the completion of the Work to be performed pursuant to this Contract. Information obtained from an officer, agent, or employee of the County, or any other person shall not affect the risks or obligations assumed by the Contractor or relieve it from fulfilling any of the conditions of the Contract. Each Bidder, prior to submitting his Bid, is responsible for inspecting the site and for reading and being thoroughly familiar with all of the documents comprising the Contract and Bid Document Package. The failure or omission of any Bidder to so familiarize himself shall in no way relieve any Bidder from any obligation in respect to his Bid. The Contractor shall inspect all easements and rights-of-way to ensure that the County has obtained all land and rights-of-way necessary for completion of the Work to be performed pursuant to the Contract. The Contractor shall comply with all stipulations contained in easements acquired by the County. If applicable to the Work, all easements and rights-of-way documents are available for inspection in the office of The Department of Watershed. The Contractor shall not be entitled to damages and agrees not to make any claim against the County, its officials or employees for the failure to obtain necessary interests in land for this Project. The Contractor shall accurately locate above-ground and below-ground utilities and structures which may be affected by the Work using whatever means may be appropriate.

DEKALB FIRST LOCAL SMALL BUSINESS ENTERPRISE (LSBE) ORDINANCE

It is the objective of the Chief Executive Officer and Board of Commissioners of DeKalb County to provide maximum practicable opportunity for all businesses to participate in the performance of government contracts. The current DeKalb County List of Certified Vendors may

be found in the left column under the name *LSBE Certified Vender List* on the County website at <http://www.dekalbcountyga.gov/purchasing>.

It is required that all responding Bidders attend the mandatory LSBE meeting within two-weeks of the solicitation's advertisement, and comply, complete and submit all LSBE forms with the Bidder's response in order to remain responsive. Attendance can be in person, via video conference and teleconference. Video conferencing is available through Skype/Lync. Instructions for attendance via video conference can be found on the County's website at <https://www.dekalbcountyga.gov/purchasing-contracting/dekalb-first-lsbe-program>.

For further details regarding the DeKalb First Local Small Business Enterprise Ordinance, contact the LSBE Program representative at pcadmin-ops@dekalbcountyga.gov or (404) 371-7051.

FEDERAL WORK AUTHORIZATION PROGRAM PARTICIPATION

All qualifying Contractors and Subcontractors performing work with DeKalb County, Georgia must register and participate in the federal work authorization program to verify the work eligibility information of new employees. In order for a Bid to be considered, it is mandatory that the Bidder's Affidavit of Compliance with O.C.G.A. §13-10-91 be completed and submitted with the Bid.

GEORGIA OPEN RECORDS ACT

Without regard to any designation made by the person or entity making a submission, DeKalb County considers all information submitted in response to this invitation or request to be a public record that will be disclosed upon request pursuant to the Georgia Open Records Act, O.C.G.A. §50-18-70 et seq., without consulting or contacting the person or entity making the submission, unless a court order is presented with the submission. You may wish to consult an attorney or obtain legal advice prior to making a submission.

FIRST SOURCE JOBS ORDINANCE

The DeKalb County First Source Jobs Ordinance requires contractors or beneficiaries entering into any type of agreement with the County, including purchase orders, regardless of what they may be called, for the procurement or disposal of supplies, services, construction projects, professional or consultant services, which is funded in whole or part with County funds or County administered funds in which the contractor is to receive \$50,000 or more in County expenditures or committed expenditures and recipient of urban redevelopment action grants or community development block funds administered in the amount of \$50,000 or more make a good faith effort to hire DeKalb County residents for at least 50% of jobs using the First Source Registry (candidate database). The work to be performed under this contract is subject to the provisions of the DeKalb County First Source Jobs Ordinance. Please complete the First Source Jobs Ordinance Acknowledgement and New Employee Tracking Form found within the First Source Jobs Ordinance information with Exhibits 1 - 4 and submit with the bid.

For more information on the First Source Jobs Ordinance requirement, please contact WorkSource DeKalb at www.worksourcedekalb.org or 404-687-3400.

ETHICS RULES

Bidders are subject to the Ethics provision within the DeKalb County Purchasing Policy; the Organizational Act, Section 22A, the Code of DeKalb County; and the rules of Executive Order 2014-4. Any violations will be addressed, pursuant to these policies and rules.

To the extent that the Organizational Act, Section 22A, the Code of DeKalb County, and the rules of Executive Order 2014-4 allow a gift, meal, travel expense, ticket, or anything else of value to be purchased for a CEO employee by a contractor doing business with the County, the contractor must provide written disclosure, quarterly, of the exact nature and value of the purchase to the Chief Integrity Officer, if created, or the Finance Director or his/her designee. Every contractor conducting business with the County will receive a copy of these ethical rules at the time of execution of the contract.

COOPERATIVE PROCUREMENT

The County through the Department of Purchasing and Contracting may permit piggybacks to this contract from other city, county, local authority, agency, or board of education if the vendor will

extend the same prices, terms, and conditions to the governmental entity. Piggybacking shall only be available where competition was used to secure the contract and only for a period of 12-months following entry, renewal or extension of the contract. This provision shall not apply to any contract where otherwise prohibited or mandated by state law.

RIGHTS RESERVED - AWARDS

The County reserves the right to make one (1) award or multiple awards.

STANDARD COUNTY CONTRACT

The attached sample contract is the County's standard contract document, which specifically outlines the contractual responsibilities. All bidders should thoroughly review the document prior to submitting a bid. Any proposed revisions to the terms or language of this document must be submitted in writing with vendor questions no later than the date and time listed in the bid timetable. Since proposed revisions may result in a bid being rejected if the revisions are unacceptable to the County, bidders should review any proposed revisions with an officer of the firm having authority to execute the contract. No alterations can be made in the contract after award by the Board of Commissioners.

ATTACHMENT A

SCOPE OF WORK

- A. Contractor shall provide services to design, supply, install and commission two new ozone generators, including all supporting components, to operate in parallel with two existing generators at Scott Candler Water Treatment Plant (SCWTP). One new generator will be installed in an open space, while the other will be installed by removing an existing generator.
- B. The Contractor shall be responsible for the design of the ozone generators in accordance with the applicable design standards and requirements set forth herein. The Contractor shall ensure that the Project is built timely as designed and to specifications. The design and specifications shall adhere to the design standards and requirements set forth in the Project Technical Criteria, DeKalb County Department of Watershed Management Design Standards, Potable Water Main, Gravity Sanitary Sewer, and Sanitary Sewer and Force Main Design Standards (2017 Edition or Latest Edition). DeKalb County Standard Specifications and all other local, State, and federal requirements of Governmental Authority.
- C. The Contractor shall prepare drawings, specifications and supporting documentation to obtain all approvals necessary to construct the Project. The Contractor shall complete all Facilities as required by this ITB, including all labor, materials and equipment. Unless otherwise specified, the Contractor shall furnish or caused to be furnished and assume full responsibility for materials, equipment, labor, transportation, construction equipment and machinery, tools, appliances, fuel, power, light, heat, water, sanitary facilities, temporary facilities and all other facilities and incidentals necessary for completion of the Project.
- (1) Project Location: The Work will take place at the Scott Candler Water Treatment Plant in DeKalb County, GA.
 - (2) Work Coordination: The Contractor shall coordinate execution of the Work with subcontractors, other contractors working on related County projects, and the County, as required, to maintain operation of the existing facilities and satisfactory progress of the Work.
 - (3) Site Conditions: The Contractor shall make all necessary investigations to determine the existence and location of underground utilities and surface impacts that may be caused due to assessment activities. The Contractor will be held responsible for any

damage to and for maintenance and protection of existing utilities, structures, and personal property. Nothing in these Contract Documents shall be construed as a guarantee that utilities are not located within the areas of operation.

The scope of the work consists of, but is not necessarily limited to, the following:

- a. Review all existing as-built drawings and visit the site to confirm the dimensions of pipelines, pressure ratings of pipes and fittings, grades, top and bottom water levels in the contact zones, cooling water, oxygen and nitrogen supply pressures and quality (concentration) and ozone delivery pressures required;
- b. Review and confirm the capacity of the existing electrical supply, including all conduits, cables, transformers, switchgear, Power Supply Units (PSUs), space availability and the ability to accommodate the proposed new ozone generators and related electrical equipment;
- c. Propose two new ozone generators to run in parallel with the existing functioning generator and calculate flows and pressures, and how the new generators will be integrated into the operations of the existing generators and the standard operating procedures for Scott Candler Water Treatment Plant (SCWTP);
- d. Confirm the acceptability of the existing generators to operate in parallel with the new generators, and report on and make improvements as necessary, including the capacity of the liquid oxygen supply, ozone contactors, and ozone destruct systems;
- e. Design, manufacture, deliver and install the two new generators and supporting equipment, including a new closed loop cooling system;
- f. Design, manufacture, deliver and install the new PSUs for the generators and associated switchgear and Motor Control Center (MCC) components, taking

into consideration the integration thereof within the existing electrical MCCs while keeping the Plant operational;

- g. Integrate the new and existing PSUs, MCCs and associated instrumentation for the entire ozone generation system, including but not limited to the liquid oxygen supply, nitrogen boost, ozone generation, ozone contactors, ozone destruct, and cooling water systems (including new closed loop system), into a new Control Logix/Compact (PLC) with latest compatible software version at the time of implementation (including all programming and with redundancy on the master PLC) and into the facility's existing Factory Talk Supervisory Control and Data Acquisition (SCADA) System. All existing Siemens PLC hardware will be removed and replaced with Allen Bradley. The Scott Candler WTP predominately utilizes Allen Bradley/Rockwell Automation hardware and software. As the Plant and its process and controls system is wide spread throughout the Plant and Distribution System, staff has standardized these systems and focused on training specific to Allen Bradley/Rockwell Automation products. Allen Bradley has proven reliability and standardizing installation of process equipment would allow for sustained commitment necessary to preserve an efficient automation system. Communication with new equipment will use Ethernet Industrial Protocol (IP) where available;
- h. All PLC and Human Machine Interface (HMI) programming will be performed with Rockwell's Allen-Bradley software for integration into current system, and in coordination with DWM Operations and Maintenance staff;
- i. Verify the status (and report on any deficiencies) of all existing ozone generator-related control instruments and design, manufacture and install the associated instrumentation and electrical equipment for the new generators, including detailed process and instrumentation diagrams (P&IDs) and the control philosophy, taking into consideration the integration with the existing ozone generation equipment;

- j. Design and construct all civil/structural work required for installation of the new ozone equipment, and stamped by a Georgia Professional Engineer (PE);
- k. Remove and dispose/salvage (confirm with DWM Operations staff) one dysfunctional generator, PSU, instrumentation, cabling, piping and associated fittings;
- l. Acceptance Testing and Commissioning of all new equipment in conjunction with the existing equipment;
- m. Submit Operational and Maintenance (O&M) Manuals.
- n. The Contractor will coordinate with the Owner to schedule the work to be performed and down time required to ensure that the existing generator systems remain operational at all times;
- o. Contractor shall provide training to DWM staff as required;
- p. Quality assurance during manufacturing and installation of the work;
- q. Project management and administration during the contract period;
- r. Fix/resolve any warranty issues during the warranty period of two years after final completion.
- s. The ozone generator, electrical equipment and instrumentation installed shall have a design life of at least 25 years, taking into consideration reasonable care and maintenance (as recommended and determined by the manufacturer) during this period. Pipework and valves shall have a design life of 30 years.

All Work shall be performed in accordance with the General Conditions of Contract, all codes, details, specifications and the drawings. The work for this contract must be carefully planned and coordinated with the DWM staff. The Contractor will be required to submit a work plan for approval by the Owner.

In addition to that stated above, the following services shall also be provided by the Contractor:

- a. Develop the Project execution plan, including Project schedule in Primavera P6, by an experienced Scheduler.
- b. Provide warranty coverage documents and contact information in accordance with the contract documents. The Contractor shall provide a two (2) year warranty for engineering, materials and construction defects. The warranty begins after final completion and final acceptance of the work.
- c. Unless otherwise specified, all waste, scrap, debris, etc. resulting from demolition and other activities under this contract, shall become the property of the Contractor and the Contractor shall be responsible for appropriate handling and disposal.

TEAM EXPERIENCE

A. The Contractor shall be fully qualified to complete the work listed in this ITB and shall meet the following experience criteria.

(1) Contractor Experience

Within the past ten (10) years, the Contractor must have successfully designed, procured the equipment for, supplied and installed a minimum of two (2) Ozone Generation Systems of comparable scope of supply and complexity at municipal facilities in the United States and/or Canada. The referenced systems shall have been in successful operation for a minimum of two years within the previous ten (10) years as of this ITB date. Contractor shall have under employment in the United States personnel who have a minimum of five (5) years of experience in servicing and supervising installation and start-up of Liquid Oxygen (LOX) based ozone systems. The experience shall include installation and start-up of at least two (2) facilities with ozone production capacity of not less than 1,800 pounds per day using multiple generators at a minimum ozone product gas concentration of 8% by weight within the last eight (8) years as of the ITB date. The referenced systems shall have been in successful operation for a minimum of two years within the previous ten (10) years as of this ITB date.

The Department of Watershed Management (DWM) prefers equipment and components that are manufactured in the United States as well as the provision of a

local warehouse and access to local technical services representatives. Should items not be locally manufactured, the Contractor shall clearly identify these in their ITB and state how maintenance backup will be provided in the future.

(2) Staff Experience

Project Manager: The Project Manager shall be a full-time employee of the lead-Contractor. Within the past ten (10) years, the Project Manager must have successfully completed at least two (2) projects involving ozone generation in water treatment plants.

(3) Field Engineer and Mechanical Foreman

These individuals shall have at least ten (10) years of experience in their roles. They shall have a thorough understanding of the work involved, of the means and methods and shall oversee that all work under this contract is performed to acceptable professional and technical standards. The lead(s) for each sub-Contractor shall have at least 5 years of experience, if not already included among the personnel listed above.

Bidder shall provide appropriate references and contact information to verify the above. References must have been informed that they are being used as a reference and that DeKalb County may be contacting them. The references shall be someone who has personal knowledge of the Contractor's performance during the referenced project and is available for contact by DeKalb County.

B. CONSTRUCTION SERVICES

1. Comply with all County and industry construction standards and best practices
2. Comply with all environmental mitigation requirements
3. Install the ozone generators and all appurtenances, as described herein and approved by the County.
4. Implement the construction quality control program
5. Contractor shall be responsible for coordinating the Project with any other entity in conjunction with Department of Watershed Management (DWM) personnel
6. Contractor shall be responsible for coordinating and executing any and all utility

relocates with utility owners

7. Contractor provides set of approved Construction Documents
8. Contractor provides all construction supervision, inspection, construction equipment, labor, materials, tools, and subcontracted items to complete the Work
9. Contractor prints and distributes all construction activity notices (based on DWM-approved content and designs) to impacted property/business owners and complies with all laws and ordinances
10. Contractor gives all notices to and complies with all laws and ordinances
11. Contractor submits Schedule of Work for County approval, as basis for management & control of project and progress reports to the County
12. Contractor shall be responsible for all Safety requirements
13. Contractor shall be responsible for all hazardous conditions and/or hazardous materials
14. Contractor shall prepare monthly reports
15. Contractor shall be responsible for daily site maintenance
16. Contractor shall be responsible for material QA/QC testing.
17. Contractor shall provide assistance with County-procured materials, if needed
18. Contractor shall provide as-built drawings

C. COMPLETION & WARRANTIES

1. Substantial Completion is determined when all or portions of the Project are available for County's use and revenue service. Upon approval of substantial completion, partial release of retention is granted.
2. Upon the request of the Contractor, a joint inspection will be scheduled to verify Substantial Completion. Upon verification, a Certificate of Substantial Completion will be issued by the County to the Contractor.
3. Performance testing will be required prior to the commissioning of all equipment.
4. Acceptance of the equipment will be provided by the County.
5. Final Completion will be granted in accordance with the contract specifications.
6. Warranty service is required during Warranty Period per the contract specifications.
7. Warranty Period of 24 months from Final Completion is required per the contract specifications.

Submit All Shop Drawing in A Separate Sealed Envelope

ATTACHMENT B
(Consisting of 3 pages)

BIDDER'S UNIT PRICE FORM

*****NEW-BIDDER'S UNIT PRICE FORM MUST BE SUBMITTED IN A SEPARATE SEALED ENVELOPE OR BIDDER WILL BE DEEMED NON-RESPONSIVE AND WILL NOT BE CONSIDERED FOR AWARD*****

TO: The Governing Authority of DeKalb County, Georgia

The undersigned, as Bidder, declares that he has carefully examined ITB No. 20-101212, Scott Candler Water Treatment Plant - Ozone Generators Design and Installation, an annexed proposed form of Contract, the Specifications therein contained, and the Drawings therein referred to, and that he proposes and agrees that if his Bid is accepted, to provide the necessary machinery, tools, apparatus, and other means of construction, and will furnish all materials and labor specified in the Contract, or called for by the Drawings, or necessary to complete the Work in the manner therein specified within the time specified, as therein set forth for the unit prices on the form following this page.

NOTE TO SUPPLIER:

Note 1: Every line item must be completed to be considered for award.

By signature hereon, the Bidder's authorized agent ("Agent") certifies that all necessary corporate acts have been taken to authorize the Agent to sign this document and that all information provided in Bidder's Unit Price Form is an accurate representation of the information the Bidder's is providing.

Bidder's Name: _____

Signature of Agent: _____

Printed Name: _____

Title: _____

Date: _____

ATTACHMENT B-1**BIDDER'S UNIT PRICE FORM**

ITEM NO.	DESCRIPTION	UNIT	UNIT PRICE	AMOUNT
1.	Design	LS		
2.	Project Management	LS		
3.	Mobilization	LS		
4.	Demobilization	LS		
5.	Miscellaneous Demolition & Removal	LS		
6.	Ozone Generators	EA		
7.	Ozone Generators w/PSU & Ancillary Equipment	LS		
8.	Closed Loop Cooling System	LS		
9.	Civil & Structural Modifications	LS		
10.	Piping & Valves	LS		
11.	Instrumentation & Controls (including Integrator & Factory Acceptance Testing (FAT))	LS		
12.	Electrical to include Factory Acceptance Testing (FAT)	EA		
13.	HVAC Modifications	LS		
14.	Spare Parts per Manufacturer's Recommendations	LS		
15.	O&M Manuals	LS		
16.	Training	LS		
17.	Commissioning & Testing	LS		
18.	Owner's Directed Allowance	LS		\$840,000.00

TOTAL BID:

_____ \$ _____
 (State in words on the line above) (In figures)

These quantities are approximate and may be increased or decreased as to any and all units as necessary to complete the construction of said Project without entitling the Contractor to any claim

for extra compensation because of any injury, damage or delay he may sustain on account of such increase or decrease. The Contractor shall be entitled to compensation on the foregoing unit prices only on the quantities of materials actually furnished and work actually done as determined and approved in writing by the County through an inspection of the work completed. In no event shall the County be liable for payment in excess of the total Bid without proper prior written authorization via Change Order from the County. The Total Bid includes and encompasses the cost of all labor, materials, equipment, tools, supervision, scheduling, safety program, coordination, engineering, testing, surveys, layout, cleanup, and other things and services required to complete the entire Project in strict conformity with the Drawings, Specifications, the Contract, and all addenda and authorized written clarifications issued prior to the Bid date. Without limitation, the Total Bid also includes all applicable sales and use taxes, fees, temporary lighting, security for the site, heating and cooling, temporary utilities, freight costs, handling costs, permit costs, field and main office costs, bond premiums, insurance premiums, direct and indirect administrative costs, overhead, and profit.

Bidder has examined the site of the proposed Work and all documents comprising the Contract and is satisfied as to the conditions to be encountered in performing the work and as to the requirements of the Contract.

The Contractor shall include in his bid the total cost to:

1. Perform all necessary civil and structural modifications and remove and properly dispose of all redundant equipment and material from the site including, but not limited to, the old generator with all appurtenances, building rubble, concrete and old electrical wires/conduits. All equipment removed, including generator, PSU, pipework and valves, shall be disposed of by the Contractor and a salvage value offered as part of the bid price. All steel reinforcing and holding down bolts remaining above the concrete grade shall be cut off at least two inches below the surface of the concrete, and the holes shall be filled with a non-shrink concrete repair mortar, and the floor covering made good.
2. Structurally strengthen the generator floor to accommodate the additional loads from the new generators and appurtenances, based on the Contractor's calculations as required. The cost will also include cost for any surveys and testing that will be required to determine the extent of the current reinforcing and concrete characteristics.
3. Demolition activities shall be performed in accordance with the Technical Specifications.
4. Core new holes through the concrete slab or walls, close unused holes and restore all paintwork, including the epoxy floors, of the entire generator room.
5. Put in place the necessary protection measures to connect pipework using materials (i.e., isolation kits, cathodic protection, etc.) to ensure that no galvanic corrosion occurs. The cost of these measures will be deemed to be included in the total cost.

No Bid may be revoked or withdrawn until ninety (90) days after the time set for opening the Bids.

ATTACHMENT C
(Consisting of 4 pages)

BID BOND ACKNOWLEDGEMENT AND BID BOND FORM

BID BOND ACKNOWLEDGEMENT

Attached hereto is Bid Bond made by _____
_____, a surety company listed in the most recent US Treasury Circular No. 570 and licensed to write surety bonds in the State of Georgia, payable to DeKalb County, Georgia (or an official bank check), in the amount of ten percent (10%) of the Bid.

If this Bid shall be accepted by DeKalb County and the undersigned shall fail to execute a satisfactory contract in the form of said proposed Contract, give satisfactory Performance and Payment Bonds, or furnish satisfactory proof of the insurance required, as stated in the Instructions to Bidders within ten (10) days from the Notice of Award of the Contract, then the County may at its option, determine that the undersigned abandoned the Contract and thereupon this Bid shall be null and void, and the sum stipulated in the attached Bid Bond (or an official bank check) shall be forfeited to the County as liquidated damages.

Bidder declares his intent to subcontract the portion of the Work as below stated. Bidder understands and agrees that the use of any Subcontractor not listed below shall be strictly prohibited without prior written approval from the County. *(List names of all subcontractors and the work to be provided by the subcontractor on the lines provided below.)*

Bidder further declares that the full names and residence addresses of all persons and parties interested in the foregoing Bid as principals are as follows:

Bidder declares further that it is / is not a DeKalb County Firm.

Signed, sealed, and dated this _____ day of _____, 20____.

By: _____ (SEAL)
Signature

Print Name of Signer

Title of Signer

Name of Business Entity Submitting Bid

Bidder's Street Address

Bidder's City, State and Zip Code

Bidder's Phone Number

Bidder's Fax Number

Bidder's E-Mail Address

ATTACHMENT C-1

BID BOND FORM

KNOW ALL MEN BY THESE PRESENTS, that we, _____

_____ (hereinafter called the Principal) and _____

_____ (hereinafter called the Surety), a corporation chartered and existing under the laws of the State of _____ with its principal offices in the City of _____ and listed in the Federal Register and licensed to write surety bonds in the State of Georgia, are held and firmly bound unto DeKalb County, Georgia, in the full and just sum of 10% of the Principal's Bid good and lawful money of the United States of America, to be paid upon demand of DeKalb County, Georgia, to which payment well and truly to be made we bind ourselves, our heirs, executors, administrators, and assigns, jointly and severally and firmly by these presents.

WHEREAS, the Principal is about to submit, or has submitted to DeKalb County, Georgia, a Bid for **Scott Candler Water Treatment Plant – Ozone Generators Design and Installation**

WHEREAS, the Principal desires to file this Bond in accordance with law to accompany this Bid.

NOW, THEREFORE, the conditions of this obligation are such that if the Bid be accepted within ninety (90) days of the Bid opening, the Principal shall execute a Contract in accordance with the Bid and upon the terms, conditions, and prices set forth therein, and in the form and manner required by DeKalb County, Georgia, and within ten (10) days from the date of Notice of Award of the Contract, execute a sufficient and satisfactory Performance Bond and Payment Bond payable to DeKalb County, Georgia, each in an amount of one hundred percent (100%) of the total Contract Price, in form and with security satisfactory to DeKalb County and furnish satisfactory proof of the insurance required, then this obligation to be void; otherwise, to be and remain in full force and virtue in law; and the Surety shall, upon failure of the Principal to comply with any or all of the foregoing requirements within the time specified above,

immediately pay to the aforesaid DeKalb County, Georgia, upon demand, the amount hereof in good and lawful money of the United States of America, not as a penalty, but as liquidated damages.

IN TESTIMONY THEREOF, the Principal and Surety have caused these presents to be duly signed and sealed this day of _____, 20_____.

PRINCIPAL

By: _____(SEAL)
Signature of Principal

Print Name and Title of Authorized Signer

Print Name of Principal Business

ATTEST:

Corporate Secretary

SURETY

By: _____(SEAL)
Signature of Surety (by Power of Attorney)

Print Name and Title of Authorized Signer

Print Name of Surety Business

WITNESS

[Attach Original Power of Attorney]

ATTACHMENT D
(Consisting of 11 pages)

**DEKALB FIRST LSBE INFORMATION
WITH EXHIBITS 1 – 2**

**SCHEDULE OF LOCAL SMALL BUSINESS ENTERPRISE PARTICIPATION
OPPORTUNITY TRACKING FORM**

The Chief Executive Officer and the Board of Commissioners of DeKalb County believe that it is important to encourage the participation of small and local businesses in the continuing business of County government; and that the participation of these types of businesses in procurement will strengthen the overall economic fabric of DeKalb County, contribute to the County’s economy and tax base, and provide employment to local residents. Therefore, the Chief Executive Officer and the Board of Commissioners have made the success of local small businesses a permanent goal of DeKalb County by implementing the DeKalb First Local Small Business Enterprise Ordinance.

PROVISIONS OF DEKALB FIRST LOCAL SMALL BUSINESS ENTERPRISE (LSBE)
ORDINANCE

Percentage of LSBE Participation Required
20% of Total Award

Certification Designation	Request For Proposals (RFP)
LSBE Within DeKalb (LSBE-DeKalb)	Ten (10) Preference Points
LSBE Outside DeKalb (LSBE-MSA)	Five (5) Preference Points
Demonstrated GFE	Two (2) Preference Points

Certified Local Small Business Enterprises (LSBEs) located within DeKalb County and prime contractors utilizing LSBEs that are locally-based inside DeKalb County shall receive ten (10) points in the initial evaluation of their response to any Request for Proposal. Certified LSBEs located outside of DeKalb County but within the nine (9) County Metropolitan Statistical Area (MSA) consisting of Cherokee, Clayton, Cobb, Douglas, Fayette, Fulton, Gwinnett, Henry and Rockdale Counties shall receive five (5) points in the initial evaluation of their response to any Request for Proposal. Prime Contractors who demonstrate sufficient good faith efforts in accordance with the requirements of the ordinance shall be granted two (2) points in their initial evaluation of responses to any Request for Proposal. Pro-rated points shall be granted where a mixture of LSBE-DeKalb and LSBE MSA firms are utilized. Utilization of each firm shall be based upon the terms of the qualified sealed solicitation.

Prime Contractor(s) deemed responsible and remains responsive to an Invitation to Bid (ITB) because they are either a certified LSBE-DeKalb or LSBE-MSA firm or has obtained 20% participation of an LSBE-DeKalb or LSBE-MSA firm, submits the lowest bid price shall be deemed the lowest, responsive and responsible bidder.

Prime Contractor(s) deemed responsible and remains responsive to an Invitation to Bid (ITB) and documented good faith efforts, submits a lower bid price than a Prime Contractor that achieved 20% LSBE participation, or otherwise required benchmark, then the Prime Contractor who actually met the benchmark will be given the opportunity to match the lowest bid price of the Prime Contractor who

only made good faith efforts. Prime Contractor(s) who choose **not** to match the lowest bid price, then the Prime Contractor who made the good faith efforts will be deemed the lowest, responsive and responsible bidder.

For all qualified sealed solicitations, the Director of Purchasing and Contracting, DeKalb County Government, shall determine if the bidder/proposer has included written documentation showing that at least twenty percent (20%) of the total contract award will be performed by a certified LSBE. This written documentation shall be in the form of a notarized Schedule of LSBE Participation (Attached hereto as “Exhibit 1”.) For all contracts, a signed letter of intent from all certified LSBEs describing the work, material, equipment and/or services to be performed or provided by the LSBE(s) and the agreed upon percentage shall be due with the bid or proposal documents and included with “Exhibit 1”. The certified vendor list establishes the group of Certified LSBE’s from which the bidder/proposer must solicit subcontractors for LSBE participation. This list can be found on our website <http://www.dekalbcountyga.gov/purchasing-contracting/about-purchasing-and-contracting> or obtained from the Special Projects LSBE Program team.

Prime Contractors failing to meet the LSBE benchmark must document and demonstrate Good Faith Efforts in accordance with the attached “Checklist for Good Faith Efforts” portion of “Exhibit 1.” The notarized Schedule of LSBE Participation shall be due and submitted with each bid or proposal. Failure to achieve the LSBE benchmark or demonstrate good faith efforts shall result in a bid or proposal being rejected. Prime Contractors that fail to attend the mandatory LSBE meeting in person or via video conference shall mean that the Prime Contractor has not demonstrated sufficient good faith efforts and its bid or proposal if submitted, shall be deemed non-responsive without any further review.

Upon award, Prime Contractors are required to submit a report detailing LSBE Sub-Contractor usage with each request for payment and not less than on a monthly basis. Prime Contractors shall ensure that all LSBE sub-contractors have been paid within seven (7) days of the Prime’s receipt of payment from the County. Failure to provide requested reports/documentation shall constitute a material breach of contract, entitling the County to terminate the Contract for default or pursue other remedies. LSBE sub-contractors must confirm payments received from the Prime(s) for each County contract they participate in.

For eligible bids/proposals valued over \$5,000,000.00, the Mentor-Protégé provision of the Ordinance shall apply. Prime Contractors must agree to become mentors and take on an LSBE protégé in an effort to enhance the potential of future LSBEs. Qualifying projects shall be performed by both Mentor and Protégé through a subcontract between both parties. This requirement is in addition to all other applicable sections of the DeKalb First Ordinance. Please review the ordinance, section 2-214 or contact the LSBE Program Representative for detailed information regarding this initiative.

EXHIBIT 1

SCHEDULE OF DEKALB FIRST LOCAL SMALL BUSINESS ENTERPRISE PARTICIPATION

OPPORTUNITY TRACKING FORM

As specified, Bidders and Proposers are to present the details of LSBE participation below:

PRIME BIDDER/PROPOSER _____

SOLICITATION NUMBER: **20-101212**

TITLE OF UNIT OF WORK: **Scott Candler Water Treatment Plant – Ozone Generators Design and Installation**

1. My firm, as the prime bidder/proposer on this unit of work, is a certified (check all that apply):
 _____ LSBE-DeKalb _____ LSBE-MSA

2. If you are a Certified LSBE-DeKalb or MSA, please indicate below the percentage of that your firm will carry out directly: _____.

3. If the prime bidder/proposer is a joint venture, please describe below the nature of the joint venture and level of work and percentage of participation to be provided by the LSBE-DeKalb or MSA joint venture firm.

4. List the LSBE-DeKalb or MSA subcontractors and/or firms (including suppliers) to be utilized in of this contract, if awarded. No changes can be made in the subcontractors listed below without the prior written approval of the County. Please attach a signed letter of intent from all certified LSBEs describing the work, materials, equipment or services to be performed and/or provided and the agreed upon percentage of work to be performed. A Letter of Intent form is attached hereto as “Exhibit 2”.

Name of Company	
Address	
Telephone	
Fax	
Contact Person	
Indicate certification status and attach proof of certification: LSBE-DeKalb/LSBE-MSA	
Description of services to be performed	
Percentage of work to be performed	

Name of Company	
Address	

Telephone	
Fax	
Contact Person	
Indicate certification status and attach proof of certification: LSBE-DeKalb/LSBE-MSA	
Description of services to be performed	
Percentage of work to be performed	

Name of Company	
Address	
Telephone	
Fax	
Contact Person	
Indicate certification status and attach proof of certification: LSBE-DeKalb/LSBE-MSA	
Description of services to be performed	
Percentage of work to be performed	

Name of Company	
Address	
Telephone	
Fax	
Contact Person	
Indicate certification status and attach proof of certification: LSBE-DeKalb/LSBE-MSA	
Description of services to be performed	
Percentage of work to be performed	

Please attach additional pages, if necessary.

EXHIBIT 1, CONT'D

DEKALB COUNTY
CHECKLIST FOR GOOD FAITH EFFORTS

A bidder/proposer that does not meet the County’s LSBE participation benchmark is required to submit documentation to support all “Yes” responses as proof of “good faith efforts.” Please indicate whether or not any of these actions were taken:

	Yes	No	Description of Actions
1.			Prime Contractors shall attend a MANDATORY LSBE Meeting in person or via video conference within two-weeks of advertisement of the solicitation.
2.			Provide a contact log showing the company’s name, contact person, address, email and contact number (phone or fax) used to contact the proposed certified subcontractors, nature of work requested for quote, date of contact, the name and title of the person making the effort, response date and the percentage of work.
3.			Provide interested LSBEs via email, of any new relevant information, if any, at least 5 business days prior to submission of the bid or proposal.
4.			Efforts made to divide the work for LSBE subcontracting areas likely to be successful and to identify portions of work available to LSBEs consistent with their availability. Include a list of divisions of work not subcontracted and the corresponding reasons for not including them. The ability or desire of a bidder/proposer to perform the contract work with its own organization does not relieve it of the responsibility to make good faith efforts on all scopes of work subject to subcontracting.
5.			Efforts were made to assist potential LSBE subcontractors meet bonding, insurance, or other governmental contracting requirements. Where feasible, facilitating the leasing of supplies or equipment when they are of such a specialized nature that the LSBE could not readily and economically obtain them in the marketplace.
6.			Communication via email or phone with DeKalb First Program Staff seeking assistance in identifying available LSBEs. Provide DeKalb First Program Staff representative name and title, and date of contact.
7.			For all contracts, a signed letter of intent from all certified LSBEs describing the work, materials, equipment or services to be performed or provided by the LSBE(s) and the agreed upon LSBE participation percentage shall be due with the bid or proposal documents.
8.			Other Actions, to include Mentor/Protégé commitment for solicitations \$5M and above (specify):

Please explain all “no” answers above (by number):

This list is a guideline and by no means exhaustive. The County will review these efforts, along with attached supporting documents, to assess the bidder/proposer's efforts to meet the County's LSBE Participation benchmark. If you require assistance in identifying certified, bona fide LSBEs, please contact the Purchasing and Contracting Department - DeKalb First Program, Felton Williams, Procurement Projects Manager at 404-371-6312.

EXHIBIT 1, CONT'D**DEKALB FIRST LOCAL SMALL BUSINESS ENTERPRISE SCHEDULE OF PARTICIPATION OPPORTUNITY TRACKING FORM****Bidder/Proposer Statement of Compliance**

Bidder(s)/Proposer(s) hereby state that they have read and understand the requirements and conditions as set forth in the objectives and that reasonable effort were made to support the County in providing the maximum practicable opportunity for the utilization of LSBEs consistent with the efficient and economical performance of this contract. The Bidder and any subcontractors shall file compliance reports at reasonable times and intervals with the County in the form and to the extent prescribed by the Director of DeKalb County Purchasing and Purchasing and Contracting Department. Compliance reports filed at such times as directed shall contain information as to the employment practices, policies, programs and statistics of Contractors and their subcontractors.

1. Non-Discrimination Policy

- a. During the performance of this agreement, Contractor agrees to conform to the following Non-Discrimination Policy adopted by the County.
- b. Contractor shall not discriminate against any employee or applicant for employment because of race, color, religion, sex, national origin, or disability. The Contractor will take action to ensure that applicants are employed, and the employees are treated during employment without regard to their race, color, religion, sex, national origin, or disability. Such action shall include, but not be limited to, the following:
 - (1) Employment, upgrading, demotion or transfer; recruitment or recruitment advertising; layoff or termination; rates of pay or other forms of compensation; and selection for training, including apprenticeship. Contractor agrees to post in conspicuous places available to employees and applicants for employment, notices to be provided setting forth provisions of this non-discrimination clause.
 - (2) Contractor shall, in all solicitations or advertisements for employees placed by or on behalf of Contractor, state that all qualified applicants will receive consideration for employment without regard to race, color, religion, sex, national origin, or disability.
- c. Without limiting the foregoing, Contractor shall not discriminate on the basis of disability in the admission or access to, or treatment or employment in, the programs and activities, which form the subject of the contract. The Contractor will take action to ensure that applicants for participation in such programs and activities are considered without regard to disability. Such action shall include, but not be limited to, the following:
 - (1) Contractor agrees to post in conspicuous places available to participants in its programs and activities notices to be provided setting forth the provisions of this non-discrimination clause.

- (2) Contractor shall, in all solicitations or advertisements for programs or activities, which are the subject of the contract, state that all qualified applicants will receive consideration for participation without regard to disability.

2. **Commitment**

The undersigned certifies that he/she has read, understands, and agrees to be bound by the bid specifications, including the accompanying Exhibits and other terms and conditions of the Invitation to Bid and/or Request for Proposal regarding LSBE utilization. The undersigned further certifies that he/she is legally authorized by the bidder or responder to make the statements and representations in Exhibit 1 and that said statements and representations are true and correct to the best of his/her knowledge and belief. The undersigned will enter into formal agreement(s) with the LSBE(s) listed in this Exhibit 1, which are deemed by the owner to be legitimate and responsible LSBEs. Said agreement(s) shall be for the work and contract with the Prime Contractor. The undersigned understands and agrees that if any of the statements and representations are made by the Bidder knowing them to be false, or if there is a failure of the successful Bidder (i.e., Contractor) to implement any of the stated agreements, intentions, objectives, goals and commitments set forth herein without prior approval of the County, then in any such events the contractor's act or failure to act, as the case may be, shall constitute a material breach of contract, entitling the County to terminate the Contract for default. The right to so terminate shall be in addition to, and not in lieu of, any other rights and remedies the County may have for other defaults under the Contract. Additionally, the Contractor will be subject to the loss of any future contract awards by the County for a period of one year.

Firm Name (Please Print):

Firm's Officer:

(Authorized Signature and Title Required)	Date
---	------

Sworn to and Subscribed to before me this ____ day of _____, 20__.

Notary Public

My Commission Expires: _____

EXHIBIT 2

**LETTER OF INTENT TO PERFORM AS A SUBCONTRACTOR
 PROVIDING MATERIALS OR SERVICES**

Instructions:

1. Complete the form in its entirety and submit with bid documents.
2. Attach a copy of the LSBE's current valid Certification Letter.

To: _____
 (Name of Prime Contractor Firm)

From: _____ **LSBE –DeKalb** **LSBE –MSA**
 (Name of Subcontractor Firm) (Check all that apply)

ITB Number: 20-101212

Project Name: Scott Candler Water Treatment Plant – Ozone Generators Design and Installation

The undersigned subcontractor is prepared to perform the following described work or provide materials or services in connection with the above project (specify in detail particular work items, materials, or services to be performed or provided).

Description of Materials or Services	Project/Task Assignment	% of Contract Award

Prime Contractor:

Sub-contractor:

Signature: _____ Signature: _____

Title: _____ Title: _____

Date: _____ Date: _____



**DEKALB FIRST
LOCAL SMALL BUSINESS ENTERPRISE PROGRAM**

MENTOR- PROTÉGÉ INITIATIVE

The Mentor Protégé Relationship is required for all projects valued at over \$5,000,000.00. During the term of the contract, the Mentor and Protégé businesses must each provide to the DeKalb First – LSBE Program, a quarterly summary of the mentor skills & training provided to the Protégé, which shall include:

	<u>Place Initials Below</u>	
	<u>Mentor</u>	<u>Protégé</u>
1. List the type of collaboration and training to be provided to the protégé to assist in the growth and development of their business. The areas of assistance that are encouraged include, but are not limited to, bonding and insurance support, management and scheduling support.	_____	_____
2. Names and titles of the individuals from the Mentor who are responsible for working directly with the Protégé in the areas identified above.	_____	_____
3. The amount of time, nature and extent of managerial, technical, financial and bonding assistance provided.	_____	_____
4. A summary and explanation of any projects bid on or undertaken by the Mentor-Protégé partnership in the private sector or for a governmental entity other than DeKalb County.	_____	_____
5. Mentor- Protégé teams must submit fully executed written agreements to the DeKalb First – LSBE Program, which clearly delineates the rights and responsibilities of the Mentor and Protégé, comply with any requirements of the DeKalb First LSBE Program as set forth in the eligible project bid documents, and provide that the Mentor- Protégé relationship shall continue for, at a minimum, the duration of the project. Protégé(s) shall agree not to subcontract any of their work to other contractors without the written approval of the Director.	_____	_____
6. Any additional or further information required by the DeKalb First LSBE Program as set forth in bid documents or otherwise.	_____	_____

(Please initial each line to acknowledge Mentor-Protégé requirements)

Mentor

Protégé

Signature: _____

Signature: _____

Printed Name: _____

Printed Name: _____

Title: _____

Title: _____

Date: _____

Date: _____



ATTACHMENT E

FIRST SOURCE JOBS ORDINANCE INFORMATION
(WITH EXHIBITS 1 – 4)

EXHIBIT 1
FIRST SOURCE JOBS ORDINANCE ACKNOWLEDGEMENT

The DeKalb County First Source Ordinance requires contractors or beneficiaries of eligible projects entering into any type of agreement with the County, including purchase orders, regardless of what they may be called, for the procurement or disposal of supplies, services, construction projects, professional or consultant services, which is funded in whole or part with County funds or County administered funds in which the contractor is to receive \$50,000 or more in County expenditures or committed expenditures and recipient of urban redevelopment action grants or community development block funds administered in the amount of \$50,000 or more to make a good faith effort to hire DeKalb County residents for at least 50% of jobs created using the First Source Registry (candidate database) within one hundred twenty (120) days of contract execution. The work to be performed under this contract is subject to the provisions of the DeKalb County First Source Jobs Ordinance. All contractors will be asked to submit an Employment Roster and/or copies of active payroll registers on a monthly basis to verify compliance. The undersigned acknowledges and agrees to comply with the provisions of the DeKalb County First Source Jobs Ordinance.

CONTRACTOR OR BENEFICIARY INFORMATION:

Contractor or Beneficiary Name (Signature)

Contractor or Beneficiary Name (Printed)

Title: _____

Telephone: _____

Email: _____

Name of Business: _____

Please answer the following questions:

1. How many job openings do you anticipate filling related to this contract? _____
2. How many incumbents/existing employees will retain jobs due to this contract?
DeKalb Residents: _____ Non-DeKalb Residents: _____
3. How many work hours per week constitutes Full Time employment? _____

**Please return this form to WorkSource DeKalb, (404)687-3900 or email to
fkins@dekalbcountyga.gov, malee@dekalbcountyga.gov, vlnicksion@dekalbcountyga.gov,
or jmjones@dekalbcountyga.gov**

WorkSource DeKalb (WSD) is an EEO/M/F/D/V employer/program. Auxiliary aids/services are available upon request to individuals with disabilities. Persons with hearing impairments may call 1-800-255-0135 or 711 TTY for assistance. WSD is 100% funded by the U. S. Department of Labor and is a proud partner of the American Job Center Network. Revised March 2018

FIRST SOURCE JOBS ORDINANCE INFORMATION
EXHIBIT 2

NEW EMPLOYEE TRACKING FORM

Name of Bidder _____
Address _____
E-Mail _____
Phone Number _____
Fax Number _____

Do you anticipate hiring from the First Source Candidate Registry? Y or N (Circle one)

If so, the approximate number of employees you anticipate hiring: _____

Type of Position (s) you anticipate hiring: (List position title, one position per line) Attach job description per job title:	The number you anticipate hiring:	Timeline

Please return this form to Work Source DeKalb, fax (404) 687-4099 or email to FirstSourceJobs@dekalbcountyga.gov.

FIRST SOURCE JOBS ORDINANCE INFORMATION
EXHIBIT 3

BUSINESS SERVICE REQUEST FORM

Please note: We need one form completed for each position that you have available.

DATE: _____ **FEDERAL TAX ID:** _____

COMPANY NAME: _____ **WEBSITE:** _____

ADDRESS:

WORKSITE ADDRESS IF DIFFERENT):

CONTACT NAME:

CONTACT PHONE:

CONTACT FAX:

CONTACT E-MAIL ADDRESS:

Are you a private employment agency or staffing agency? YES NO

JOB DESCRIPTION: (PLEASE INCLUDE A COPY OF JOB DESCRIPTION)

POSITION TITLE:

NUMBER OF POSITIONS AVAILABLE: _____ **TARGET START DATE:** _____

WEEKLY WORK HOURS: 20-30 hours 30-40 hours Other

SPECIFIC WORK SCHEDULE:

SALARY RATE (OR RANGE):

PERM TEMP TEMP-TO-PERM SEASONAL

PUBLIC TRANSPORTATION ACCESSIBILITY YES NO

IF SCREENINGS ARE REQUIRED, SELECT ALL THAT APPLY:

CREDIT DRUG MVR BACKGROUND OTHER _____

Please return form to: Business Solutions Unit (First Source)

774 Jordan Lane Bldg. #4

Decatur, Ga. 30033

Phone: (404) 687-3400

FirstSourceJobs@dekalbcountyga.gov

FIRST SOURCE JOBS ORDINANCE INFORMATION
EXHIBIT 4

EMPLOYMENT ROSTER
DeKalb County CIP Program

Contract Number: _____
 Project Name: _____
 Contractor: _____ Date: _____

Name	Position:	Start Date	Hourly Rate of Pay	Hired for this Project? (yes/no)	Anticipated Length of Employment (Months)	% of Time Dedicated to the Project	Full or Part Time? (No. of Hours)	Georgia County of Residency

Return completed form to WorkSoure DeKalb: mtsolomon@deKalbcountyga.gov

ATTACHMENT F

CERTIFICATE OF CORPORATE BIDDER

I, _____ (*insert name of the Corporate Secretary*), certify that I am Secretary of the corporation named as Bidder herein, same being organized and incorporated to do business under the laws of the State of _____; that _____ (*insert name of individual signing the Bid*) who executed this Bid on behalf of the Bidder was, then and there, _____ (*insert title of individuals signing the Bid*) and that said Bid was duly signed by said officer for and on behalf of said corporation, pursuant to the authority of its governing body and within the scope of its corporate powers.

I further certify that the names and addresses of the owners of all outstanding stock of said corporation as of this date are as follows:

This _____ day of _____, 20____.

By: _____ (Corporate Seal)

ATTACHMENT F, CONT'D

CERTIFICATE OF AUTHORITY – JOINT VENTURE
(Separate Certificate to be submitted by each joint venture partner)

I, _____, ⁽¹⁾ certify that:

1. I am the _____ ⁽²⁾ of _____, ⁽³⁾ (hereinafter “Venturer”);
2. Venturer is a partner and participant in the joint venture having submitted the Invitation to Bid or Request for Proposal No. 20-101212 Scott Candler Water Treatment Plant-Ozone Generators Design and Installation for;
3. Venturer is organized and incorporated to do business under the laws of the State of _____; and
4. Said Invitation to Bid or Request for Proposal No. _____ was duly signed by said officer for and on behalf of said Venturer and the Contractor pursuant to the authority of the governing body of each and within the scope of its corporate powers.

I further certify that the names and addresses of the owners of all the outstanding stock or ownership interest in Venturer as of this date are as follows:

This _____ day of _____, 20____.

By: _____
Signature of Person Executing Certification

INSTRUCTIONS FOR COMPLETION OF THIS CERTIFICATE:

1. Name of secretary (if Venturer is a corporation), or Manager or CEO (if Venturer is an LLP) of Venturer.
2. Title of person executing Certification.
3. Name of joint venture partner.

COPY THIS FORM AND SUBMIT SEPARATE CERTIFICATES FOR EACH JOINT VENTURE PARTNER WITH THE BID OR PROPOSAL.

ATTACHMENT G

BIDDER’S AFFIDAVIT OF COMPLIANCE WITH O.C.G.A. §13-10-91

By executing this affidavit, the undersigned verifies its compliance with O.C.G.A. § 13-10-91, as amended, stating affirmatively that the Bidder submitting a Bid to DEKALB COUNTY, GA, a political subdivision of the State of Georgia, has registered with and is participating in a federal work authorization program, commonly known as E-Verify, or any subsequent replacement program, in accordance with the applicable provisions and deadlines established in O.C.G.A. § 13-10-91, as amended. The undersigned further verifies that it will continue to use the federal work authorization program for the Contract Term, and it will only contract with Subcontractors who have registered for the federal work authorization program. The undersigned hereby attests that its federal work authorization user identification number and date of authorization are as follows:

Federal Work Authorization User Identification Number

Date of Authorization

Name of Contractor

ITB 20-101212 Scott Candler Water Treatment Plant – Ozone Generators Design and Installation
Name of Project

DeKalb County, GA Government
Name of Public Employer

I hereby declare under penalty of perjury that the foregoing is true and correct.
Executed on _____, ___, 20__ in _____ (city), _____ (state).

By: _____
Signature of Authorized Officer or Agent

Printed Name and Title of Authorized Officer or Agent

Subscribed and Sworn before me on this the
____ day of _____, 20__.

NOTARY PUBLIC
My Commission Expires:

ATTACHMENT H

SUBCONTRACTOR AFFIDAVIT OF COMPLIANCE WITH O.C.G.A. § 13-10-91

By executing this affidavit, the undersigned Subcontractor verifies its compliance with O.C.G.A. § 13-10-91, stating affirmatively that the individual, firm or corporation which is engaged in the physical performance of services under a contract with _____ (insert name of Contractor) on behalf of DEKALB COUNTY, GEORGIA has registered with, is authorized to use and uses the federal work authorization program commonly known as E-Verify, or any subsequent replacement program, in accordance with the applicable provisions and deadlines established in O.C.G.A. § 13-10-91. Furthermore, the undersigned Subcontractor will continue to use the federal work authorization program throughout the contract period and the undersigned subcontractor will contract for the physical performance of services in satisfaction of such contract only with sub-subcontractors who present an affidavit to the Subcontractor with the information required by O.C.G.A. § 13-10-91. Additionally, the undersigned Subcontractor will forward notice of the receipt of an affidavit from a sub-subcontractor to the Contractor within five business days of receipt. If the undersigned Subcontractor receives notice that a sub-subcontractor has received an affidavit from any other contracted sub-subcontractor, the undersigned Subcontractor must forward, within five business days of receipt, a copy of the notice to the Contractor. Subcontractor hereby attests that its federal work authorization user identification number and date of authorization are as follows:

Federal Work Authorization User Identification Number

Date of Authorization

Name of Subcontractor

ITB 20-101212 Scott Candler Water Treatment Plant – Ozone Generators Design and Installation
Name of Project

DeKalb County, GA Government
Name of Public Employer

I hereby declare under penalty of perjury that the foregoing is true and correct.

Executed on _____, 20__ in _____ (city), _____ (state).

By: _____
Signature of Authorized Officer or Agent

Printed Name and Title of Authorized Officer or Agent

Subscribed and Sworn before me on this the
_____ day of _____, 20__.

NOTARY PUBLIC

My Commission Expires: _____

ATTACHMENT I

CONTRACTOR REFERENCE AND RELEASE FORM

List below at least three (3) references, including company name, contact name, address, email address, telephone numbers and contract period who can verify your experience and ability to design, procure, test, supply equipment and the installation of a minimum of two (2) Ozone Generator systems within the past ten (10) years.

Company Name	Contract Period		
Contact Person Name and Title	Telephone Number (include area code)		
Complete Primary Address	City	State	Zip Code
Email Address	Fax Number (include area code)		
Project Name and Description	Services Provided		

Company Name	Contract Period		
Contact Person Name and Title	Telephone Number (include area code)		
Complete Primary Address	City	State	Zip Code
Email Address	Fax Number (include area code)		
Project Name and Description	Services Provided		

Company Name	Contract Period		
Contact Person Name and Title	Telephone Number (include area code)		
Complete Primary Address	City	State	Zip Code
Email Address	Fax Number (include area code)		
Project Name and Description	Services Provided		

REFERENCE CHECK RELEASE STATEMENT

You are authorized to contact the references provided above for purposes of this ITB.

Signed _____ Title _____
 (Authorized Signature of Bidder)

Company Name _____ Date _____

ATTACHMENT J

SUBCONTRACTOR REFERENCE AND RELEASE FORM

List below at least three (3) references, including company name, contact name, address, email address, telephone numbers and contract period who can verify your experience and ability to perform the type(s) of services(s) listed in this solicitation.

Company Name	Contract Period		
Contact Person Name and Title	Telephone Number (include area code)		
Complete Primary Address	City	State	Zip Code
Email Address	Fax Number (include area code)		
Project Name and Description	Services Provided		

Company Name	Contract Period		
Contact Person Name and Title	Telephone Number (include area code)		
Complete Primary Address	City	State	Zip Code
Email Address	Fax Number (include area code)		
Project Name and Description	Services Provided		

Company Name	Contract Period		
Contact Person Name and Title	Telephone Number (include area code)		
Complete Primary Address	City	State	Zip Code
Email Address	Fax Number (include area code)		
Project Name and Description	Services Provided		

REFERENCE CHECK RELEASE STATEMENT

You are authorized to contact the references provided above for purposes of this ITB.

Signed _____ Title _____
 (Authorized Signature of Bidder)

Company Name _____ Date _____

STATE OF GEORGIA
COUNTY OF DEKALB

ATTACHMENT K

**CONTRACTOR AFFIDAVIT AND
OATH OF SUCCESSFUL BIDDER**

Personally, appeared before me, the undersigned officer, duly authorized to administer oaths,
_____, (*insert name*), who, after being duly sworn, deposes as follows:

I, _____, (*insert name*), am a competent adult, and I have personal knowledge of the facts set forth in this Affidavit and Oath which I make for any lawful use or purpose.

I, _____ (*insert name*) swear or affirm that I have not prevented or attempted to prevent competition in bidding or submitting a proposal for this Project by any means whatsoever. I swear or affirm that I have not prevented or endeavored to prevent anyone from making a Bid for this Project by any means whatsoever, I swear I have not caused or induced any other person to withdraw a Bid for this Project. I swear or affirm that I have not violated O.C.G.A. §36-91-21(d) in any way, directly or indirectly.

I hereby declare under penalty of perjury that the foregoing is true and correct. Executed on
_____, 20__ in _____ (*city*), _____ (*state*).

By: _____
Signature

Print Name of Affiant

Print Title of Affiant

Subscribed and Sworn before me on this the
_____ day of _____, 20_____.

NOTARY PUBLIC
My Commission Expires:

ATTACHMENT L
REQUIRED DOCUMENTS CHECKLIST

Bidder shall complete and submit the following documents with their bid:

Bid Page No.	Title	Check This Box If Included with Bid
3	Acknowledgement of Bidder*	
26-28	Bidder's Unit Price Form (1 Copy, Separate & Sealed) *	
29-32	Bidder's Bond Acknowledgement and Bid Bond Form*	
33-42	DeKalb First LSBE Information with Exhibits 1-2 & Mentor-Protégé Initiative Form*	
43-46	First Source Jobs Ordinance Information with Exhibits 1 – 4*	
47-48	Certificate of Corporate Bidder / Certificate of Authority – Joint Venture Bidder *	
49	Bidder's Affidavit of Compliance with Under O.C.G.A. 13-10-91*	
50	Subcontractor Affidavit of Compliance With O.C.G.A. 13-10-91**	
51	Contractor Reference and Release Form*	
52	Subcontractor Reference and Release Form, if applicable**	
53	Contractor Affidavit and Oath of Successful Bidder*	
54	Required Documents Checklist *	
-----	Initial Design Information & Drawing and Data *See Exhibit 4 Technical Criteria – Ozone Generators Required Bidder Submittal Information 2.4.19*	

***If these mandatory forms are not completed and submitted with the bid, the bidder will be deemed non-responsive.**

****These forms are applicable if a subcontractor will be utilized to fulfill the requirements of this contract. If these forms are applicable, they must be completed and submitted with the bid. Failure to submit these forms, if applicable, will result in the bidder's bid being deemed non-responsive.**

I, the undersigned, acknowledge that I have included the requested documents as listed above.

 Print Name

 Signature

ATTACHMENT M

STANDARD FORM CONTRACT FOR CONSTRUCTION

STATE OF GEORGIA

COUNTY OF DEKALB

SAMPLE

CONTRACT FOR CONSTRUCTION

THIS CONTRACT, made as of this ____ day of _____, 20____, (hereinafter called the “execution date”) by and between, **DEKALB COUNTY**, a political subdivision of the State of Georgia (hereinafter called the “County”) and _____, a _____ organized pursuant to the laws of the State of _____ (hereinafter called the “Contractor”).

I. SCOPE OF WORK

A. The term “Work” means the construction, labor, materials, equipment, tools, machinery, testing, temporary services and utilities, supervision, administration, coordination, planning, insurance, bonds, transportation, security, and all other services and things necessary to provide the County with the facilities, improvements, features, and functions in strict conformity with the General Requirements attached hereto as Attachment A, and as described in the Specifications and the Drawings included in the Bid Document Package. The Contractor agrees to complete the Work in a good, firm, substantial and workmanlike manner in strict conformity with this Contract.

(1) The Work relates to the following Project:

**ITB 20-101212 SCOTT CANDLER WATER TREATMENT PLANT-
OZONE GENERATORS DESIGN AND INSTALLATION**

B. Unless otherwise stipulated, the Contractor shall furnish all of the Work in accordance with the Contract and all incidental work necessary to complete the Project in an acceptable manner, ready for use, occupancy, or operation by the County. The Contractor shall be responsible for the entire Work and every part thereof.

II. TIME, TERM AND LIQUIDATED DAMAGES

A. **Contract Time.** The Contractor shall commence the Work under this Contract within ten (10) days from the date on the Notice to Proceed. Contractor shall fully complete the Work within (577) calendar days from and including the date on the Notice to Proceed. If the Change Order only seeks to extend the Contract Time, it may be approved and executed by the DeKalb County Chief Executive Officer or his/her designee and the Contractor in accordance with the terms of this Contract.

- B. Contract Term.** As allowed by O.C.G.A. §36-60-15.1, this Contract shall commence immediately upon the execution date. This Contract shall terminate without further obligation on the part of the County, with no further renewals, on **December 31, 2022**, unless extended by Change Order adopted and approved by the DeKalb County Governing Authority and the Contractor in accordance with the terms of this Contract.
- C. Liquidated Damages.** The Contractor acknowledges that time is of the essence with respect to the Work governed by this Contract. Contractor acknowledges and recognizes that if it fails to achieve Substantial Completion of any portion of the Work within the Contract Time as may be extended in accordance with the terms of this Contract, the County will sustain substantial losses as a result of such failure. The Contractor further acknowledges that the County will suffer damages that are difficult if not impossible to accurately estimate. Contractor shall pay liquidated damages of One Thousand Dollars (\$1,000.00) for each day that Substantial Completion and One Thousand Five Hundred Dollars (\$1,500.00) per day for each day that Final Completion of the Work is delayed past the Contract Time. The Contractor agrees that the foregoing rate is a reasonable pre-estimate of the probable damages that the County will suffer if Substantial Completion is delayed, and said daily rate is intended to compensate the County for its damages and is not intended to penalize the Contractor for its delay. The County may deduct such liquidated damages from any unpaid amounts then or thereafter due the Contractor under this Contract. Any liquidated damages not deducted from any unpaid amounts due the Contractor are payable to the County at the County's demand, together with interest from the date of the demand at a rate equal to seven percent (7%) per annum.

Should the Generator Acceptance Tests indicate that the generator performance falls outside of the requirements of the test standard, liquidated damages as deemed by the Owner shall be applied at One Thousand Dollars (\$1,000.00) each day.

No disruption of the existing operations will exceed more than 3 (three) hours on any day. This time will not include isolation and purging of headers/tie in points, which will be done in liaison with the operational staff at the Plant. The Contractor shall pay the County liquidated damages in the amount of One Thousand Dollars (\$1,000.00) per hour or any portion thereof for any period longer than 3 (three) hours.

III. PAYMENT

- A. Contract Price.** As full payment for the faithful performance of this Contract, the County shall pay the Contractor, the Contract Price, which is an amount not to exceed XXXXXX (\$XXXXXXXX), unless changed by written Change Order in accordance with the terms of this Contract. The term "Change Order" includes the term "amendment" and shall mean a written order authorizing a change in the Work, and an adjustment in Contract Price to Contractor or the Contract Term, as adopted and approved by the Contractor and the DeKalb County Governing Authority, or the Chief Executive Officer, if exempted from Governing Authority adoption and approval in accordance with the express terms of this Contract. The Chief Executive Officer or his/her designee shall have the authority to approve and execute a Change Order lowering the Contract Price or increasing the Contract Price up to twenty percent (20%) of the original Contract Price, provided that the total amount of the increase authorized

by such Change Order is less than \$100,000.00. If the original Contract or Purchase Order Price does not exceed \$100,000.00, but the Change Order will make the total Contract Price exceed \$100,000.00, then the Change Order will require approval by official action of the Governing Authority. Any other increase of the Contract Price shall be by Change Order adopted and approved by the DeKalb County Governing Authority and the Contractor in accordance with the terms of this Contract. Amounts paid to the Contractor shall comply with and not exceed Attachment B, the Contractor's Cost Proposal, consisting of (4) page(s) attached hereto and incorporated herein by reference. Payment is to be made no later than thirty (30) days after submittal of undisputed invoice.

B. Retainage and Partial Payments. Partial payments to the Contractor shall be made monthly, based on the value of Work completed as determined by the County, plus the value of materials and equipment suitably stored, insured and protected at the construction site. The Contractor shall submit a payment request for Work completed during the preceding calendar month to Dora De Taboada (Project Manager) for review and approval on or before last day of each month. If approved by the Project Manager or Designated Representative, the approved amount, less retainage, shall be paid to the Contractor thirty (30) days after the date the approved payment request is received by the County Finance Department. If a payment request is not approved by the County, then no payment shall be made to the Contractor until after the Project Manager or Designated Representative approves the payment request. The amount of retainage shall be as follows:

- (1) Ten percent (10%) of each partial payment shall be withheld as retainage until the value of fifty percent (50%) of the Contract Price, including Change Orders and other authorized additions provided in the Contract, is due;
- (2) When fifty percent (50%) of the Contract Price, as described above, becomes due and the manner of completion of the Work and its progress, quality, schedule are reasonably satisfactory to the County, and there are no outstanding claims by the Contractor, Subcontractors, lower tier subcontractors, as that term is defined by state law, or Suppliers, the withholding of retainage shall be discontinued.
- (3) If after discontinuing retainage, the County determines that the Work is unsatisfactory or has fallen behind schedule, withholding of ten percent (10%) of each request for payment may be resumed. When the Work has reached Substantial Completion and the County determines the Work to be reasonably acceptable, the Contractor shall submit an invoice or other documents as may be required and receive payment of retainage within thirty (30) days. If minor items remain incomplete at that time, an amount equal to two hundred percent (200%) of the value of each item, as determined by the County, shall be withheld until such items are completed.
- (4) The Contractor shall within ten days from the Contractor's receipt of each payment from the County pass through payments to Subcontractors and shall reduce each Subcontractor's retainage in the same manner as the Contractor's retainage is reduced by the County. The Subcontractor shall, within ten days from the Subcontractor's receipt of payment, pass through payments to lower tier

subcontractors and shall reduce each lower tier subcontractor's retainage in the same manner as the Subcontractor's retainage is reduced.

- (5) Contractor and County agree to abide by all applicable provisions of Georgia state law concerning retainage, including but not limited to O.C.G.A. § 13-10-80 and 13-10-81. If the terms of this contract concerning retainage conflict with state law, state law governs.
- (6) As required by O.C.G.A. § 13-10-81, Retainage shall be invested by the County at the current market rate and any interest earned on the retained amount shall be paid to the Contractor when the Project has been completed within the time limits specified and for the price specified in this Contract or in change orders approved in accordance with the terms of this Contract, upon the County's receipt of certification by the engineer in charge of the Project in the manner and form required by O.C.G.A. §13-10-81.

C. **Payment Requests and Invoices.** Payment Requests and invoice(s) must be submitted as follows:

- (1) Original(s) must be submitted to:

Attn: Dora De Taboada (Project Manager)
Department of Watershed Management
4575 Memorial Drive, Decatur, GA 30032

- (2) Upon award, Prime Contractor(s) with Local Small Business Enterprise (LSBE) Subcontractor(s) shall enter utilization reports electronically at www.dekalblsbe.info. Proof of payment to the LSBE Subcontractor must be uploaded and submitted. LSBE Subcontractors shall confirm receipt of payment from the Prime, electronically also, at www.dekalblsbe.info.

D. **Title.** All equipment, materials, and Work covered by partial payments shall, upon payment thereof, become the sole property of the County, but this provision shall not be construed as relieving the Contractor from the sole responsibility for the care and protection of equipment, materials, and Work upon which payments have been made, or the restoration of any damaged Work.

E. **Final Payment.** Within sixty (60) days after the Work is fully completed and accepted by the County, the balance due hereunder shall be paid; provided, however, that final payment shall not be made until said Contractor shall have completed all Work necessary and reasonably incidental to the Contract, including final cleanup and restoration. Acceptance of the Work and the making of final payment shall not constitute a waiver of any claims by the County. All claims by the Contractor for breach of contract, violation of state or federal law, or compensation and extensions of time shall be submitted in writing to the Chief Executive Officer within sixty (60) days after completion and acceptance of the Work as herein provided, or all such claims shall be forever barred.

V. NOTICE

Any notice or consent required to be given by or on behalf of any party hereto to any other party hereto shall be in writing and shall be sent to the County's Chief Executive Officer and the Executive Assistant or to the Contractor or his authorized representative on the work site by (a) registered or certified United States mail, return receipt requested, postage prepaid, (b) personal delivery, or (c) overnight courier service. All notices sent to the addresses listed below shall be binding unless said address is changed in writing no less than fourteen days before such notice is sent. Future changes in address shall be effective upon written notice being given by the Contractor to the County's Executive Assistant or by the County to the Contractor's authorized representative via certified first-class U.S. mail, return receipt requested. Such notices will be addressed as follows:

If to the County:

Chief Executive Officer
The Maloof Center
1300 Commerce Drive, 6th Floor
Decatur, Georgia 30030

and

Executive Assistant
The Maloof Center
1300 Commerce Drive, 6th Floor
Decatur, Georgia 30030

With a copy to: Director of the Department of Purchasing and Contracting
The Maloof Center
1300 Commerce Drive, 2nd Floor
Decatur, Georgia 30030

With a copy to: _____

If to the Contractor:

With a copy to: *(Insert Contractor name and address)*

V. FEDERAL WORK AUTHORIZATION

- A. Pursuant to O.C.G.A. §13-10-91, the County cannot enter into a contract for the physical performance of services unless the Contractor, its Subcontractor(s) and sub-subcontractor(s), as that term is defined by state law, register and participate in the Federal Work Authorization Program to verify specific information on all new employees.
- B. Contractor certifies that it has complied and will continue to comply throughout the Contract Term with O.C.G.A. §13-10-91 and any related and applicable Georgia Department of Labor Rule.
- C. Contractor agrees to sign an affidavit evidencing its compliance with O.C.G.A. §13-10-91. The signed affidavit is attached to this Contract as Attachment C.
- D. Contractor agrees that in the event it employs or contracts with any Subcontractor(s) in connection with this Contract, Contractor will secure from each Subcontractor an affidavit that certifies the Subcontractor's current and continuing compliance with O.C.G.A. §13-10-91 throughout the Contract Term. Any signed Subcontractor affidavit(s) obtained in connection with this Contract shall be attached hereto as Attachment D
- E. Each Subcontractor agrees that in the event it employs or contracts with any sub-subcontractor(s), each Subcontractor will secure from each sub-subcontractor an affidavit that certifies the sub-subcontractor's current and continuing compliance with O.C.G.A. §13-10-91 throughout the Contract Term. Any signed sub-subcontractor affidavit(s) obtained in connection with this Contract shall be attached hereto as Attachment E.

VI. CORPORATE AUTHORITY

Contractor agrees to execute the Certificate of Corporate Authority, attached hereto as Attachment F. The officials of the Contractor executing this Contract are duly and properly in office and are fully authorized and empowered to execute the same for and on behalf of the Contractor. Contractor warrants that it has all requisite power and authority to enter into and perform its obligations under this Contract, and that the execution and delivery by the Contractor of this Contract and the compliance by the Contractor with all of the provisions of this Contract (i) is within the purposes, powers, and authority of the Contractor; (ii) has been done in full compliance with applicable law and has been approved by the governing body of the Contractor and is legal and will not conflict with or constitute on the part of the Contractor a violation of or a breach of or a default under any indenture, mortgage, security deed, pledge, note, lease, loan, or installment sale agreement, contract, or other agreement or instrument to which the Contractor is a party or by which the Contractor is otherwise subject or bound, or any license, judgment, decree, law, statute, order, writ, injunction, demand, rule, or regulation of any court or governmental agency or body having jurisdiction over the Contractor; and (iii) has been duly authorized by all necessary action on the part of the Contractor. This Contract is the valid, legal, binding and enforceable obligation of the Contractor.

VII. PERFORMANCE AND PAYMENT BONDS AND INSURANCE REQUIREMENTS

- A. Within ten (10) days from the date of Notice of Award of this Contract, the Contractor, as principal, shall give a Contract performance bond, attached hereto as Attachment G and a payment bond, attached hereto as Attachment H, each in the amount of \$XXXXXXXXXX, for the use of all persons doing work or furnishing skills, tools, machinery, or materials under or for the purpose of this Contract, in accordance with the applicable provisions of Georgia state law, including but not limited to, O.C.G.A. §13-10-1 and §36-91-21 *et seq.* The bonds shall be underwritten by a surety company licensed to write bonds in the State of Georgia, listed in the most current U.S. Treasury Circular No. 570, and which have a current A.M. Best rating of "A" (Excellent) with a Financial Size Category of XII or better. The life of these bonds shall extend throughout the Contract Term including a sixty (60) day maintenance period (where applicable) and a twelve-month guarantee period after the completion of Work performed under this Contract. The bonds shall issue on the forms provided by the County as part of this Contract.
- B. It is further agreed between the parties hereto that if at any time after the execution of this Contract and the surety bonds, the County shall deem the surety or sureties upon such bonds to be unsatisfactory, or if, for any reason, such bonds cease to be adequate to cover the performance of the Work, the Contractor shall, at its sole expense and within five (5) days after the receipt of notice from the County to do so, furnish additional bond or bonds in such form and amount and with such surety or sureties as shall be satisfactory to the County.
- C. The Contractor shall, without expense to the County, provide certificates of insurance, and copies of signed insurance policies including declarations pages from companies that are authorized to engage in the insurance business in the state of Georgia and are otherwise acceptable to the County Finance Director or his/her designee, attached hereto as Attachment I. Such insurance shall be placed with admitted insurers that maintain an A.M. Best's rating of not less than A (Excellent) with a Financial Size Category of VII or better with coverage forms acceptable to Contractor. The insurance described below shall be maintained uninterrupted for the duration of the project, including any warranty periods, and shall protect Contractor, and others as required by contract, for liabilities in connection with work performed by or on behalf of Contractor, its agents, representatives, employees or Contractors.
- (1) *Workers Compensation Insurance.* Statutory workers compensation insurance is to be provided in compliance with the requirements of Georgia law with limits not less than the following:
- | | |
|---|-------------|
| Employer's liability insurance by accident, each accident | \$1,000,000 |
| Employer's liability insurance by disease, policy limit | \$1,000,000 |
| Employer's liability insurance by disease, each employee | \$1,000,000 |
- (3) *Commercial General Liability Insurance.* Commercial general liability insurance is to be provided with limits not less than the following:
- \$1,000,000 per occurrence for bodily injury and property damage liability

- \$1,000,000 personal and advertising injury liability
- \$2,000,000 general aggregate
- \$2,000,000 products-completed operations aggregate
- \$ 100,000 damage to rented premises (each occurrence)
- \$ 5,000 medical expense (any one person)

(3) *Umbrella or Excess Insurance.* Umbrella or excess insurance is to be provided with General Liability, Auto Liability and Employers Liability scheduled as underlying policies with limits not less than the following:

- \$5,000,000 per occurrence
- \$5,000,000 aggregate

(4) *Comprehensive Automobile Liability Insurance.* Comprehensive automobile liability insurance with form coverage is to be provided for all owned, non-owned and hired vehicles with combined single limit of \$1,000,000. Automobile liability insurance shall be written on ISO Business Auto Coverage Form CA 0001 (1990 edition or later), or a substitute form providing equivalent coverage, and shall cover liability for bodily injury and property damage arising from the use or operation of any automobile, including those owned, hired or otherwise operated or used by or on behalf of Contractor. The policy must include Broadened Pollution Liability Endorsement CA9948 12 93.

(5) *Builder’s Risk Insurance Coverage.* DeKalb County shall procure and maintain Builders Risk Insurance on the entire work which provides “All-risk” form that shall at least include insurance for physical loss or damage to the Work, temporary buildings, falsework, and materials and equipment in transit, and shall insure against at least the following perils or causes of loss: fire, lightning, extended coverage, theft, vandalism, malicious mischief, earthquake, collapse, debris removal, demolition occasioned by enforcement of Laws and Regulations, water damage (other than caused by flood), and such other perils or causes of loss as may be specifically required by Supplementary Conditions) until Final Completion and Acceptance of the Project. Such policy of insurance shall contain at least the following sub-limits of insurance and deductibles:

Sub-limits:	
Property in Transit	\$1,000,000
Property in Offsite Storage	\$1,000,000
Plans & Blueprints	\$25,000
Debris Removal	25% of Insured Physical Loss
Delay in Completion / Soft Cost	TBD
Ordinance of Law (Increased Cost of Construction)	\$1,000,000
Flood and Earthquake	TBD – Full Contract Value
Deductibles:	
Flood and Earthquake	\$25,000

Water Damage other than Flood	\$100,000
All other Perils	\$10,000

- D. The County, its elected officials, officers, employees and agents, hereinafter referred to in this article and in the article entitled “Certificates of Insurance” as “the County and its officers” are to be named as additional insured on all policies of insurance except worker’s compensation insurance with no cross suits exclusion. The County and its officers shall be included as additional insureds under commercial general liability and commercial umbrella insurance, for liabilities arising out of both the ongoing and completed operations of Contractor. Such additional insured coverage shall be endorsed to Contractor’s policy by attachment of ISO Additional Insured Endorsement forms CG 20 10 10 01 (ongoing operations) and CG 20 37 10 01 (products-completed operations), or form(s) providing equivalent coverage.
- E. All coverages required of the Contractor will be primary over any insurance or self-insurance program carried by the County.
- F. If the Contractor is a joint venture involving two (2) or more entities, then each independent entity will satisfy the limits and coverages specified here or the joint venture will be a named insured under each respective policy specified.
- G. In addition to procuring and maintaining commercial general liability insurance, automobile liability and commercial umbrella insurance, for the Contract Term, Contractor shall continue to procure and maintain the products-completed operations liability insurance coverage and commercial umbrella insurance after the Work is substantially complete for the entire Contract Term or for the applicable five-year statutory limitation, whichever is greater. For such period of time, all terms and conditions of such coverage shall remain unchanged, including the limits specified herein and the requirement to provide the County with coverage as an additional insured.
- H. Contractor agrees to waive all rights of subrogation and other rights of recovery against the County and its officers and shall cause each Subcontractor to waive all rights of subrogation for all coverage.
- I. Failure of the County to demand such certificate or other evidence of full compliance with these insurance requirements or failure of the County to identify a deficiency from evidence provided will not be construed as a waiver of the Contractor’s obligation to maintain such coverage.
- J. Contractor understands and agrees that the purchase of insurance in no way limits the liability of the Contractor.
- K. CIP Insurance Coverage: In connection with the Work, and for the Contractor and those subcontractors deemed eligible by the County for participation, the County will implement an Owner Controlled Insurance Program (“OCIP”), providing certain insurance coverages as detailed herein. The insurance coverages provided by the OCIP apply only to the Work performed on the Project site. The Contractor and its Subcontractors shall provide their

own insurance for all off-site activities. The Builder's Risk/All Risk Property Insurance component of the OCIP will expressly exclude coverage on Contractor's and Subcontractors' machinery, tools, and equipment not destined to become a part of the Project Work.

(1) Exclusion of Contractor Insurance Costs

Because the County is providing specific limits of General Liability, Excess Liability and Property Coverage (for eligible workers), following enrollment in the OCIP the Contractor shall exclude all General Liability, Excess Liability, and Property Coverage (Builder's Risk) costs from the Contract Price and its bid for itself and for all included Subcontractors. The Contractor warrants, for itself and all included Subcontractors, that all such on-site insurance costs for the coverages listed above shall be excluded in their entirety from the Contract Price, and no such coverage is duplicated by the Contractor or any Subcontractor of any tier. The Contractor and its Subcontractors shall make available to the County all documentation deemed necessary by the County in order to verify this cost exclusion. If requested by the County, the Contractor shall provide complete copies of its and its Subcontractors' current insurance policies in order to assist in the verification of the accuracy of the exclusion of insurance costs and to verify the accuracy of the information provided by the Contractor and its Subcontractors.

- L. OCIP Manual of Insurance Procedures: The OCIP coverage provided by the County shall be further detailed in, and the Contractors requirements with respect to the OCIP shall be described in, the General Liability Wrap-Up Manual ("the Manual") incorporated into the Contract Documents and issued via an Exhibit to the Contract. This Manual includes information on the following OCIP coverages: Commercial General Liability, Excess Liability, and Builder's Risk/All Risk Property Insurance.

VIII. CERTIFICATES OF INSURANCE

- A. Certificates shall state that the policy or policies shall not expire, be cancelled or altered without at least sixty (60) days prior written notice to the County. Policies and Certificates of Insurance listing the County and its officers as additional insureds (except for workers' compensation insurance) shall conform to all terms and conditions (including coverage of the indemnification and hold harmless agreement) contained in this Contract.
- B. The Contractor agrees to name the County and its officers as additional insured on the commercial general liability insurance, using the ISO Additional Insured Endorsement forms CG20101001 (ongoing operations) and CG20371001 (products-completed operations) forms, or form(s) providing equivalent coverage.
- C. Certificates of Insurance must contain the policy number, policy limits, and policy expiration date of all policies issued in accordance with this Contract; the location and operations to which the insurance applies. Certificates must be provided annually for the duration of the project. If applicable, a specific statement must be included that blasting

coverage is included to the extent such risk is present; that Contractor's protective coverage applies to any Subcontractor's operations; and Contractor's contractual liability insurance coverage applies to any Subcontractor.

- D. This insurance for the County as the additional insured shall be as broad as the coverage provided for the named-insured Contractor. It shall apply as primary insurance before any other insurance or self-insurance, including any deductible, non-contributory, and waiver of subrogation provided to the County as the additional insured.
- E. The Contractor shall be wholly responsible for securing certificates of insurance coverage as set forth above from all Subcontractors who are engaged in the Work.
- F. If the County shall so request, the Contractor will furnish the County for its inspection and approval such policies of insurance with all endorsements, or confirmed specimens thereof certified by the insurance company to be true and correct copies.
- G. Contractor shall be responsible and have the financial wherewithal to cover any deductibles or retentions included on the certificate of insurance.
- H. Such certificates should be sent to the County and must identify the "Certificate Holder" as follows:

DeKalb County, Georgia
Director of Purchasing & Contracting
The Maloof Center
1300 Commerce Drive, 2nd Floor
Decatur, Georgia 30030

- I. Copies of Required Insurance policies with Declarations Page(s) shall be attached hereto as Attachment H.

IX. ATTACHMENTS

- A. This Contract includes the following Attachments all of which are incorporated herein by reference:

Attachment A, General Requirements, GR-1 through GR-46.

Attachment B, Bidder's Unit Price Form

Attachment C, Contractors Affidavit Under O.C.G.A. § 13-10-91

Attachment D, Subcontractor Affidavit Under O.C.G.A. § 13-10-91

Attachment E, Sub-Subcontractor Affidavit Under O.C.G.A. § 13-10-91

Attachment F, Certificate of Corporate Authority or Joint Venture Certificates

Attachment G, Performance Bond and Accompanying Power of Attorney

Attachment H, Payment Bond and Accompanying Power of Attorney

Attachment I, Copies of Required Insurance policies with Declarations Page(s)

Attachment J, Executive Order No. 2141-4 New Ethics Policy

Attachment K, OCIP General Liability Wrap-Up Manual

Attachment L, License (s) and/or Certifications

- B. In addition to the foregoing, the Bid Document Package dated January 21, 2020 the original of which is maintained in the County's Department of Purchasing and Contracting, forms an essential part of this Contract as if fully set out herein.

[SIGNATURES APPEAR ON NEXT PAGE]

IN WITNESS WHEREOF, the parties hereto have set their hands and caused their seals to be affixed hereupon in four (4) counterparts, each to be considered as an original by their authorized representatives.

NAME OF CONTRACTOR

DEKALB COUNTY, GEORGIA

By: _____
Signature (SEAL)

_____ **by Dir.** (SEAL)
MICHAEL L. THURMOND
Chief Executive Officer
DeKalb County, Georgia

Name (Typed or Printed)

Date

Title

Federal Tax I.D. Number

Date

ATTEST:

ATTEST:

Signature

BARBARA H. SANDERS, CCC, CMC
Clerk of the Chief Executive Officer
and Board of Commissioners of
DeKalb County, Georgia

Name (Typed or Printed)

Title

APPROVED AS TO SUBSTANCE:

APPROVED AS TO FORM:

Reginald D. Wells, Director
Department of Watershed Management

County Attorney Signature

County Attorney Name
(Typed or Printed)

ATTACHMENT A

GENERAL REQUIREMENTS

INDEX TO GENERAL REQUIREMENTS

<u>Section</u>	<u>Title</u>
GR-1	Definitions of Terms
GR-2	Prior Use by County.....
GR-3	Contractor’s Obligations
GR-4	Authority of the County
GR-5	Changes in the Work and Change Orders
GR-6	Time for Completion.....
GR-7	Schedules, Reports, and Records
GR-8	County’s Right to Suspend or Terminate Work
GR-9	Final Inspection
GR-10	Warranties, Guarantees and Correction of Work.....
GR-11	Contractor’s Personnel and Independent Contractor Status
GR-12	Subcontracting
GR-13	Assignments
GR-14	Indemnification and Hold Harmless
GR-15	Royalties and Patents
GR-16	Laws and Regulations
GR-17	Permits and Inspection Fees.....
GR-18	Land and Rights-of-Way.....
GR-19	Protection of Work, Property, and Persons.....
GR-20	Prohibited Interests
GR-21	First Source Jobs Ordinance
GR-22	Foreign Corporations
GR-23	Specification and Drawings
GR-24	Contractor’s Submittals
GR-25	As-Built Drawings
GR-26	Examination of Work by Contractor.....
GR-27	Inspection and Testing of Materials.....
GR-28	Inspection of Work
GR-29	Requests for Substitutions.....
GR-30	Rejections of Work and Materials
GR-31	Materials, Services, and Facilities
GR-32	Utilities During Construction.....
GR-33	Temporary Heat and Air Conditioning
GR-34	Maintenance Manual.....
GR-35	Weather Conditions
GR-36	Lines, Grades, and Measurements
GR-37	Cleaning Up

GR-38	Barricades
GR-39	No Third-Party Beneficiary.....
GR-40	Severability
GR-41	Interpretation.....
GR-42	Prior Contracts; Conflict in Documents.....
GR-43	Entire Agreement.....
GR-44	Counterparts
GR-45	Venue
GR-46	Right to Audit.....

GR-1. DEFINITIONS OF TERMS

The section captions contained in this Contract are for convenience only and do not in any way limit or amplify any term or provision hereof. The use of the terms "hereof," "hereunder" and "herein" shall refer to this Contract as a whole, inclusive of the Attachments, except when noted otherwise. The use of the masculine or neuter genders herein shall include the masculine, feminine and neuter genders and the singular form shall include the plural when the context so requires. The following terms shall have the meanings indicated:

“Addendum” or “Addenda” shall mean written or graphic instruments issued prior to the execution of the Contract, which modify or interpret the Work, or the Invitation to Bid by additions, deletions, clarifications, or corrections.

“Bid” shall mean the offer of the Bidder submitted on the prescribed form setting forth the price(s) for the Work to be performed.

“Bid Document Package” shall consist of documents entitled as follows: Acknowledgement of Contractor, Advertisement for Bids, Instructions to Bidders, Addenda, Business License, Utility Systems Contractor’s License, Utility Manager’s Certificate, Utility Foreman’s Certificate, General Contractor’s License, Bidder’s Lump Sum Cost, Bidder’s Unit Price, First Source Jobs Ordinance Information with Exhibits, LSBE Program Information Sheet with LSBE Exhibits, Certificate of Corporate Bidder, Certificate of Authority/Joint Venture, Bidder’s Affidavit of Compliance with O.C.G.A.13-10-91, Reference and Release Form, Subcontractor Tracking Form, Bid Bond and Power of Attorney, Public Works Construction Affidavit and Oath of Successful Bidder, Technical Specifications, and Drawings.

“Bidder” shall mean any person, firm, or corporation submitting a Bid for the Work.

“Bonds” shall mean bid, performance, and payment bonds and other instruments of security, furnished by the Contractor and his surety in accordance with the Contract.

“Change Order” includes the term “amendment” and shall mean a written order authorizing a change in the Work, if applicable, and an adjustment in the Contract Price, Contract Time or Contract Term, as adopted and approved by the Contractor and the DeKalb County Governing Authority, or the Chief Executive Officer, if exempted from Governing Authority adoption and approval in accordance with the express terms of this Contract.

“Contract” or “Agreement” shall consist of the written Contract executed by the parties, all attachments to the Contract, Change Orders, Field Orders, and the Bid Document Package. The intent of these documents is for the Contractor to furnish all materials, appliances, tools, labor and services of every kind necessary for the proper execution of the Work, and the terms and conditions of payment therefore.

“Contract Price” shall mean the total monies payable to the Contractor under the terms and conditions of the Contract.

“Contract Time” shall mean the number of days stated in the Contract for the completion of the Work.

“Contract Term” shall mean the length of time the Contract shall remain in effect.

“Contractor” or “General Contractor” shall mean the individual, firm, joint venture or corporation undertaking the execution of the Work as an independent contractor under the terms of the Contract and acting through his or its agents or employees.

“County” shall mean DeKalb County, Georgia.

“Day(s)” shall mean calendar day(s).

“Drawings” shall mean the part of the Contract which shows, largely through graphical presentation, the characteristics and scope of the Work to be performed and which have been prepared or approved by the County. The Drawings are included in the Bid Document Package.

“Field Order” shall mean a written order issued by an authorized County official/employee to the Contractor during construction effecting a change in the Work by authorizing an addition, deletion, or revision in the Work within the general scope of the Work not involving an adjustment in the Contract Price or a change to the Contract Time or Term. No Field Order shall be valid or effective unless it is signed by the County employee(s) who has been authorized in writing by the Chief Executive Officer or his/her designee to execute Field Orders.

“Notice of Award” shall mean a written notice of the acceptance of the Bid from the County to the successful Bidder.

“Notice to Proceed” shall mean a written communication issued by the County authorizing the Contractor to proceed with the Work and establishing the date of commencement of the Work. The effective date of the Notice to Proceed shall be the date set forth on the Notice to Proceed.

“Project” shall mean the undertaking to be performed as provided in the Contract.

“Shall” is mandatory; “may” is permissive.

“Specifications” or “Technical Specifications” shall mean a part of the Contract consisting of written descriptions of a technical nature regarding materials, equipment, construction systems, standards, and workmanship specified for this Project.

“Subcontractor” shall mean any person, firm, or corporation having a direct contract with the Contractor or with any other Subcontractor for the performance of a part of the Work.

“Submittals” shall mean all shop drawings, diagrams, illustrations, brochures, schedules, samples, and other data which are prepared by the Contractor, a Subcontractor, manufacturer, Supplier, or distributor, which illustrate how specific portions of the Work shall be fabricated or installed.

“Substantial Completion” or “Substantial Completion of the Work” shall mean that date determined by the County when the construction of the Project or an expressly stipulated part thereof is sufficiently completed, in accordance with the Contract, so that the Project or stipulated part can be fully utilized for the purposes for which it is intended.

“Superintendent” shall mean the Contractor’s authorized on-the-job representative designated in writing by the Contractor prior to commencement of any work.

“Supplier” shall mean any person, supplier, or organization who furnishes materials or equipment for the Work, including that fabricated to a special design, but who does not perform labor at the site.

“Work” shall have the meaning assigned to that term in the article in the Contract entitled Scope of Work.”

GR-2. PRIOR USE BY COUNTY

Prior to completion of the Work, the County may take over operation and/or use of the Project or portions thereof. Such prior use of facilities by the County shall not be deemed as acceptance of any Work or relieve the Contractor from any of the requirements of the Contract.

GR-3. CONTRACTOR’S OBLIGATIONS

The Contractor shall, in good workmanlike manner, do and perform all work and furnish all supplies and materials, machinery, equipment, facilities, and all things necessary or proper to perform and complete all the Work within the time herein specified and in accordance with the provisions of this Contract, the Specifications, the Drawings, and any and all supplemental drawings pertaining to the Work. Contractor shall furnish, erect, maintain, and remove such construction, plants, and such temporary works as may be required. Contractor alone shall be responsible for the safety, efficiency, and adequacy of its plant, appliances, and methods, and for any damage which may result from their failure or their improper construction, maintenance, or operation. The Contractor shall observe, comply with, and be subject to all terms, conditions, requirements and limitations imposed by the Contract and local ordinances, and state and federal laws; and shall do, carry on, and complete the entire Work.

GR-4. AUTHORITY OF THE COUNTY

- A. The Contractor shall perform all of the Work under the general direction, and to the entire satisfaction, approval, and acceptance of the County. The County shall decide all questions relating to measurements of quantities, the character and acceptability of the Work performed, and as to whether the rate of progress is such that the Work will be completed within the time limit of the Contract. All questions

as to the meaning of the Drawings and the Specifications will be decided by the County.

- B. The approval of the County of any materials, plant, equipment, Drawings, or of any other items executed, or proposed by the Contractor, shall be construed only to constitute an approval of general design. Such approval shall not relieve the Contractor from the performance of the Work in accordance with the Contract, or from any duty, obligations, performance guarantee, or other liability imposed upon him by the provisions of the Contract.
- C. Whenever in this Contract, the words “directed,” “required,” “permitted,” “ordered,” or words of like import are used, it shall be understood that the direction, requirement, permission, or order of the County is intended, and similar words, “approved,” “acceptable,” “satisfactory,” or words of like import shall mean approved by, acceptable to, or satisfactory to the County.

GR-5. CHANGES IN THE WORK, FIELD ORDERS, AND CHANGE ORDERS

- A. All changes, alterations, or instructions in regard to any feature of the Work that differ from the Drawings and Specifications must be approved in writing by Field Order or Change Order in all cases. No verbal instruction or order will be regarded as a basis for a claim for extra compensation or time.
- B. If a minor change in the Work is found to be necessary due to actual field conditions, the Contractor shall submit detailed drawings and written notification of the problems necessitating such departure for approval by the County before making the change. If the Contractor fails to make such request, no excuse will be entertained thereafter for Contractor’s failure to carry out the Work in the required manner and to provide required guarantees, warranties, and Bonds, and Contractor shall not be entitled to any change in the Contract Price, Contract Time or the Contract Term.
- C. The County may at any time, by issuing a Field Order, make changes in the details of the Work. The Contractor shall proceed with the performance of any changes in the Work so ordered by the County unless such Field Order entitles the Contractor to a change in Contract Price, Time, and/or Term, in which event the Contractor shall give the County written notice thereof within fifteen (15) days after the receipt of the ordered change, and the Contractor shall not execute such changes until it receives an executed Change Order from the County. No extra cost or extension of time shall be allowed unless approved by the County and authorized by execution of a Change Order.
- D. The County may at any time order changes within the scope of the Work without invalidating the Contract.

- E. No claims for extra cost or time will be considered based on an escalation of prices throughout the Contract Term. The value of any work covered by a Change Order or of any claim for increase or decrease in the Contract Price shall be determined by one of the following methods in the order of precedence listed below.
- (1) Unit prices previously approved.
 - (2) An agreed lump sum.
 - (3) The actual cost for labor, direct overhead, materials, supplies, equipment, and other services necessary to complete the changed Work. In addition, there shall be added an amount agreed upon but not to exceed fifteen percent (15%) of the actual cost of such work to cover the cost of general overhead and profit.
- F. The parties' execution of any Change Order constitutes a final settlement of all matters relating to the change in the Work which is the subject of the Change Order, including, but not limited to, all direct or indirect costs associated with such change and any and all adjustment to the Contract Price and the construction schedule. In the event a Change Order increases the Contract Price, Contractor must include the Work covered by such Change Orders in requests for payment as if such Work were originally part of the Contract.

GR-6. TIME FOR COMPLETION

- A. The Contractor understands and agrees that the date of the beginning of Work, rate of progress, and time for completion of the Work are essential conditions of this Contract.
- B. The Contractor agrees that the Work shall be executed regularly, diligently, and uninterrupted at such rate of progress as will insure its full completion thereof within the Contract Time. It is expressly understood and agreed, by and between the Contractor and the County, that the time for the completion of the Work described herein is a reasonable time for the completion of the same, taking into consideration the average climate range and usual industrial conditions prevailing in this locality.
- C. If extraordinary adverse weather conditions are the basis for a claim for additional time, such claim shall be supported by the attachment of records of the National Oceanic and Atmospheric Administration showing meaningful variances from historic trends thereby substantiating the fact that weather conditions were abnormal for the period of time, could not have been reasonably anticipated and had an adverse effect on the scheduled construction activities. The Contractor shall be entitled to an extension of the Contract Time only for extraordinary adverse weather conditions that unavoidably delay activities scheduled at that time, and

then only for the number of days of delay which are due solely to such extraordinary adverse weather conditions. The Contractor is not entitled to any costs associated with extraordinary adverse weather conditions.

- D. The County shall not be liable to the Contractor or any Subcontractor for claims or damages of any nature caused by or arising out of delays, regardless of cause. The sole remedy against the County for delays shall be the allowance of additional time for completion of the Work, the amount of which shall be based on actual and unavoidable delay.

GR-7. SCHEDULES, REPORTS, AND RECORDS

- A. The Contractor shall submit to the County such schedule of quantities and costs, progress schedules, payrolls, reports, estimates, records, and other data as the County may request concerning the Work performed or to be performed. The Contractor shall also submit a schedule of payments that he anticipates earning during the course of the Work.
- B. That Contractor shall coordinate and hold a meeting with its major Subcontractors and the County to discuss the Project schedule. Such meeting shall be held prior to Commencement of the Work under this Contract, but in no event later than ten (10) days after execution of this Contract by all parties. At that meeting, the Contractor shall present a draft Project schedule, and the Contractor and its Subcontractors shall, in collaboration with the County, assist in the preparation of a detailed and specific construction schedule. The Contractor shall be responsible for preparing and updating such schedule, which shall be complete in all respects and shall, when approved by the County, become the Construction Schedule and be automatically incorporated into the Contract and shall not be changed without the prior written consent of the County. The Construction Schedule shall not exceed the Contract Time, shall be revised and updated at appropriate intervals as required by the conditions of the Work and Project, shall be related to the entire Project to the extent required by the Contract, shall utilize Critical Path Method (CPM) software that is compatible with County software, and shall provide for expeditious and practicable execution of the Work. The Construction Schedule shall be cost-loaded.
- C. The Construction Schedule shall, in such detail as the County may require, show the order in which Contractor will carry on the Work, including dates on which the various parts of the Work will start, and the estimated date of completion of each part. It shall also depict all requisite shop drawing submittals and approvals, manufacturing, fabrication, the installation of materials, supplies and equipment, testing, start-up, and training.
- D. The Contractor shall prepare and keep current, for the County's approval, a schedule of submittals which is coordinated with the Construction Schedule and allows the County reasonable time to review submittals. The Contractor shall

perform the Work in general accordance with the most recent schedules submitted to the County.

- E. In the event the County determines that the performance of the Work has not progressed or reached the level of completion required by the Contract, the County will have the right to order the Contractor to take corrective measures necessary to expedite the progress of construction, including, without limitation, (1) working additional shifts or overtime; (2) supplying additional manpower, equipment, and facilities; and (3) other similar measures (hereinafter referred to collectively as "Extraordinary Measures"). Such Extraordinary Measures must continue until the progress of the Work complies with the stage of completion required by the Contract and the Construction Schedule. The County's right to require Extraordinary Measures is solely for the purpose of ensuring the Contractor's compliance with the Construction Schedule. The Contractor is not entitled to an adjustment in the Contract Price for undertaking Extraordinary Measures required by the County. The County may exercise the rights furnished the County under or pursuant to this paragraph as frequently as the County deems necessary to ensure that the Contractor's performance of the Work will comply with the completion date set forth in the Contract as the Contract Time.

GR-8. COUNTY'S RIGHT TO SUSPEND OR TERMINATE WORK

- A. *Termination for Convenience.* County may, for its own convenience and at its sole option, without cause and without prejudice to any other right or remedy of County, elect to terminate the Contract by delivering to the Contractor, at the address listed in the Notices article of this Contract, a written notice of termination specifying the effective date of termination. Such notice shall be delivered to Contractor at least thirty (30) days prior to the effective date of termination.
- B. *Termination for Default.* If the Contractor is adjudged bankrupt or insolvent, or if he makes a general assignment for the benefit of his creditors, or if a trustee or receiver is appointed for the Contractor or for any of his property, or if he files a petition to take advantage of any debtor's act or to reorganize under the bankruptcy or applicable laws, or if he fails to supply sufficient skilled workers or suitable materials or equipment, make payments to Subcontractors or for labor, materials or equipment, or if he disregards laws, ordinances, rules, regulations or orders of any public body having jurisdiction of the Work, or if he otherwise violates any provision of the Contract, then the County may, without prejudice to any other right or remedy, and after giving the Contractor and his surety a maximum of seven (7) days from delivery of a written notice, declare the Contract in default and terminate this Contract. In that event, the County may take possession of the Project and of all materials, equipment, tools, construction equipment and machinery thereon owned by the Contractor. The County may cause the Work to be completed and corrected by whatever method it deems expedient. If called upon by the County to finish the Work, the Contractor's surety shall promptly do so. In any case, the

Contractor and its surety shall be liable to the County for any and all damages and costs incurred by the County as a result of any default by the Contractor, including without limitation all costs of completion or correction of the Work, liquidated damages, attorneys' fees, expert fees, and other costs of dispute resolution. Termination of this Contract pursuant to this paragraph may result in disqualification of the Contractor from bidding on future County contracts for a period of time not to exceed five (5) years.

- C. If Contractor's services are terminated by the County pursuant to paragraph A or B in this General Requirement, the termination will not affect any rights or remedies of the County then existing or which may thereafter accrue against Contractor or its surety. Any retention or payment of moneys due Contractor by County will not release Contractor from liability. If it is determined that the Contractor was not in default or that the failure to perform is excusable, a termination for default will be considered to have been a termination for the convenience of the County, and the rights and obligations of the parties shall be governed accordingly.
- D. In case of termination of this Contract before completion of the Work, Contractor will be paid only for materials and equipment accepted by the County and the portion of the Work satisfactorily performed through the effective date of termination as determined by the County.
- E. Except as otherwise provided in this General Requirement, neither party shall be entitled to recover lost profits, special, consequential or punitive damages, attorney's fees or costs from the other party to this Contract for any reason whatsoever.
- F. The parties' obligations pursuant to this General Requirement shall survive any Acceptance of Work, or expiration or termination of this Contract.

GR-9. FINAL INSPECTION

Upon notice from the Contractor that the Work is completed, the County shall make a final inspection of the Work and shall notify the Contractor of all instances where the Work fails to comply with the Drawings and Specifications, as well as any defects the County may discover. At no cost to the County, the Contractor shall immediately make such alterations as are necessary to bring the Work into compliance with the Contract, the Drawings, and Specifications.

GR-10. WARRANTIES, GUARANTEES AND CORRECTION OF WORK

- A. The Contractor warrants to the County that materials and equipment furnished under the Contract will be new and of good quality, unless otherwise required or permitted by the Contract; that the Work will be free from defects not inherent in the quality required or permitted; and that the Work will conform to the

requirements of the Contract. Work not conforming to these requirements, including substitutions not properly approved and authorized, is considered defective. The County, in its sole discretion, may exclude from the Contractor's warranty; remedies for damage or defect which the County determines were caused by abuse; modifications not executed by the Contractor; improper or insufficient maintenance; improper operation; and normal wear and tear and normal usage.

- B. Upon the completion of the Work, and as a condition of final payment, the Contractor shall guarantee in writing that all Work has been accomplished in conformance with the Contract. If required by the County, the Contractor shall also furnish additional satisfactory evidence as to the kind and quality of materials and equipment.
- C. The Contractor shall promptly, and in no event later than 48 hours after receiving written demand from the County, remedy any error, omission, defect, or non-compliance in the Work discovered by the County during construction or at any time thereafter until one year after the final completion of the Work. Nothing herein shall be deemed to shorten any statutory period of limitation otherwise applicable to any legal action by the County against the Contractor.
- D. Contractor shall pay for any damage caused by any omission or defect in the Work, including without limitation, any damage to other improvements or facilities. In the event that the Contractor should fail to timely make repairs, adjustments, or other remedy that may be made necessary by such defects, the County may do so, and charge the Contractor the cost thereby incurred.
- E. All warranties and guaranties shall extend for the greatest of one (1) full year commencing on the dates of Substantial Completion of the Project or such longer period of time as is required by the Contract. The one (1) year period shall be extended with respect to portions of the Work first performed after Substantial Completion for a period of one (1) year after the actual performance of the Work. If any defect or deviation should exist, develop, be discovered or appear within such one (1) year period, the Contractor, at its sole cost and expense and immediately upon demand, shall fully and completely repair, correct, and eliminate such defect. The foregoing warranties and guarantees are cumulative of and in addition to, and not restrictive of or in lieu of, any and all other warranties and guarantees provided for or required by law. No one or more of the warranties contained herein shall be deemed to alter or limit any other. The Performance Bond shall remain in full force and effect throughout the applicable guarantee period set forth in this paragraph.
- F. Neither the final payment nor any provision of the Contract, nor partial or entire occupancy or use of the Work by the County, shall constitute an acceptance of any part of the Work that is not in accordance with the Contract or relieve the Contractor of liability for incomplete or faulty materials or workmanship.

- G. All manufacturer warranties and guarantees shall be delivered to the County prior to Substantial Completion and such delivery shall be a condition precedent to the issuance of the Certificate of Substantial Completion. Before final payment, the Contractor shall assign and transfer to the County all guarantees, warranties and agreements from all contractors, Subcontractors, vendors, Suppliers, or manufacturers regarding their performance, quality of workmanship or quality of materials supplied in connection with the Work. The Contractor represents and warrants that all such guarantees, warranties and agreements will be freely assignable to the County, and that upon final completion of the Work, all such guarantees, warranties and agreements shall be in place and enforceable by the County in accordance with their terms. Contractor's obligations pursuant to this General Requirement shall survive any acceptance of Work, or termination or expiration of this Contract.

GR-11. CONTRACTOR'S PERSONNEL AND INDEPENDENT CONTRACTOR STATUS

- A. The Contractor will supervise and direct the Work, including the Work of all Subcontractors. Contractor will be solely responsible for the means, methods, techniques, sequences, and procedures of construction. An experienced Superintendent and necessary assistants competent to supervise the particular types of work involved shall be assigned to the Project by the Contractor and shall be available at all times when work is in progress. The name of the Superintendent shall be submitted with qualifications of same prior to the start of the Work. If approved by the County, the Superintendent so named by the Contractor shall be employed by the Contractor and shall have served in a supervisory capacity on at least one Project of like description and size performed by the Contractor during the previous twelve months. Under no circumstances shall an employee of any Subcontractor serve as the Superintendent, unless approved by the County prior to being named Superintendent. The Superintendent shall represent the Contractor, and all directions given to the Superintendent shall be as binding as if given to the Contractor. Important communications shall be confirmed in writing. Other communications shall be similarly confirmed on written request in each case.
- B. The Contractor shall not change key members of its staff without the prior consent of the County, unless such staff members prove to be unsatisfactory to the Contractor and cease to be in its employ. If the Contractor intends to change a key staff member (defined as certain full-time personnel stationed at the site including Project Manager, Superintendent, Project Engineer, Assistant Project Manager, Assistant Superintendent, or Assistant Project Engineer) it shall give the County written notice at least fifteen (15) days prior to the intended change. The written notice shall include a description of qualifications for the new proposed key staff member. The County shall have the right to approve or disapprove the proposed key staff member.

- C. Only persons skilled in the type of work which they are to perform shall be employed. The Contractor shall, at all times, maintain discipline and good order among his employees, and shall not employ any unfit person or persons or anyone unskilled in the work assigned him.

- D. The relationship between the County and the Contractor shall be that of owner and independent contractor. Other than the consideration set forth herein, the Contractor, its officers, agents, servants, employees, and any Subcontractors shall not be entitled to any County employee benefits including, but not limited to social security, insurance, paid annual leave, sick leave, worker's compensation, free parking or retirement benefits. All services provided by Contractor shall be by employees of Contractor or its Subcontractors and subject to supervision by Contractor. No officer or employee of Contractor or any Subcontractor shall be deemed an officer or employee of the County. Personnel policies, tax responsibilities, social security payments, health insurance, employee benefits and other administrative policies, procedures or requirements applicable to the Work or services rendered under this Contract shall be those of the Contractor, not the County.

GR-12. SUBCONTRACTING

- A. The Contractor understands and agrees that it shall be a breach of this Contract to subcontract any portion of the Work on this Project unless
 - 1. The Work and the Subcontractor proposed to perform it have been declared in the Bid to the Contract; or
 - 2. The Contractor shall have obtained advance written approval from the County.

- B. The Contractor further understands and agrees that any work on this Project, which the Contractor secures in violation of this General Requirement, shall be deemed a donation from the Contractor for which the County shall not be obligated to pay. Nothing contained in this Contract shall create any contractual relation between any Subcontractor and the County. Upon request, Contractor shall provide the County with copies of each of its contract(s) and amendments with each Subcontractor.

- C. Nothing contained in this Contract shall create, nor be interpreted to create privity, or any other relationship whatsoever, between the County and any person, or entity or than Contractor.

GR-13. ASSIGNMENTS

The Contractor agrees it shall not sublet, assign, transfer, pledge, convey, sell, or otherwise dispose of the whole or any part of this Contract or his right, title, or interest therein to any person,

firm, or corporation without the previous written consent of the County. If the County consents to any such assignment or transfer, then the Contractor binds itself, its partners, successors and assigns to all covenants of this Contract.

GR-14. INDEMNIFICATION AND HOLD HARMLESS

- A. The Contractor shall be responsible from the execution date or from the time of the beginning of the Work, whichever shall be the earlier, for all injury or damage of any kind resulting from the Work, to persons or property, including employees and property of the County. The Contractor shall exonerate, indemnify, and save harmless the County, its elected officials, officers, employees, agents and servants, hereinafter collectively referred to in this General Requirement as “the County Indemnitees,” from and against all claims or actions based upon or arising out of any damage or injury (including without limitation any injury or death to persons and any damage to property) caused by or sustained in connection with the performance of this Contract or by conditions created thereby or arising out of or any way connected with Work performed under this Contract, as well as all expenses incidental to the defense of any such claims, litigation, and actions. Furthermore, Contractor shall assume and pay for, without cost to the County Indemnitees, the defense of any and all claims, litigation, and actions suffered through any act or omission of the Contractor, or any Subcontractor, or anyone directly or indirectly employed by or under the supervision of any of them. Notwithstanding any language or provision in this Contract, Contractor shall not be required to indemnify any County Indemnitee against claims, actions, or expenses based upon or arising out of the County Indemnitee’s sole negligence.
- B. As between the County Indemnitees and the Contractor as the other party, the Contractor shall assume responsibility and liability for any damage, loss, or injury, including death, of any kind or nature whatever to person or property, resulting from any kind of claim made by Contractor’s employees, agents, vendors, Suppliers or Subcontractors caused by or resulting from the performance of Work under this Contract, or caused by or resulting from any error, omission, or the negligent or intentional act of the Contractor, vendors, Suppliers, or Subcontractors, or any of their officers, agents, servants, or employees. The Contractor shall defend, indemnify, and hold harmless the County Indemnitees from and against any and all claims, loss, damage, charge, or expense to which they or any of them may be put or subjected by reason of any such damage, loss, or injury.
- C. The Contractor expressly agrees to provide a full and complete defense against any claims brought or actions filed against the County Indemnitees, where such claim or action involves, in whole or in part, the subject of the indemnity contained in this Contract, whether such claims or actions are rightfully or wrongfully brought or filed. The County has the sole discretion to choose the counsel who will provide the defense.
- D. No provision of this Contract and nothing herein shall be construed as creating any

individual or personal liability on the part of any elected official, officer, employee, agent or servant of the County, nor shall the Contract be construed as giving any rights or benefits hereunder to anyone other than the parties to this Contract.

- E. The parties agree that Contractor shall be liable for all fines or civil penalties, which may be imposed by any local, federal or state department or regulatory agency that are a result of Contractor's performance of the Work under this Contract. Contractor shall pay the costs of contesting any such fines. The parties' obligations pursuant to this General Requirement shall survive any acceptance of Work, or termination or expiration of this Contract.

GR-15. ROYALTIES AND PATENTS

The Contractor shall hold and save the County and its elected officials, officers, agents, servants, and employees harmless from liability of any nature or kind, including cost and expenses for, or on account of, any patented or unpatented invention, process, article, or appliance manufactured or used in the performance of the Contract, including its use by the County, unless otherwise specifically stipulated in the Contract.

GR-16. LAWS AND REGULATIONS

- A. The Contractor's attention is directed to the fact that all applicable federal, state, and County laws, municipal ordinances, and the rules and regulations of all authorities having jurisdiction over construction of the Project shall apply to the Contract throughout, and they will be deemed to be included in the Contract the same as though herein written out in full. The Contractor shall keep itself and its employees and Subcontractors fully informed of all laws, ordinances, and regulations in any manner affecting those engaged or employed in the Work or the materials used in the Work or in any way affecting the conduct of the Work and of all orders and decrees of bodies or tribunals having any jurisdiction or authority over same. If Contractor discovers any discrepancy or inconsistency in this Contract or in the Drawings or Specifications in relation to any such law, regulation, ordinance, order, or decree, Contractor shall promptly report the same, in writing, to the County. Contractor shall at all times observe and comply with all such laws, ordinances, and regulations, and shall protect and indemnify the County and its agents against any all damages and claims arising out of any violation of such law, ordinance, regulation, order, or decree, whether by Contractor or its employees or Subcontractors.
- B. Contractor shall not discriminate against any person in its operations, activities or performance of Work under this Contract. Contractor shall affirmatively comply with all applicable provisions of federal, state and local equal employment laws and shall not engage in or commit any discriminatory practice against any person based on race, age, religion, color, gender, national origin, physical or mental disability, or political affiliation. Contractor shall maintain a Drug Free Workplace.

GR-17. PERMITS AND INSPECTION FEES

- A. Permits shall be secured by the Contractor, and inspections will be required, but the County will not charge the Contractor for permits and inspections obtained from the County. The Contractor shall secure and pay for any permits and inspection fees required by any other governmental entity or agency.

- B. Prior to execution of this Contract, Contractor shall provide the County with a copy of its current, valid business license. If Contractor is not a Georgia corporation, Contractor shall submit a certificate of authority to transact business in the state of Georgia and a copy of their valid business license issued by their home jurisdiction. Contractor shall provide the County with copies of all other required licenses, certifications and permits for the Contractor and/or all of Contractor's employees, personnel, agents or Subcontractors performing services that require licensure by the federal government, the State of Georgia, or the County. Contractor hereby warrants and represents that at all times during the Contract Term it shall maintain in good standing all required licenses, certifications, and permits required under federal, state and local laws necessary to perform the services required by this Contract.

GR-18. LAND AND RIGHTS-OF-WAY

Prior to entering on any land or right-of-way, the Contractor shall ascertain the requirements of applicable permits or easements obtained by the County and shall conduct his work in accordance with requirements thereof, including the giving of notice. The Contractor shall be fully responsible for performing work to the requirements of any permit or easement granting entity, even though such requirements may exceed or be more stringent than that otherwise required by the Contract, and shall compensate the County fully for any loss or expense arising from failure of the Contractor to perform as required by such entity. The Contractor shall provide, at its own expense without liability to the County, any additional land and access thereto that the Contractor may desire for temporary construction facilities, or for storage of materials.

GR-19. PROTECTION OF WORK, PROPERTY, AND PERSONS

- A. The Contractor is responsible for initiating, maintaining, and supervising all safety precautions and programs in connection with the Work. Contractor shall take all necessary precautions for the safety of, and will provide the necessary protection to prevent damage, injury or loss to all employees on the Project and other persons who may be affected thereby, all the Work and all materials or equipment to be incorporated therein, whether in storage on or off the site, and other property at the site or adjacent thereto, including trees, shrubs, lawns, lakes, drainage ways, walks, pavements, roadways, structures, and utilities not designated for removal, relocation or replacement in the course of construction.

- B. The Contractor shall erect and maintain, as required by the conditions and progress of the Work, all necessary warning safeguards for devices and the safety and protection of the Work, the public and adjoining property.
- C. If existing utilities or structures are indicated by the Contract, no warranty is made as to the accuracy or completeness of such indication or the information provided regarding such utilities or structures. The Contractor shall comply with all applicable state law concerning the marking and location of existing utilities. The Contractor shall, prior to commencing other on-site work, accurately locate above and below ground utilities and structures, which may be affected by the Work, using whatever means may be appropriate, and shall verify the nature and condition of such utilities and structures. The Contractor shall mark the location of existing utilities and structures, if they are not otherwise readily visible, with flagging, stakes, barricades, or other suitable means, and shall preserve and protect all utilities and structures not designated for removal, relocation, or replacement in the course of construction. Contractor shall notify the County promptly of discovery of any conflict between the Contract and any existing facility.
- D. All existing utilities, both public and private, including but not limited to, sewer, gas, water, electrical, and telephone services, shall be protected and their operation shall be maintained through the course of the Work. Any temporary shutdown of an existing service shall be arranged between the Contractor and the responsible agency. The Contractor shall assume full responsibility and hold the County harmless from the result of any damage that may occur as a result of the Contractor's activities in this regard.
- E. In emergencies affecting the safety of persons or the Work or property at the site or adjacent thereto, or unanticipated conditions where delay would substantially impact the time or cost of work, the Contractor, upon notification to the County, shall act to prevent threatened damage, injury, or loss. Any claim for compensation or extension of time by the Contractor due to such extra work shall be submitted to the County within ten (10) days of the date of performing such work or deviations in the manner prescribed for a Change Order.

GR-20. PROHIBITED INTERESTS

No official of the County who is authorized in such capacity and on behalf of the County to negotiate, make, accept, or approve, or to take part in negotiating, making, accepting, or approving any architectural, engineering, inspection, construction, or material supply contract, or any subcontract in connection with the construction of the Project, shall become directly or indirectly interested personally in this Contract or in any part hereof. No officer, employee, architect, attorney, engineer, or inspector of or for the County who is authorized in such capacity and on behalf of the County to exercise any legislative, executive, supervisory, or other similar functions in connection with the construction of the Project, shall become directly or indirectly interested personally in this Contract or in any part thereof, any material supply contract, subcontract, insurance contract, or any other contract pertaining to the Project.

GR-21. FIRST SOURCE JOBS ORDINANCE

The Contractor is required to comply with the DeKalb County First Source Jobs Ordinance, Code of DeKalb County as Revised 1988, section 2-231 *et seq.*, and among other things, is required to make a good faith effort to hire DeKalb County residents for at least fifty percent 50% of all jobs created by an Eligible Project, as that term is defined in the First Source Ordinance, using the First Source Registry.

GR-22. FOREIGN CORPORATIONS

In the event the Contractor is a foreign corporation, partnership, or sole proprietorship, the Contractor hereby irrevocably appoints the Georgia Secretary of State as its agent for service of all legal process for the purposes of this Contract only.

GR-23. SPECIFICATIONS AND DRAWINGS

- A. The Specifications, the Drawings and the Contract shall be supplementary to each other, and any material, workmanship, and/or service which may be in one, but not called for in the others, shall be as binding as if indicated, called for, or implied by all.
- B. Each section or type of work is described separately in the Technical Specifications; however, should any item of material, equipment, work, or combinations of such be required in one section, and not be described in that section and a similar item described in another section, that description shall apply regardless of the section under which it is described.
- C. Any discrepancies found between the Drawings and Specifications and site conditions, or any inconsistencies or ambiguities in the Drawings or Specifications shall be immediately reported to the County, in writing, who shall promptly correct such inconsistencies or ambiguities in writing. Work done by the Contractor after his discovery of such discrepancies, inconsistencies, or ambiguities shall be done at the Contractor's risk.
- D. Upon award of the Contract, the Contractor will be supplied, free of charge, up to three complete sets of the Contract Drawings and Specifications. Any prints and Specifications in excess of these shall be furnished at cost at the Contractor's expense.
- E. The Contractor shall furnish, with reasonable promptness, all samples as directed by the County for approval for conformance with the design concept of the Project and for compliance with the information stated in the Contract. The Work shall be in accordance with approved samples.

- F. The County may, without changing the scope of the Work, furnish the Contractor additional instructions and detail drawings, as necessary to carry out the Work required by the Contract. The additional drawings and instructions thus supplied will become a part of the Contract. The Contractor shall carry out the Work in accordance with the additional detail drawings and instructions.
- G. Attention is directed to the fact that the detailed Specifications and separate sections may be written in short or abridged form. In regard to every section of the Specifications and all parts thereof, mentioned therein, or indications on the Drawings of articles, materials, operations, or methods, requires that the Contractor:
- (1) Provide each item mentioned and indicated of a quality or subject to qualifications noted;
 - (2). Perform according to conditions stated, each operation prescribed; and
 - (3) Provide therefore all necessary labor, equipment, and incidentals.
- H. For convenience of reference and to facilitate the letting of contracts and subcontracts, these Specifications are separated into titled sections. Such separation shall not, however, operate to make the County an arbiter to establish limits for the contracts between the Contractor and Subcontractors.
- I. Notwithstanding the appearance of such language in the various sections of the Specifications as, "The Paving Contractor," "The Grading Contractor," etc., the Contractor is responsible to the County for the entire Contract and the execution of all Work referred to in the Contract.

GR-24. CONTRACTOR'S SUBMITTALS

- A. The Contractor shall submit all Submittals to the official or employee so designated by the chief executive officer all Submittals as required under the Specifications and in such time and manner that will allow at least ten (10) days for the County's review, pursuant to the Construction Schedule. No portion of the Work shall commence until all Submittals relating to such portion have been approved by the County.
- B. The approved Drawings will be supplemented by such shop drawings as are needed to adequately control the Work. Shop Drawings, product data, samples and other Submittals are not parts of the Contract. The purpose of their submittal is to demonstrate for those portions of the Work for which Submittals are required by the Contract, the way by which the Contractor proposes to conform to the information given and the design concept expressed in the Contract. Informational Submittals, upon which a County employee, the Architect or Engineer, if retained by the County in connection with the Project, is not expected to take responsive

action, may be so identified in the Contract. Submittals which are not required by the Contract may be returned by the County without action. The approval of a Submittal shall not authorize any deviation from or alteration of the Drawings or Specifications absent a Change Order or Field Order.

- C. Shop drawings to be furnished by the Contractor for any structure shall consist of such detailed drawings as may be required for the execution of the Work.
- D. Drawings for false work, centering, and form work may also be required per the Specifications and in such cases shall be likewise subjected to approval unless approval is waived.
- E. The County's review will be within reasonable promptness as to cause no delay in the Work. Approval of the Contractor's Submittals does not relieve the Contractor of any responsibility for accuracy of dimensions and details or from otherwise ensuring that the Work complies with the requirements of the Contract. It is mutually agreed that the Contractor shall be responsible for agreement and conformity of Submittals with the Drawings and Specifications. The County will review and approve or take other appropriate action upon the Contractor's Submittals such as shop drawings, product data and samples, but only for the limited purpose of checking for conformance with information given and the design concept expressed in the Contract. Review of submittals is not conducted for the purpose of determining the accuracy and completeness of details such as dimensions and quantities, or for substantiating instructions for installation or performance of equipment or systems, all of which remain the responsibility of the Contractor as required by the Contract. The County's review shall not constitute approval of safety precautions or of any construction means, methods, techniques, sequences or procedures. The County's approval of a specific item shall not indicate approval of an assembly of which the item is a component.
- D. It is the responsibility of the Contractor to check all Submittals before same are submitted to the County for approval. Submittals which have not been checked and approved by the Contractor will not be reviewed by the County.
- E. Submittals shall be submitted only by the Contractor who shall indicate by a signed stamp on the drawings that he has checked the Submittals and that the work shown on them is in accordance with Contract requirements and has been checked for dimensions and relationship with work of all other trades involved. Under no conditions shall Submittals be accepted from anyone other than the Contractor.
- F. The Contractor shall furnish the County with at least six copies of all Submittals for approval. Two finally approved copies will be returned to the Contractor for his use. The Contract Price shall include the cost of furnishing all Submittals and the Contractor will be allowed no extra compensation for such drawings.

- G. The approval of such Submittals shall not relieve the Contractor from responsibility for deviations from Drawings or the Specifications unless he has in writing called attention to such deviations, and the County has approved the changes or deviations in writing at the time of submission, nor shall it relieve him from the responsibility for errors of any kind in Submittals. When the Contractor does call such deviations to the attention of the County, he shall state in writing whether or not such deviations involve any extra cost. If this is not mentioned, it will be assumed that no extra cost is involved for making the change.
- H. The Contractor shall prepare and maintain a log of all Submittals which includes, at a minimum, the submittal number, revision number, description, responsible company, proposed submittal date, date actually submitted, date approved, any comments received, approval status, and resubmittal information. The log shall be updated at least on a monthly basis and made available to the County for review upon request.

GR-25. AS-BUILT DRAWINGS

The Contractor shall maintain a red-lined set of drawings on site during the progress of the Work, indicating any Field Orders, Change Orders and the location of the portion of the Work or equipment actually installed. The Contractor shall, upon completion of the Work, furnish a marked set of reproducible drawings indicating any field changes and the location of Work as actually installed, if different from the requirements of the Contract, and deliver them to the County in hard copy as well as an electronic copy compatible with the County's software and hardware system.

GR-26. EXAMINATION OF WORK BY CONTRACTOR

It is understood and agreed that the Contractor has, by careful examination, satisfied himself as to the nature and location of the Work, the configuration of the ground, the character, quality, and quantity of the facilities needed preliminary to and during the prosecution of the Work, the general and local conditions, and all other matters which can in any way affect the Work or the cost thereof under this Contract.

GR-27. INSPECTION AND TESTING OF MATERIALS

Unless otherwise specifically provided for, the inspection and testing of materials and finished articles to be incorporated in the Work as required by the Specifications shall be made by the County, or bureaus, laboratories, or agencies selected by the County. The cost of such inspection and testing shall be paid by the Contractor unless County agrees to pay the cost. Materials and finished articles shall have passed the required tests prior to the incorporation of such materials and finished articles in the Work. The County may require, and the Contractor shall furnish if required to do so, certificates from manufacturers to the effect that the products or materials furnished by them for use in the Work comply with the applicable specified requirements for the materials or products being furnished.

GR-28. INSPECTION OF WORK

- A. The Contractor shall, at all times, permit and facilitate inspection of the Work by authorized representatives of the County and public authorities having jurisdiction in connection with the Work of this Contract. The presence or observations of the County or its representative at the site of the Work shall not be construed to, in any manner, to relieve the Contractor of its responsibility for strict compliance with the provisions of the Contract.
- B. If the Drawings, Specifications, County's instructions, laws, ordinances, or a public authority require any work to be specially tested or approved, the Contractor shall give the County timely notice of its readiness for observation or inspection. If the inspection is by another authority, then the County shall be advised of the date fixed for such inspection. Required certificates of inspection shall be secured by the Contractor. Contractor, having secured all certificates of inspection, will deliver same to the County upon completion. If any Work should be covered up without approval or consent of the County, it shall, if required by the County, be uncovered for examination at the Contractor's expense. The recovering of such Work after inspection shall be at Contractor's expense.
- C. Should any disagreement or difference arise as to the estimate, quantities, or classifications or as to the meaning of the Drawings or Specifications, or any point concerning the character, acceptability, and nature of the several kinds of work, any materials and construction thereof, the decisions of the County shall be final and conclusive and binding upon all parties to the Contract.
- D. If the County determines that portions of the Work require additional testing, inspection or approval beyond the requirements of the Specifications, the County will instruct the Contractor to make arrangements for such additional testing, inspection or approval by an entity acceptable to the County, and the Contractor shall give timely notice to the County of when and where tests and inspections are to be made so that the County may be present for such procedures. Such costs, except as provided below, shall be at the County's expense.
- E. If such procedures for testing or inspection reveal failure of the portions of the Work to comply with requirements established by the Contract, all costs made necessary by such failure including those of repeated procedures shall be at the Contractor's expense.
- F. Required certificates of testing, inspection or approval shall, unless otherwise required by the Contract, be secured by the Contractor and promptly delivered to the County or the Architect if one is retained by the County in connection with the Project. Tests or inspections conducted, pursuant to the Contract, shall be made promptly to avoid unreasonable delay in the Work.

GR-29. REQUESTS FOR SUBSTITUTIONS

- A. Requests for substitutions of proprietary products or of a particular manufacturer, vendor, or Subcontractor must be accompanied by the following documentation:
- (1) Full explanation of the proposed substitution and submittal of all supporting data including technical information, catalog cuts, warranties, test results, installation instructions, operating procedures, and other like information necessary for a complete evaluation of the substitution;
 - (2) Reasons the substitution is advantageous or necessary, including benefits to the County and the Work in the event the substitution is acceptable;
 - (3) The adjustment, if any, in the Contract Price, in the event the substitution is acceptable;
 - (4) The adjustment, if any, in the Contract Term or Time and the construction schedule in the event the substitution is acceptable;
 - (5) An affidavit stating that (1) the proposed substitution conforms and meets all the requirements of the pertinent Specifications and the requirements shown on the Drawings and (2) the Contractor accepts the warranty and correction obligations in connection with the proposed substitution as if originally specified;
 - (6) Proposals for substitutions must be submitted in triplicate to the County in sufficient time to allow the County no less than ten (10) working days for review; and
 - (7) No substitutions will be considered or allowed without the Contractor's submittal of complete substantiating data and information as stated hereinbefore.
- B. Substitutions and alternates may be rejected at the County's discretion without explanation and will be considered only under one or more of the following conditions:
- (1) Required for compliance with interpretation of code requirements or insurance regulations then existing;
 - (2) Unavailability of specified products, through no fault of the Contractor; or
 - (3) Subsequent information discloses inability or specified products to perform properly or to fit in designated space;
 - (4) Manufacturer/fabricator refuses to certify or guarantee performance of specified product as required; and

- (5) When in judgment of the County, that a substitution would be substantially to the County's best interests, in terms of costs, time, or other considerations.
- C. Whether or not any proposed substitution is accepted by the County, the Contractor must reimburse the County for any fees charged by the Architect or other consultants for evaluating each proposed substitute. By making requests for substitutions based on the above, the Contractor:
- (1) Represents and warrants that the Contractor has personally investigated the proposed substitute product or Subcontractor and determined that it is equal or superior in all respects to the product or Subcontractor previously specified;
 - (2) Represents and warrants that the Contractor will provide the same warranty for the substituted product or for the workmanship of the substituted Subcontractor, as applicable, that the Contractor would have provided for the product or Subcontractor previously specified;
 - (3) Certifies that the cost data presented, in the form of certified quotations from Suppliers of both specified and proposed equipment is complete and includes all related costs under this Contract, but excludes costs under separate contracts, and waives all claims for additional costs related to the substitution which subsequently become apparent; and
 - (4) Agrees that the Contractor will coordinate the installation of the accepted substitution, making such changes as may be required for the Work to be complete and in accordance with the Contract in all respects.
- D. Contractor shall not propose an item for substitution unless it is equal to or superior to the specified item or items in construction, efficiency, and utility. The opinion of the County as to the equality or superiority of the item shall be final, and no substitute material or article shall be purchased or installed without the County's written approval.
- E. In case of a difference in price, the County shall receive all benefits of the difference in cost involved in any substitution, when lower, and the Contract altered by Change Order to credit the County with any savings to be obtained. However, the County shall not be charged for any additional cost in the case of a price increase.

GR-30. REJECTIONS OF WORK AND MATERIALS

- A. All Work that is defective or deviates from the Drawings or Specifications will be rejected. All rejected Work shall be replaced immediately with other material, equipment, or work which conforms with the Drawings and Specifications at no additional cost to the County. If rejected Work is not removed within forty-eight hours from the date of letter of notification, the County shall have the right and

authority to stop the Work immediately and/or to arrange for the removal of said rejected Work at the cost and expense of the Contractor.

- B. Inspection of the Work shall not relieve the Contractor of any of its obligations, and defective Work shall be made good regardless of whether it has been previously inspected by the County and accepted or estimated for payment. The failure of the County to reject or condemn improper materials or workmanship shall not be considered as a waiver of any defect that may be discovered later.

GR-31. MATERIALS, SERVICES, AND FACILITIES

- A. The Contractor shall at all times employ sufficient labor and equipment for executing the Work to full completion in the manner and time specified. Failure of the Contractor to provide adequate labor and equipment shall constitute a default of the Contract. The labor and equipment to be used in the Work by the Contractor shall be sufficient to meet the requirements of the Work and shall be such as to produce a satisfactory quality of work in accordance with accepted industry practices and within the Contract Time.
- B. Materials and equipment shall be so stored and handled as to insure the preservation of their quality and fitness for the Work. Stored materials and equipment to be incorporated in the Work shall be located so as to facilitate prompt inspection. No product which has in any way become unfit for the intended purpose shall be incorporated into the Work.
- C. Manufactured articles, materials, and equipment shall be applied, installed, connected, erected, cleaned, and conditioned as directed by the manufacturer. Contractor shall promptly notify the County of any conflict between the instructions of any manufacturer and the requirements of the Drawings or the Specifications.
- D. Materials, supplies, and equipment to be incorporated into the Work shall be new and unused unless otherwise specifically stated in the Contract. The source of supply for all such products shall be submitted to the County, together with detailed descriptions thereof in the form of samples, shop drawings, tests, or other means necessary to adequately describe the items proposed. Approval by the County of a manufacturer or supplier shall not constitute the approval of materials, supplies, or equipment obtained from such manufacturer or supplier if they do not comply with the requirements of the Contract. If, after trial or installation, it is found that sources of supply, even though previously approved by the County, have not furnished products meeting the intent of the Contract, the Contractor shall thereafter furnish products from other approved sources, and shall remove completed Work incorporating products which do not meet Contract requirements.
- E. The Contractor shall confine operations to areas permitted by law, ordinances, permits and the Contract, and shall not unreasonably encumber the site with materials or equipment. The Contractor shall provide parking for all

construction vehicles only within the construction limits as indicated on the drawings or make appropriate arrangements as permitted by law.

- F. Only materials and equipment which are to be used directly in the Work may be brought to and stored on the Project site by the Contractor. After equipment is no longer required for the Work, it must be promptly removed from the Project site. Protection of construction materials and equipment stored at the Project site from weather, theft, damage, and all other adversity is the sole responsibility of the Contractor.
- G. The Contractor and any entity for which the Contractor is responsible must not erect any sign on the Project site without the prior written consent of the County, which may be withheld in the sole discretion of the County.
- H. Contractor must ensure that the Work, at all times, is performed in a manner that affords reasonable access, both vehicular and pedestrian, and for emergency response to the site of the Work and all adjacent areas. The Work must be performed, to the fullest extent reasonably possible, in such a manner that public areas adjacent to the site of the Work are free from debris, building materials and equipment likely to cause hazardous conditions. Without limitation of any other provision of the Contract, Contractor must use its best efforts to minimize any interference with the occupancy or beneficial use of any areas and buildings adjacent to the site of the Work, or the Project.
- I. Without prior approval of the County, the Contractor shall not permit any worker to use any existing facilities at the Project site, including, without limitation, lavatories, toilets, entrances, and parking areas other than those designated by the County for such use. Without limitation of any other provision of the Contract, the Contractor shall use its best efforts to comply with all rules and regulations promulgated by the County in connection with the use and occupancy of the Project site, as amended from time to time. The Contractor shall immediately notify the County in writing if during the performance of the Work, the Contractor finds compliance with any portion of such rules and regulations to be impracticable, setting forth the problems that may be caused by such compliance and suggesting alternatives through which the results intended by such portions of the rules and regulations can be achieved. The County may, in the County's sole discretion, adopt such suggestions, develop new alternatives or require compliance with the existing requirements of the rules and regulations. The Contractor shall also comply with all insurance requirements applicable to the use and occupancy of the Project site.
- J. Unless otherwise provided in the Contract, Contractor shall provide and maintain a suitable office on the site for its own use and for the use of representatives of the County. Contractor shall furnish sufficient heat, artificial light, ventilation and janitor's service, and shall also provide a table or desk, plan rack and chairs, all for the use of those visiting the job, in addition to such furnishings as he provides for

his own use. Temporary offices and other structures shall be located where approved by the County, and shall be removed from the premises upon completion of the Contract or earlier if so, directed by the County.

- K. Contractor may be required by the County, at the beginning of Work, to provide, at the Project site, suitable and adequate temporary toilets and enclosure for use of workers on the job, shall maintain same in sanitary condition, and shall remove same at the completion of construction operations and/or when directed by the County. Contractor shall not allow any sanitary nuisances to be committed in or about the site and shall enforce sanitary regulations of local and state health authorities.
- L. The Contractor shall cooperate with the County in any required use of the property and arrange for storage of materials on the Project site in such areas as are mutually agreed upon. The Contractor shall allot suitable and proper space to its Subcontractors for the storing of their materials and for the erection of their sheds and tool houses. Should it be necessary at any time to move materials, sheds, or storage platforms, the Contractor shall, at its own expense move same as and when directed by the County.
- M. Unless otherwise instructed by the County, the Contractor shall repair and return to original condition all buildings, streets, curbs, sidewalks, utilities or other facilities affected by the Contractor's performance of the Work. The County's decisions in matters relating to aesthetic effect shall be final if consistent with the intent of the Contract.

GR-32. UTILITIES DURING CONSTRUCTION

Contractor shall furnish all utilities and pay for all bills for utilities used during construction. Utilities shall include electric power, fuel of any sort used for heating, etc., telephone services, cable and internet, if necessary, and water. Contractor shall provide all temporary connections to utilities when not provided by the utility company or others at no additional cost to the County. Contractor shall, if required by the County, install and maintain at his own expense, a job telephone and communications equipment necessary for the execution of the Work for the Contract Time.

GR-33. TEMPORARY HEAT AND AIR CONDITIONING

The Contractor shall provide, at his own expense, temporary heat or air conditioning, as necessary, to protect all Work and materials against injury from heat, dampness or cold. Fuel, equipment and method of heating and cooling shall be satisfactory to the County and shall not present a fire hazard. Contractor shall comply with the requirements in the Specifications for specific temperatures to be maintained.

GR-34. MAINTENANCE MANUAL

Contractor shall, prior to completion of Contract, deliver to the County two (2) copies of a manual, assembled, indexed, and bound, for the County's guidance, full details for care and maintenance of visible surfaces and of equipment included in Contract. Contractor shall, for this manual, obtain from Subcontractors literature of manufacturers relating to equipment, including motors; also furnish cuts, wiring diagrams, instruction sheets and other information pertaining to same that will be useful to the County in over-all operation and maintenance. Where the above-described manuals and data are called for under separate sections of the Specifications, they are to be included in the manual described in this General Requirement.

GR-35. WEATHER CONDITIONS

The Contractor will be required to protect all work and materials against damage or injury from the weather. If, in the opinion of the County, any work or materials shall have been damaged or injured by reason of failure to protect such, all such materials or work shall be removed and replaced at the expense of the Contractor.

GR-36. LINES, GRADES, AND MEASUREMENTS

- A. Such stakes and markings as the County may set for either its or the Contractor's guidance shall be preserved by the Contractor. Failure to protect such stakes or markings may, at the County's discretion, shall result in the Contractor being charged for their replacement.
- B. The Contractor must exercise proper care and caution to verify the grades and figures furnished by or on behalf of the County before proceeding with the Work, and shall be responsible for any damage or defective work caused by its failure to exercise such care and caution. Contractor shall promptly notify the County of any errors or discrepancies it may discover in order that the proper corrections may be made.
- C. Before ordering materials or doing work, the Contractor shall measure and verify the dimensions and locations of all existing structures, substrata, and features that affect the Work and shall be responsible for the correctness of same. No consideration will be given any claim based on the differences between the actual dimensions and those indicated on the Drawings. Contractor shall promptly notify the County of any difference which may be found and shall obtain direction from the County before proceeding with the affected Work.

GR-37. CLEANING UP

- A. The Contractor shall at all times, keep the premises free from accumulation of waste materials or rubbish caused by Contractor's employees or work. Upon completion of the Work, the Contractor shall remove all his plants, tools, materials, and other articles from the property of the County.

- B. If the Contractor fails to clean up, as provided in the Contract, the County may do so, and the cost thereof shall be charged to the Contractor. Contractor shall ensure that neither it, its Subcontractors, nor their employees or agents bring any hazardous materials or other materials/waste regulated by state, federal or local law, which are not commonly used in the construction process or which are not listed in any Specifications for the Project onto the Project site without first obtaining the County's advance written approval. Contractor agrees to ensure that any hazardous materials/waste or other materials/waste regulated by state, federal or local law that Contractor, its Subcontractors or their employees or agents, bring onto or generate at the Project Site are handled in accordance with all applicable laws.
- C. The Contractor shall pay all required material disposal fees and shall dispose of all materials in accordance with all applicable laws and regulations. The Contractor shall be responsible for all costs associated with improper disposal of materials, including any clean-up costs, fines or penalties, whether levied against the Contractor or the County.
- D. In addition to removing rubbish on a periodic basis and leaving the building broom clean, the Contractor shall clean all tile and glass; replace broken glass; remove stains, paint spots, and dirt from all Work; clean and polish all plumbing fixtures and equipment; and remove all temporary protection items. To the maximum extent reasonably possible, the Contractor shall keep the interior of the building free of combustible materials as the Work progresses.
- E. The Contractor shall maintain and keep clean at all times the immediate approach to the Project site, including the roads abutting the Project site.

GR-38. BARRICADES

- A. Contractor shall provide barricades and protective barriers around excavations, so that the public is adequately warned of such hazards. Lanterns shall remain lighted from sundown to sunrise and at all other times when the labor forces are not on the job site.
- B. Delivery of construction materials and equipment shall be only to locations approved by the County.

GR-39. NO THIRD-PARTY BENEFICIARY

Except as expressly and specifically set forth herein, this Contract shall not be deemed to provide any third-party with any remedy, claim, right of action, or other right.

GR-40. SEVERABILITY

If any provision of this Contract or the application thereof to any person or circumstance shall to any extent be held invalid, then the remainder of this Contract or the application of such

provision to persons or circumstances, other than those as to which it is held invalid, shall not be affected thereby, and each provision of this Contract shall be valid and enforced to the fullest extent permitted by law.

GR-41. INTERPRETATION

The laws of the State of Georgia shall govern the construction of this Contract without regard for conflicts of laws. Should any provision of this Contract require judicial interpretation, it is agreed that the court interpreting or construing the same shall not apply a presumption that the terms hereof shall be more strictly construed against one party, by reason of the rule of construction, that a document is to be construed more strictly against the party who itself or through its agent prepared same; it being agreed that the agents of all parties have participated in the preparation hereof, and all parties have had an adequate opportunity to consult with legal counsel. In interpreting this Contract in its entirety, the printed provisions of this Contract, and any additions written or typed hereon, shall be given equal weight, and there shall be no inference by operation of law or otherwise; that any provision of this Contract shall be construed against either party hereto.

GR-42. PRIOR CONTRACTS; CONFLICT IN DOCUMENTS

The Contractor may in no case claim a waiver of any specification requirements on the basis of previous approval of material or workmanship on other jobs of like nature or on the basis of what might be considered "standard" for material or workmanship in any particular location. The Contract for this Project shall govern the Work. If any portion of the Contract shall be in conflict with any other portion, the various documents comprising the Contract shall govern in the following order of precedence: Contract, Change Orders or modifications issued after execution of the Contract; the General Requirements of the Contract; the Specifications; the Drawings, as between schedules and information given on the Drawings, the schedules shall govern; as between figures given on Drawings and the scaled measurements, the figures shall govern; as between large-scale Drawings and small-scale Drawings, the larger scale shall govern; and detailed Drawings shall govern over general Drawings; and the Bid Document Package.

GR-43. ENTIRE AGREEMENT

This Contract constitutes the sole contract between the County and the Contractor. The terms, conditions, and requirements of this Contract may not be modified, except by Change Order or Field Order. No verbal agreement or conversation with any officer, agent, or employee of the County, either before or after the execution of the Contract, shall affect or modify any of the terms or obligations herein contained. No representations, oral or written, shall be binding on the parties unless expressly incorporated herein. No Change Order or Field Order shall be enforceable unless approved by official action of the County as provided by law or in this Contract.

GR-44. COUNTERPARTS

This Contract may be executed in several counterparts, each of which shall be deemed an original, and all such counterparts together shall constitute one and the same Contract.

GR-45. VENUE

The courts of DeKalb County, Georgia shall have exclusive jurisdiction to try disputes arising under or by virtue of this Contract.

GR-46. RIGHT TO AUDIT

The County shall have the right to audit all books and records, including electronic records, relating or pertaining to this contract or agreement, including but not limited to all financial and performance related records, property, and equipment purchased in whole or in part with County funds and any documents or materials which support those records, kept under the control of the Contractor, including but not limited to those kept by the Contractor's employees, agents, assigns, successors and subcontractors. The County also has the right to communicate with Contractor's employees related to the audited records.

The Contractor shall maintain such books and records, together with such supporting or underlying documents and materials, for the duration of this contract and for seven (7) years after termination or expiration, including any and all renewals thereof. The books and records, together with supporting documents and materials shall be made available, upon request to the County or its designee, during normal business hours at the Contractor's office or place of business. In the event that no such location is available, then the books, records, and supporting documents shall be made available for audit at a time and location which is convenient for the County.

ATTACHMENT B
BIDDER'S UNIT PRICE FORM

ATTACHMENT C

CONTRACTOR AFFIDAVIT UNDER O.C.G.A. §13-10-91

ATTACHMENT D

SUBCONTRACTOR AFFIDAVIT UNDER O.C.G.A. § 13-10-91

ATTACHMENT E

SUB-SUBCONTRACTOR AFFIDAVIT UNDER O.C.G.A. § 13-10-91

ATTACHMENT F

DEKALB COUNTY, GEORGIA

CERTIFICATE OF AUTHORITY - JOINT VENTURE

(Separate Certificate to be submitted by each joint venture partner)

ATTACHMENT G

(Consisting of 3 pages)

PERFORMANCE BOND

KNOW ALL MEN BY THESE PRESENTS that _____
[Insert name of contractor] (hereinafter called the “Principal”) and
_____ [Insert name of surety] (hereinafter called the “Surety”), are held
and firmly bound unto _____ County (hereinafter called the “County”) and their
successors and assigns, in the penal sum of XXXXXXXXXXXX Dollars (\$XXXXXXXXXX), lawful
money of the United States of America, for the payment of which the Principal and the Surety bind
themselves, their administrators, executors, successors, and assigns, jointly and severally, firmly
by these presents.

WHEREAS, the Principal has entered, or is about to enter, into a certain written contract
with the County, awarded by the DeKalb County Governing Authority on _____,
which is incorporated herein by reference in its entirety (hereinafter called the “Contract”), for the
Scott Candler Water Treatment Plant-Ozone Generators Design and Installation, more
particularly described in the Contract (hereinafter called the “Project”); and

NOW, THEREFORE, the conditions of this obligation are as follows, that if the Principal
shall fully and completely perform all the undertakings, covenants, terms, conditions, warranties,
and guarantees contained in the Contract, including all change orders, modifications, amendments,
changes, deletions, additions, and alterations thereto that may hereafter be made, then this
obligation shall be void; otherwise, it shall remain in full force and effect.

Whenever the Principal shall be, and declared by the County to be, in default under the
Contract, the Surety shall promptly remedy the default as follows:

1. Complete the Contract in accordance with the terms and conditions; or
2. Obtain a Bid or Bids for completing the Contract in accordance with its terms and
conditions, and upon determination by the Surety and the County of the lowest
responsible bidder, arrange for a contract between such bidder and County and
make available as the work progresses (even though there should be a default or
succession of defaults under the Contract or contracts of completion arranged under
this paragraph) sufficient funds to pay the cost of completion less the balance of the
contract price; but not exceeding, including other costs and damages for which the
Surety may be liable hereunder, the penal sum set forth in the first paragraph hereof,
as may be adjusted, and the Surety shall make available and pay to the County the
funds required by this Paragraph prior to the payment of the County of the balance
of the contract price, or any portion thereof. The term “balance of the contract
price,” as used in this paragraph, shall mean the total amount payable by the County
to the Contractor under the Contract, and any amendments thereto, less the amount
paid by the County to the Contractor; or, at the option of the County; or

- 3. Allow County to complete the work and reimburse the County for all reasonable costs incurred in completing the work.

In addition to performing as required in the above paragraphs, the Surety shall indemnify and hold harmless the County from any and all losses, liability and damages, claims, judgments, liens, costs, and fees of every description, including reasonable attorney’s fees, litigation costs and expert witness fees, which the County may incur, sustain, or suffer by reason of the failure or default on the part of the Principal in the performance of any or all of the terms, provisions, and requirements of the Contract, including any and all amendments and modifications thereto, or incurred by the County in making good any such failure to performance on the part of the Principal.

The Surety shall commence performance of its obligations and undertakings under this Bond promptly and without delay, after written notice from the County to the Surety.

The Surety hereby waives notice of any and all modifications, omissions, additions, changes, alterations, extensions of time, changes in payment terms, and any other amendments in or about the Contract, and agrees that the obligations undertaken by this bond shall not be impaired in any manner by reason of any such modifications, omissions, additions, changes, alterations, extensions of time, change in payment terms, and amendments.

The Surety hereby agrees that this Bond shall be deemed amended automatically and immediately, without formal or separate amendments hereto, upon any amendment to the Contract, so as to bind the Principal and Surety to the full and faithful performance of the Contract as so amended or modified, and so as to increase the penal sum to the adjusted Contract Price of the Contract.

The Surety’s obligations under this bond include all of the Contractor’s duties under the Contract, including without limitation its maintenance and guarantee obligations.

No right of action shall accrue on this bond to or for the use of any person, entity, or corporation other than the County and any other obligee named herein, or their executors, administrators, successors or assigns.

This Bond is intended to comply with O.C.G.A. §36-91-70 and shall be interpreted so as to comply with the minimum requirements thereof. However, in the event the express language of this Bond extends protection to the County beyond that contemplated by O.C.G.A. §36-91-70, or any other statutory law applicable to this Project, then the additional protection shall be enforced in favor of the County, whether or not such protection is found in the applicable statutes.

If any one or more of the provisions of this Bond are determined to be illegal or unenforceable by a court of competent jurisdiction, all other provisions shall remain effective.

IN WITNESS WHEREOF the undersigned have caused this instrument to be executed and their respective corporate seals to be affixed and attested by their duly authorized representatives this

day of _____, 20__.

PRINCIPAL

By: _____ (SEAL)

Signature of Principal

Print Name and Title of Authorized Signer

Print Name of Principal Business

ATTEST:

Corporate Secretary

SURETY

By: _____ (SEAL)
Signature of Surety (by Power of Attorney)

Print Name and Title of Authorized Signer

Print Name of Surety Business

WITNESS:

[Attach Original Power of Attorney]

ATTACHMENT H
(Consisting of 2 pages)
PAYMENT BOND

KNOW ALL MEN BY THESE PRESENTS that _____ *[Insert name of contractor]* (hereinafter called the “Principal”) and _____ *[Insert name of surety]* (hereinafter called the “Surety”), are held and firmly bound unto _____ County, (hereinafter called the “County”), its successors and assigns as obligee, in the penal sum of XXXXXXXX Dollars (\$XXXXXXXX), lawful money of the United States of America, for the payment of which the Principal and the Surety bind themselves, their administrators, executors, successors, and assigns, jointly and severally, firmly by these presents.

WHEREAS, the Principal has entered, or is about to enter, into a certain written contract with the County, awarded by the DeKalb County Governing Authority on XXXXXXXXXX [insert date of award] which is incorporated herein by reference in its entirety (hereinafter called the “Contract”), for the construction of a project known as **Scott Candler Water Treatment Plant-Ozone Generators Design and Installation**, as more particularly described in the Contract (hereinafter called the “Project”);

NOW, THEREFORE, the condition of this obligation is such that if the Principal shall promptly make payment to all persons working on or supplying labor or materials under the Contract, and any amendments thereto, with regard to labor or materials furnished and used in the Project, and with regard to labor or materials furnished but not so used, then this obligation shall be void; but otherwise it shall remain in full force and effect.

4. A “Claimant” shall be defined herein as any Subcontractor, person, party, partnership, corporation or other entity furnishing labor, services, or materials used, or reasonably required for use, in the performance of the Contract, without regard to whether such labor, services, or materials were sold, leased, or rented, and without regard to whether such Claimant is or is not in privity of contract with the Principal or any Subcontractor performing work on the Project, including, but not limited to, the following labor, services, or materials: water, gas, power, light, heat, oil, gasoline, telephone service, or rental of equipment directly applicable to the Contract.
5. In the event a Claimant files a claim against the County, or the property of the County, and the Principal fails or refuses to satisfy or discharge it promptly, the Surety shall satisfy or discharge the claim promptly upon written notice from the County, either by bond or as otherwise provided in the Contract.
6. The Surety hereby waives notice of any and all modifications, omissions, additions, changes, alterations, extensions of time, changes in payment terms, and any other amendments in or about the Contract and agrees that the obligations undertaken by this bond shall not be impaired in any manner by reason of any such modifications, omissions, additions, changes, alternations, extensions of time, changes in payment terms, and amendments.
7. The Surety hereby agrees that this Bond shall be deemed amended automatically and immediately, without formal or separate amendments hereto, upon any amendment or modification to the Contract, so as to bind the Principal and Surety, jointly and severally, to the full payment of any Claimant under the Contract, as amended or modified, provided only that the Surety shall not be liable for more than the penal sum of the Bond, as specified in the first paragraph hereof.

8. This Bond is made for the use and benefit of all persons, firms, and corporations who or which may furnish any materials or perform any labor for or on account of the construction to be performed or supplied under the Contract, and any amendments thereto, and they and each of them may sue hereon.
9. No action may be maintained on this Bond after one (1) year from the date the last services, labor, or materials were provided under the Contract by the Claimant prosecuting said action.
10. This Bond is intended to comply with O.C.G.A. §36-91-90 and shall be interpreted so as to comply with the minimum requirements thereof. However, in the event the express language of this Bond extends protection to the County beyond that contemplated by O.C.G.A. §36-91-90, or any other statutory law applicable to this Project, then the additional protection shall be enforced in favor of the County, whether or not such protection is found in the applicable statutes.

IN WITNESS WHEREOF, the Principal and Surety have hereunto affixed their corporate seals and caused this obligation to be signed by their duly authorized representatives this ____ day of _____, 20__.

PRINCIPAL

By: _____ (SEAL)
Signature of Principal

Print Name and Title of Authorized Signer

Print Name of Principal Business

ATTEST:

Corporate Secretary

SURETY

By: _____ (SEAL)
Signature of Surety (by Power of Attorney)

Print Name and Title of Authorized Signer

Print Name of Surety Business

WITNESS:

[Attach Original Power of Attorney]

ATTACHMENT I

**INSURANCE POLICIES WITH DECLARATIONS AND
ENDORSEMENTS**

ATTACHMENT J

EXECUTIVE ORDER NO. 2141-4 NEW ETHICS POLICY

ATTACHMENT K

OCIP GENERAL LIABILITY WRAP-UP MANUL

ATTACHMENT L

LICENSE (s) and/or CERTIFICATIONS

EXHIBIT 1

TECHNICAL SPECIFICATIONS

for

SCOTT CANDLER WATER TREATMENT PLANT - OZONE GENERATORS DESIGN AND INSTALLATION

**DeKalb County, Georgia
Department of Watershed Management
4572 Memorial Drive
Decatur, Georgia 30032**

**Technical Specifications are included on the DeKalb County Website
<https://www.dekalbcountyga.gov/purchasing-contracting/about-purchasing-and-contracting>
as an attached separate document**

EXHIBIT 2

**SPECIFICATIONS AND FUNCTIONAL DESIGN OF THE EXISTING
GENERATORS AND FACILITIES**

SPECIFICATIONS

ITEM	UNITS	PDO-12000
QUANTITY		3
CAPACITY	ppd	2000 @ 10%
CONFIGURATION: ORIENTATION: ARRANGEMENT:		HORIZONTAL DOUBLE ENDED
FEED GAS SOURCE	LOX/GOX	OXYGEN
FEED GAS QUALITY <i>(filter through 0.1 μm)</i>	% O2 by vol. ppm N ₂ ppm H ₂ O ppm hydrocarbons	93% min.; 99.5% max. > 5000 < 4 < 20
FEED GAS – FLOW RATE	scfm @ ppd O3 produced	168 @ 2000 ppd @ 10%
FEED GAS – INLET TEMPERATURE	min./max. °F	40/80
FEED GAS – INLET PRESSURE,	psig	60 max. 25 min.
FEED GAS – DEWPOINT	max. °F	-80
OZONE GAS MIXTURE – OUTLET TEMPERATURE	max. °F	120
OZONE GAS MIXTURE – OUTLET PRESSURE	psig	15 design 10 min. 20 max.
OZONE GENERATOR GAS – OPERATING PRESSURE	psig	25 max
COOLING WATER QUALITY <i>(filter through 80 μm)</i>		Rust free Oil free < 0.3 ppm Fe as Fe < 0.05 ppm Mn as Mn 6.8 – 7.4 pH < 500 ppm TDS <100 ppm Cl as Cl Non-scaling Non-corrosive Non-fouling (biological)
COOLING WATER – INLET TEMPERATURE	°F (min/max)	41 / 86 (system designed for 80)
COOLING WATER – ΔT	°F	7.5
COOLING WATER – INLET PRESSURE	psig	35 max
COOLING WATER – FLOW RATE	gpm	300
ESTIMATED POWER:		480VAC/3ph/60hz
INSTALLED BREAKER SIZE	Amps	850
NOMINAL OPERATING	kWh/lb O3 produced	4.5 @ 10% by wt.
DESIGN REQUIREMENTS:		
VESSEL CONTROL PANEL		AWS D1.1 NEMA 12

ITEM	UNITS	PDO-12000
MATERIALS OF CONSTRUCTION: VESSEL VESSEL HEAD GASKETS SHELL-WATER SIDE SHELL-SUPPORTS OXYGEN PIPING VESSEL - WATER PIPING PSU - WATER PIPING PIPE GASKETS		316L SS HYPALON 316L SS 316L SS 316L SS 316L SS COPPER TEFLON
CONNECTIONS: OXYGEN INLET OZONE OUTLET WATER INLET WATER OUTLET	inches inches inches inches	4" Class 150 RF Flange 4" Class 150 RF Flange 6" Class 150 RF Flange 6" Class 150 RF Flange
SHELL SKID SHIPPING WEIGHT	lbs.	25,000 lbs.
SHELL SKID OPERATING WEIGHT	lbs.	30,000 lbs.
PSU SKID SHIPPING WEIGHT	lbs.	25,000 lbs.
PSU SKID OPERATING WEIGHT	lbs.	25,000 lbs.
SPECIAL DESIGN CONSIDERATIONS/ REQUIREMENTS:	UNIT INSTALLED INDOORS IN A CONTROLLED ENVIRONMENT.	

GAS FLOWMETER CORRECTION

The gas flowmeter for this project is a mass flow meter, which does not require a temperature or pressure correction factor when operated within the design temperature and pressure criteria.

OZONE GENERATOR PERFORMANCE CALCULATION

Determining the ozone production of the ozone generator is a calculated value based upon the gas flow rate and the product ozone concentration. Ozone production rate is calculated as follows:

ACTUAL PRODUCTION:

$$PPD = \frac{SCFM \times \%O_3 \times 1440 \times \rho}{100}$$

SPECIFIED GAS FLOW RATE	250 SCFM
RATED GAS FLOW RATE	250 SCFM
GAS HOURLY SPACE NUMBER	3000 1/HR
CALCULATED BED VOLUME	5.0 FT3
CATALYST DENSITY	52.5 LB/FT3
CALCULATED CATALYST WEIGHT	263 LBS
BED DEPTH	1.50 FT
CALCULATED FACE AREA	3.33 FT2
CALCULATED BED DIA	2.06 FT
CALCULATED BED DIA	24.72 IN
SELECTED BED DIA	27.00 IN
ACTUAL FACE AREA	3.98 FT2
CALCULATED FACE VELOCITY	1.05 FT/SEC
CALCULATED BED CONTACT	1.43 SEC
CALCULATED D/P-1/8 EXTRUDED	1.88 IN. W.C.
GAS TEMPERATURE RISE	60 DEG F
CAPACITY	

DEKALB COUNTY
SCOTT CANDLER WATER FILTER PLANT

PCI-WEDECO JOB No. 21701

INTERMEDIATE OZONE DESTRUCTOR CALCULATIONS

SPECIFIED GAS FLOW RATE	300 SCFM
RATED GAS FLOW RATE	300 SCFM
GAS HOURLY SPACE NUMBER	3000 1/HR
CALCULATED BED VOLUME	6.0 FT3
CATALYST DENSITY	52.5 LB/FT3
CALCULATED CATALYST WEIGHT	315 LBS
BED DEPTH	1.50 FT
CALCULATED FACE AREA	4.00 FT2
CALCULATED BED DIA	2.26 FT
CALCULATED BED DIA	27.08 IN
SELECTED BED DIA	27.00 IN
ACTUAL FACE AREA	3.98 FT2
CALCULATED FACE VELOCITY	1.26 FT/SEC
CALCULATED BED CONTACT	1.19 SEC
CALCULATED D/P-1/8 EXTRUDED	2.68 IN. W.C.
GAS TEMPERATURE RISE	60 DEG F
CALCULATED HEATER CAPACITY	6.4 KW
INSTALLED HEATER CAPACITY	6.5 KW
OUTLET OZONE-MAX	0.05 PPMV

LOX EQUIPMENT

The oxygen feed for the ozone system is from either of the two Liquid Oxygen Storage Tanks (LOX Tanks). The tank level and pressure are continuously monitored by a level transmitter (LIT-4005-1, -2) and a pressure transmitter (PIT-4005-1, -2) and their signals are sent to SCADA via OSCP PLC NO.3.

From the LOX Tanks the liquid oxygen (LOX) flows under pressure to either of three Vaporizers, where it is heated (boiled) from the heat of ambient air and converted to gaseous oxygen (GOX) before entering the common GOX pipe. The heat transfer media in the fin-and-tube vaporizer is from the ambient air. As the air contacts the vaporizer fins it transfers heat thru the tubes to the LOX, which is then vaporized into GOX. Vaporizer sequence, operating, defrosting, and standby, is controlled via the OSCP.

Oxygen Equipment data summary is as follows:

LOX Tanks

Manufacturer: Chart Industries
Type: Horizontal
Model: H-13000-B-175
Number: 2
Tag No.: LOX-TK-1, LOX-TK-2
Capacity: 13,000 Gallons
Operating Pressure: 75 psig
System Operation: 1 for 100%, 1 standby
P&ID 1900-21701-PID1

Vaporizers

Manufacturer: Thermax
Type: Ambient
Model: TF3618HF-SG
Number: 3
Tag No.: VAP-1, VAP-2, VAP-3
Capacity: 34,000 scfh
Operating Pressure: 75 psig
System Operation: 1 for 100%, 1 defrost, 1 standby
P&ID 1900-21701-PID2

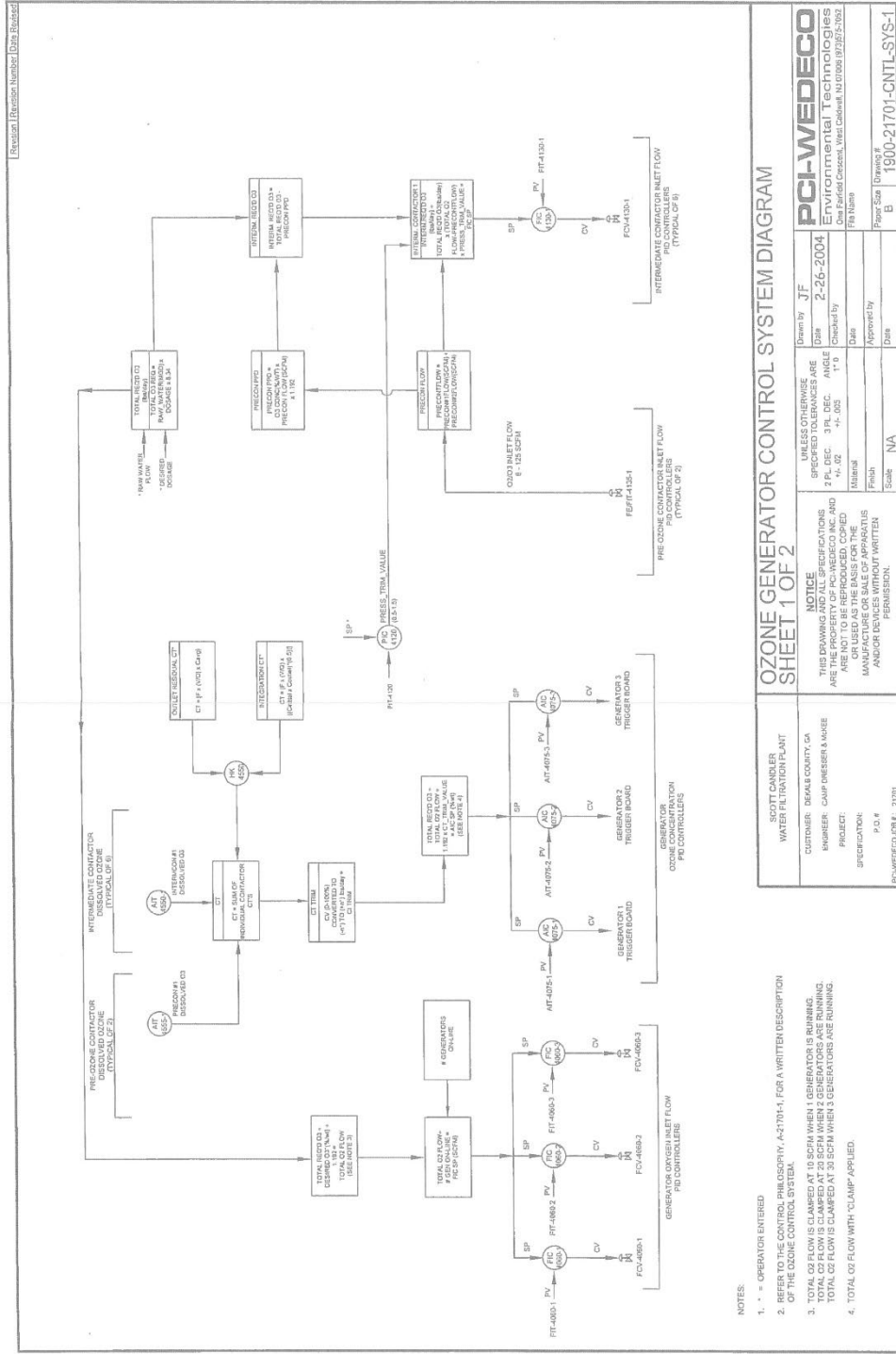

- NOTES:**
1. * = OPERATOR ENTERED
 2. REFER TO THE CONTROL PANEL ASSOCIATED WITH EACH GENERATOR FOR A WRITTEN DESCRIPTION OF THE OZONE CONTROL SYSTEM.
 3. TOTAL OZ FLOW IS CLAMPED AT 20 SCFM WHEN 1 GENERATOR IS RUNNING.
 TOTAL OZ FLOW IS CLAMPED AT 30 SCFM WHEN 2 GENERATORS ARE RUNNING.
 TOTAL OZ FLOW IS CLAMPED AT 40 SCFM WHEN 3 GENERATORS ARE RUNNING.
 4. TOTAL OZ FLOW WITH 'CLAMP' APPLIED.

**OZONE GENERATOR CONTROL SYSTEM DIAGRAM
 SHEET 1 OF 2**

<p style="text-align: center;">SCOTT CANDLER WATER FILTRATION PLANT</p> <p>CUSTOMER: DEALE COUNTY, GA ENGINEER: CAMP PRESSER & WARE PROJECT: OZONE GENERATOR INSTALLATION SPECIFICATION: P.O. # 1900-21701-CNTL-SYS-1 PCI-WEDECOR # : 2101</p>	<p style="text-align: center;">PCI-WEDECOR Environmental Technologies 10000 Gwyneth Road, Suite 100 Atlanta, GA 30328 (404) 525-1500 Fax: (404) 525-1501 www.pcidecor.com</p> <p>Drawn by: JF Date: 2-26-2004 Check by: [blank] Date: [blank] Approved by: [blank] Date: [blank] Project Size: B Drawing #: 1900-21701-CNTL-SYS-1</p>
--	---

NOTICE: UNLESS OTHERWISE SPECIFIED TOLERANCES ARE:
 FRACTIONS: 1/32" MIN.
 DECIMALS: .005"
 ANGLES: 30° MIN.
 DIMENSIONS: AS SHOWN.
 THIS DRAWING AND ALL SPECIFICATIONS ARE THE PROPERTY OF PCI-WEDECOR, INC. AND ARE NOT TO BE REPRODUCED, COPIED, MANIPULATED, OR SALE OF APPARATUS AND/OR DEVICES WITHOUT WRITTEN PERMISSION.

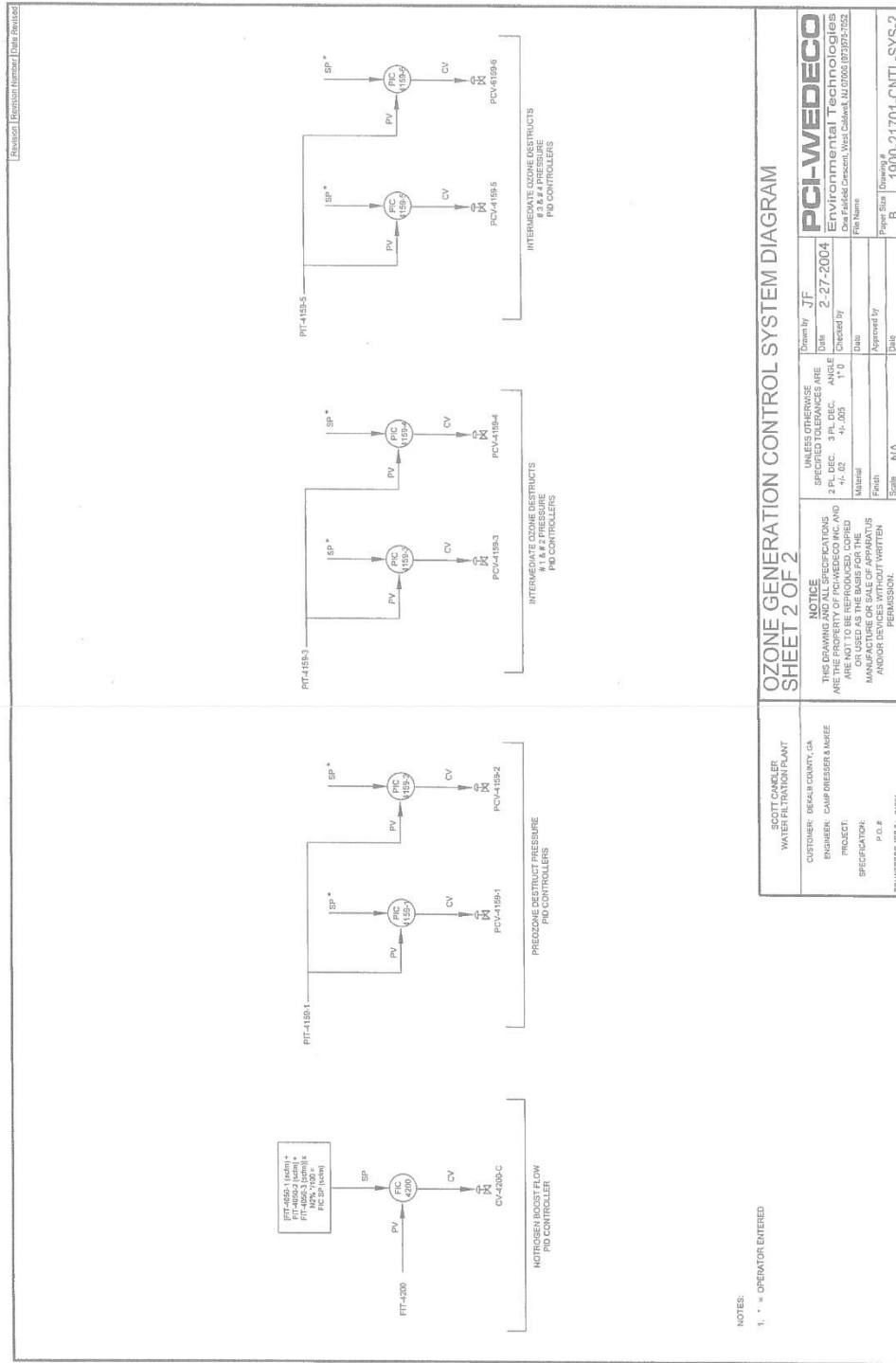

Revision: Revision Number: Date: Revoked:

SCOTT CANDLER WATER FILTRATION PLANT		NOISE	
CUSTOMER: DEKALB COUNTY, GA	ENGINEER: COMPRESSOR & MORE	UNLESS OTHERWISE SPECIFIED TOLERANCES ARE:	Drawn by: JF
PROJECT: OZONE GENERATORS	SPECIFICATION: P.O.#	± 0.125	Date: 2-27-2004
PROJECT: OZONE GENERATORS	SPECIFICATION: P.O.#	± 0.125	Checked by:
PROJECT: OZONE GENERATORS	SPECIFICATION: P.O.#	± 0.125	Date:
PROJECT: OZONE GENERATORS	SPECIFICATION: P.O.#	± 0.125	Approved by:
PROJECT: OZONE GENERATORS	SPECIFICATION: P.O.#	± 0.125	Date:
PROJECT: OZONE GENERATORS	SPECIFICATION: P.O.#	± 0.125	Scale: N/A
PROJECT: OZONE GENERATORS	SPECIFICATION: P.O.#	± 0.125	Sheet: 2 of 2
PROJECT: OZONE GENERATORS	SPECIFICATION: P.O.#	± 0.125	Page Size: B
PROJECT: OZONE GENERATORS	SPECIFICATION: P.O.#	± 0.125	Drawing #: 1010-21701-CNT1 -SYS-2

**OZONE GENERATION CONTROL SYSTEM DIAGRAM
 SHEET 2 OF 2**

PCI-WEDECO
 Environmental Technologies
 One Fairfield Center, West Caldwell, NJ 07060 (973) 515-1152
 Fax: (973) 515-1153
 E-mail: sales@pci-we deco.com
 Website: www.pci-we deco.com

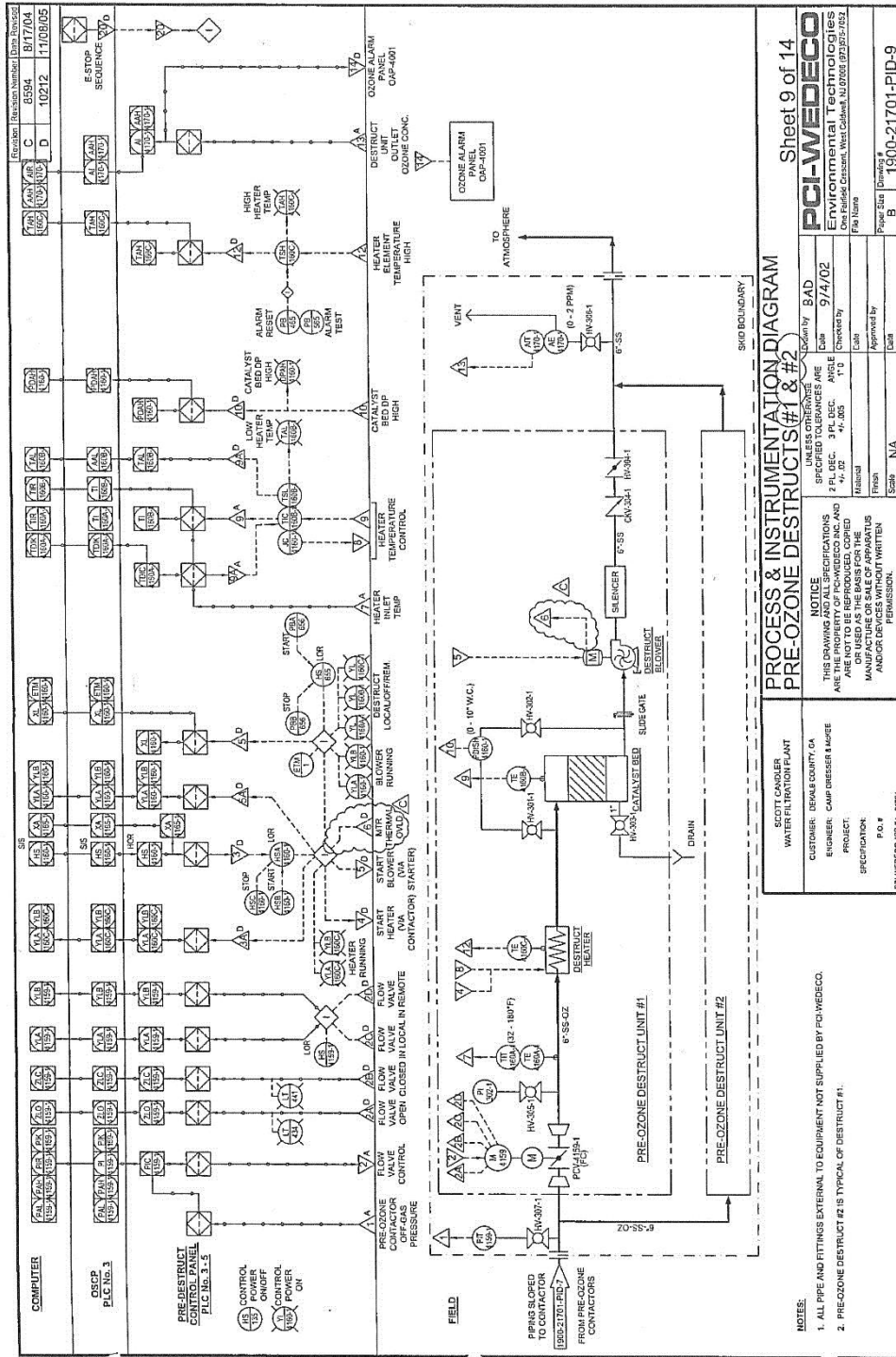

Sheet 9 of 14

PCI-WEDECO
 Environmental Technologies
 One Federal Center, West Columbia, SC 29169 (803) 792-2152

UNLESS OTHERWISE SPECIFIED BY BAD
 DATE 9/14/02
 CHECKED BY [Signature]
 DRAWN BY [Signature]
 APPROVED BY [Signature]
 DATE [Date]

NOTICE: THESE DRAWINGS SPECIFICATIONS ARE THE PROPERTY OF PCI-WEDECO INC. AND ARE NOT TO BE REPRODUCED, COPIED, OR TRANSMITTED IN ANY FORM OR BY ANY MEANS, WITHOUT THE WRITTEN PERMISSION OF PCI-WEDECO INC.

THIS DRAWING IS THE PROPERTY OF PCI-WEDECO INC. AND IS NOT TO BE REPRODUCED, COPIED, OR TRANSMITTED IN ANY FORM OR BY ANY MEANS, WITHOUT THE WRITTEN PERMISSION OF PCI-WEDECO INC.

UNLESS OTHERWISE SPECIFIED BY BAD
 DATE 9/14/02
 CHECKED BY [Signature]
 DRAWN BY [Signature]
 APPROVED BY [Signature]
 DATE [Date]

SCOTT CANDLER WATER FILTRATION PLANT
 CUSTOMER: DEWAL COUNTY, CA
 ENGINEER: CAMP DRESSER & MORSE
 PROJECT: [Project Name]
 SPECIFICATION: [Specification]
 P.O. # [P.O. Number]
 PCI-WEDECO JOB # 2701

1. ALL PIPE AND FITTINGS EXTERNAL TO EQUIPMENT NOT SUPPLIED BY PCI-WEDECO.
 2. PRE-OZONE DESTRUCT #2 IS TYPICAL OF DESTRUCT #1.

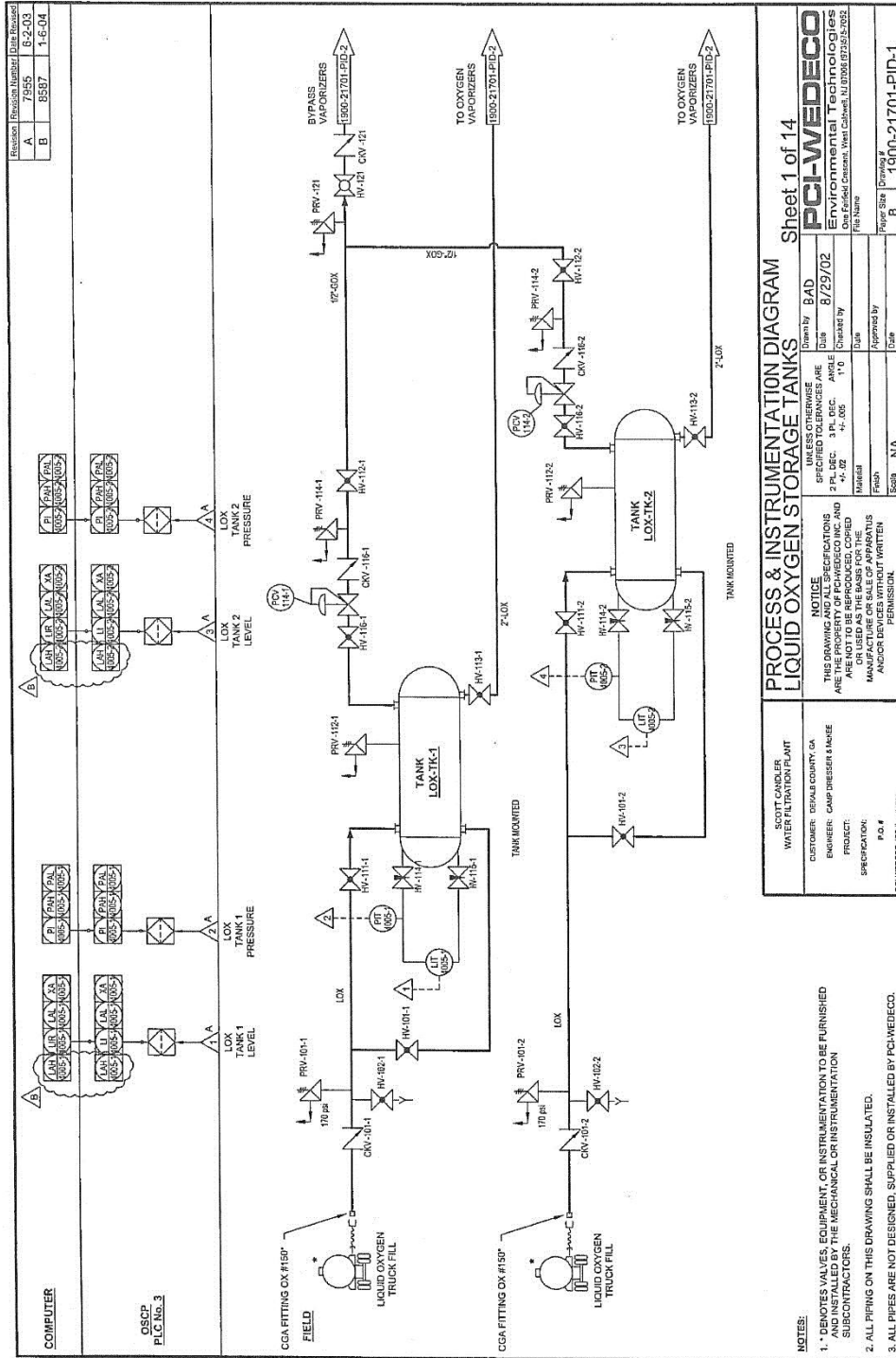

PROCESS & INSTRUMENTATION DIAGRAM
LIQUID OXYGEN STORAGE TANKS
 Sheet 1 of 14

SCOTT CANDLER WATER FILTRATION PLANT CUSTOMER: DEKALB COUNTY, GA ENGINEER: CAMP PREESE & MOSE PROJECT: SPECIFICATION: P.O. #	UNLESS OTHERWISE SPECIFIED TOLERANCES ARE: 2 P.L. DEC. 3 P.L. DEC. 4 P.L. DEC. 5 P.L. DEC. +/- .02 +/-.005 +/-.01	Dimension by: BAD Date: 8/29/02 Checked by: J.F. Drawn by: J.F. Title: Ozone Generator 1/16 Scale Revision: Author: J.F. Date: Project: Drawing #: Sheet: Scale: NA
--	---	---

NOTES:
 1. * DENOTES VALVES, EQUIPMENT, OR INSTRUMENTATION TO BE FURNISHED AND INSTALLED BY THE MECHANICAL OR INSTRUMENTATION SUBCONTRACTORS.
 2. ALL PIPING ON THIS DRAWING SHALL BE INSULATED.
 3. ALL PIPES ARE NOT DESIGNED, SUPPLIED OR INSTALLED BY PCI-WEDECO.

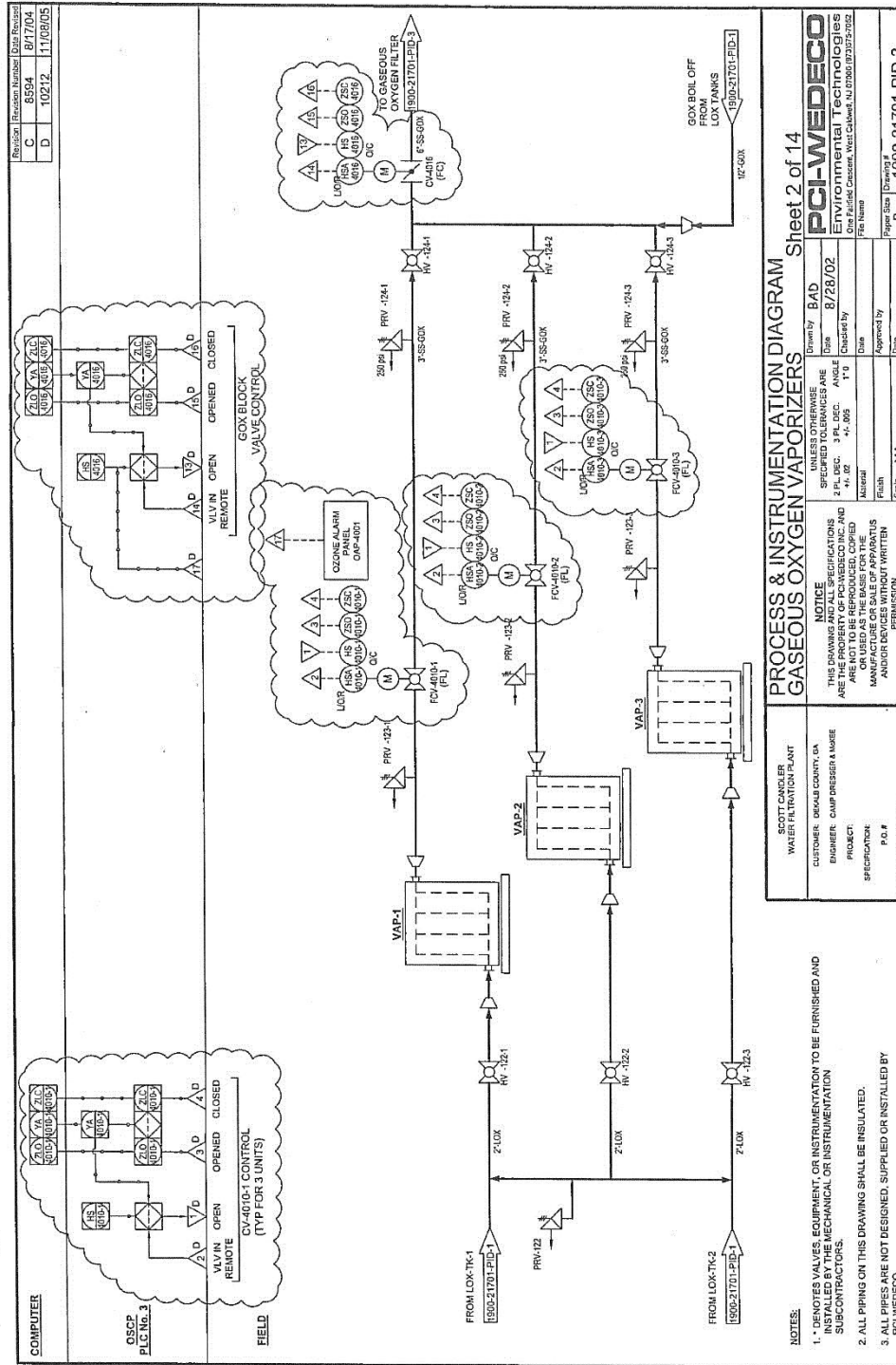

Revision	Revision Number	Date	Revised
C	8504	8/17/04	
D	10212	11/09/05	

PROCESS & INSTRUMENTATION DIAGRAM
GASEOUS OXYGEN VAPORIZERS

Drawn by: BAD
 Date: 8/28/02
 Checked by: T. P.
 Date: 4-1-05
 Approved by: [Signature]
 Date: [Date]

Scale: N/A

Project: 1000 04701.DIN.2

NOTICE
 UNLESS OTHERWISE SPECIFIED, ALL DIMENSIONS ARE IN INCHES. DIMENSIONS IN PARENTHESES ARE FOR INFORMATION ONLY AND ARE NOT TO BE REPRODUCED COPIES AND OR USED AS THE BASIS FOR THE MANUFACTURE OR SALE OF APPARATUS AND/OR INSTRUMENTATION.
 ALL DIMENSIONS ARE AS SHOWN UNLESS OTHERWISE SPECIFIED.
 ALL DIMENSIONS ARE TO CENTER UNLESS OTHERWISE SPECIFIED.
 ALL DIMENSIONS ARE TO FACE UNLESS OTHERWISE SPECIFIED.
 ALL DIMENSIONS ARE TO CENTER UNLESS OTHERWISE SPECIFIED.
 ALL DIMENSIONS ARE TO FACE UNLESS OTHERWISE SPECIFIED.
 ALL DIMENSIONS ARE TO CENTER UNLESS OTHERWISE SPECIFIED.
 ALL DIMENSIONS ARE TO FACE UNLESS OTHERWISE SPECIFIED.

NOTES:
 1. * DENOTES VALVES, EQUIPMENT, OR INSTRUMENTATION TO BE FURNISHED AND INSTALLED BY THE MECHANICAL OR INSTRUMENTATION SUBCONTRACTORS.
 2. ALL PIPING ON THIS DRAWING SHALL BE INSULATED.
 3. ALL PIPES ARE NOT DESIGNED, SUPPLIED OR INSTALLED BY PCI-WEDECO.

EXHIBIT 3

CONTRACTUAL STANDARDS and REGULATIONS

**DeKalb County Department of Watershed Management
 4572 Memorial Drive
 Decatur, Georgia 30032**

All materials and equipment shall be new and of the standard and quality specified.

The Contractor shall ensure that they are fully acquainted with the contents of the applicable Electrical Specifications.

All wiring installations shall comply fully with NEMA WC5 and UL 83 as amended.

The design and manufacture of equipment and the complete installation shall be carried out and tested in accordance with the latest issue or amendments of the following Regulations, as applicable:

Contractor must comply with all Local, State and Federal Regulations including, but not limited to, the following Specifications and Standards:

Item	Title	Edition
1	Department of Watershed Management Design Standards, Potable Water Main, Gravity Sanitary Sewer, and Sanitary Sewer and Force Main Design Standards	2017 Edition <i>Or Latest Edition</i>
2	Georgia Environmental Protection Division Minimum Standards for Public Water Systems	Latest Edition
3	Codes adopted and enforced by DeKalb County: <ul style="list-style-type: none"> o International Building Code, 2012 Edition, with Georgia Amendments o International Mechanical Code, 2012 Edition, with Georgia Amendments o International Plumbing Code, 2012 Edition, with Georgia Amendments o International Fire Code, 2012 Edition, with Georgia Amendments o International Energy Conservation Code, 2009 Edition, with Georgia Supplements and Amendments o NFPA National Electrical Code, 2014 Edition o 2012 NFPA 101 Life Safety Code with all Georgia State Amendments o Georgia Accessibility Code Chapter 120-3-20, as amended o 2010 Americans with Disabilities Act (ADA) Standards for Accessible Design 	As referenced or Latest Edition

Item	Title	Edition
	o Any local electrical and instrumentation and controls (I&C) codes.	
3	Technical Specifications (included)	Attached
4	ASTM International Standards formerly known as American Society for Testing and Materials (ASTM)	Latest Edition
5	American Water Works Association (AWWA)	Latest Edition
6	National Sanitation Foundation (NSF)	Latest Edition
7	American Concrete Institute (ACI)	Latest Edition
8	29 Code of Federal Regulations (CFR) 1910	Latest Edition
9	29 Code of Federal Regulation 1926	Latest Edition
10	American Gas Association (AGA)	Latest Edition
11	American National Standards Institute (ANSI) Standards: o Z535.1 - Safety Color Code	Latest Edition
12	American Society of Heating, Refrigerating and Air-Conditioning Engineers	Latest Edition
13	American Society of Mechanical Engineers (ASME)	Latest Edition
14	American Welding Society (AWS) Standards	Latest Edition
15	Compressed Gas Association (CGA) Standards	Latest Edition
16	Instrumentation, Systems, and Automation Society (ISA) Standards	Latest Edition
17	National Fire Code	
18	W. National Fire Protection Association (NFPA) Standards o Fire Prevention Code Handbook o NFPA13 - Installation of Sprinkler Systems. o NFPA30 - Flammable & Combustible Liquids Code. o NFPA54 - National Fuel Gas Code. o NFPA58 - Liquefied Petroleum Gas Code.	Latest Edition
19	National Sanitation Foundation (NSF) Standards o 61G - Drinking Water System Components – Health Effects and Lead Content o 372 - Drinking Water System Components – Lead Content.	Latest Edition
20	Occupational Safety and Health Act (OSHA)	Latest Edition

Item	Title	Edition
21	Pipe Fabrication Institute (PFI): <ul style="list-style-type: none">o ES-3 - Fabricating Tolerances.o ES-4 - Hydrostatic Testing of Fabricated Piping.o ES-24 - Pipe Bending Methods, Tolerances, Process and Material Requirements	Latest Edition
22	All pipework in accordance with the relevant ANSI and American Water Works Association (AWWA) standards as being appropriate	Latest Edition

How to Obtain the Referenced Technical Specifications:

1. Department of Watershed Management Design Standards, Potable Water Main, Gravity Sanitary Sewer, and Sanitary Sewer and Force Main Design Standards.
<https://www.dekalbcountyga.gov/watershed-management/office-engineering-construction-management-services>

This section is intentionally left blank. Section continues the following page.

EXHIBIT 4

Technical Criteria – Ozone Generators (Consisting of 24 pages)

1.0 SCOPE OF WORK

The Work comprises the design, proposal, manufacture, supply, testing, care and storage, delivery, installation and commissioning of ozone generators, valves and connecting pipework together with the new Power Supply Units (PSU), switchgear, cabling and all instrumentation and control requirements.

The specific areas of Work include, but are not limited to, the following:

- a) Design and/or proposal of suitable ozone generators to comply with the performance criteria herein and with all other relevant project requirements and data provided.
- b) Proposal of a suitable combination of ozone generators, operating in parallel, to meet the required production rates and delivery pressures. The new configuration will consist of the existing two generators with the two new generators (of equal duty) operating in parallel. On completion of this project, at any point in time, one, two, three or four generators in any configuration can be operational in parallel, at the same time.
- c) The new generators will be designed and manufactured in such a way that:
 - Each unit meets the duty of 2,000 PPD (pounds per 24-hour day – lbs/d) at an ozone concentration of a range between 3.0% and 12.0% by weight;
 - The units use liquid oxygen gas as the source for the ozone;
 - The units provide harmonic mitigation evaluations and equipment with each ozone generator PSU;
 - A closed loop cooling and heat exchange system to be supplied with the new generators (therefore the existing cooling water will not be used for the new generators);
 - The generators can function independently of nitrogen being available or not;
 - The units are manufactured with durable material with no glass (quartz) components.
- d) Preparation and submission of all reports, design calculations, plans (utility, civil, mechanical, HVAC and electrical), and shop drawings to the Owner for review. The Owner's review of these designs and drawings shall not relieve the Contractor of any of his/her obligations under the Contract.
- e) Selection of corrosion protection of all equipment to the relevant standards.

- f) Confer with the Owner regarding final generator selection and the control philosophy. Approval from DWM PM is required prior to purchase of generator.
- g) Design, manufacturing, supply, assembly and the quality control requirements of generators, PSUs, valves, flow meters, pipework, civil/structural work, and electrical equipment and instrumentation.
- h) Shop testing (at full and minimum operating loads) of the new generator sets to verify the guaranteed performance.
- i) Supply and installation of instrumentation for the new generators including re-programming of the PLC required to accommodate the additional generator (from three generators to four generators). Integration of the new generator into the SCADA system is also required. This will be done in accordance with the new operating/control narrative.
- j) Insurance of all the equipment for the period of manufacture, storage, delivery and installation.
- k) Civil work to accommodate the installation of the generators, pipework, valves, cables and PSUs, including the demolishing (and making good) of concrete platforms and footings supporting the existing generator. The civil work may also include gaining access to the generator room and making pipe/cable penetrations through walls and floors.
- l) Submittals of Shop Drawings, electrical diagrams and P&IDs for all equipment, any structure, piping and cabling, and shall consist of such detailed drawings as may be required for the execution of the Work. Shop Drawings must be approved by the Owner before the related work is performed or manufacturing commences.
- m) Where work is performed that interfaces with the existing cooling water, oxygen and nitrogen supply, and ozone delivery points, the Contractor will put into place special measures to avoid any spills and contamination or debris entering any of these connection points. Under no circumstances will any activities be performed that compromises the quality of the ozone, this includes for the disinfection of the new generators and pipework before they are installed into the Plant or connected to the existing pipes.
- n) The preparation and submission of all as-built records, drawings, diagrams, operation and maintenance manuals, and standard operating procedures, and the integration thereof with the existing completion documentation, clearly indicating what is new or existing equipment,
- o) Guarantee of the equipment for a period of twenty-four (24) months after the Final Completion of all Work.
- p) Required staff training – 48 hours.

The installation of the generators shall be conducted in such manner that the existing generators remain operational throughout construction.

The Contractor shall install one generator at a time until both generators have been successfully installed. This may require the modification of the PLC and control philosophy to allow for the change over from the old to the new generators during this period. The performance of the individual generators shall be tested to the satisfaction of the Owner before commissioning; however no partial completion shall be given. **Substantial Completion** shall be given only once all the generators have been installed and commissioned successfully and have passed the Acceptance Tests.

2.0 REQUIREMENTS CRITERIA

2.1 General

This Work includes (but is not necessarily limited to) the following key tasks and responsibilities:

- a) Proposal of generator sets for stated operating performance, to include a Generator Design Review Report.
- b) PSU proposal and design.
- c) Supply/manufacture and delivery of generator sets, including supply/manufacture of PSUs, with the specified minimum power reserve.
- d) Performance Testing and verification by an accredited third party, of each individual generator set to demonstrate compliance with the full spectrum of the varying operating requirements. Testing in accordance with the operating envelope will be required at the generator supplier's factory prior to delivery, with the objective of verifying the ability of each generator to meet the required performance (ozone concentration and PPD) at the guaranteed efficiency (oxygen consumption). Refer to the relevant clause for the range of testing parameters:
 - Testing and commissioning of the combined generator sets after installation is also required to demonstrate compliance with the full range of specified outputs against the specified efficiency requirement.
 - Acceptance testing of the generators shall be performed on site after installation.
 - The guaranteed performance of the generators will neither be based or dependent on the introduction of nitrogen and will only be on the oxygen supply.
- e) Installation of all the equipment to be supplied.
- f) Maintenance of the commissioned generator sets installed (reasonable wear and tear excluded) for the duration of the warranty period.
- g) This section of the Design Criteria shall be read in conjunction with the following reference documents and technical specifications.

Reference Documents:

- American Gas Association (AGA)
- American National Standards Institute (ANSI) Standards:
 - Z535.1 - Safety Color Code
- American Society of Heating, Refrigerating and Air-Conditioning Engineers
- American Society of Mechanical Engineers (ASME)
- American Society for Testing and Materials (ASTM)
- American Welding Society (AWS) Standards
- Compressed Gas Association (CGA) Standards
- Instrumentation, Systems, and Automation Society (ISA) Standards
- National Fire Code
- W. National Fire Protection Association (NFPA) Standards:
 - Fire Prevention Code Handbook, 2012 Edition.
 - NFPA13 - Installation of Sprinkler Systems.
 - NFPA30 - Flammable & Combustible Liquids Code.
 - NFPA54 - National Fuel Gas Code.
 - NFPA58 - Liquefied Petroleum Gas Code.
- National Sanitation Foundation (NSF) Standards
 - 61G - Drinking Water System Components – Health Effects and Lead Content.
 - 372 - Drinking Water System Components – Lead Content.
- Occupational Safety and Health Act (OSHA)
- Pipe Fabrication Institute (PFI):
 - ES-3 - Fabricating Tolerances.
 - ES-4 - Hydrostatic Testing of Fabricated Piping.
 - ES-24 - Pipe Bending Methods, Tolerances, Process and Material Requirements
- All pipework in accordance with the relevant ANSI and American Water Works Association (AWWA) standards as being appropriate
- Technical Specifications: As attached herein.

- h) See Specifications and Functional Design of the Existing Generator & Facilities (Exhibit 2) for the functional design of the existing generators and facilities. Existing drawings are provided separately.
- i) The schedules contained herein summarize the conditions of service. They must be read in conjunction with all the relevant drawings, P&IDs, loop and electrical diagrams.
- j) Provision shall be made for generator sets to be equipped with sensors to monitor the generator and PSU's temperatures in accordance with the P&IDs attached in Technical Specifications (Exhibit 1). Sensors shall be equal to the existing (where appropriate) to ensure effective operation in all operating conditions, and be installed complete with all wiring, junction boxes, power supply from the PSU and integrated with the PLC/SCADA. The power supplies shall be designed with protection from temporary brownouts where inlet line voltage may vary a maximum of 10 percent of the normal line voltage.
- k) All mechanical, electrical, instrumentation and control, civil and structural designs will be stamped by Georgia PEs in accordance with the specific discipline of design work provided. The Georgia PE requirement also includes any necessary structural modifications to the existing concrete platforms, including the floor, where the new generators will be installed. In the event the new generators/PSUs have higher loads than the existing structure, structural modifications may be required. The Contractor will be responsible for reinforcing or replacing structural elements of the floor to accommodate the additional loads as required.
- l) The Contractor shall be responsible for all mechanical, electrical, instrumentation and control, civil and structural work for the project, including the integration of the various instruments and controls with the PLC/SCADA. It is expected that the Contractor will engage a number of Sub-Contractors, and it will be the Contractors responsibility to manage these resources.

2.2 Generator Requirements

The generators are installed in a potentially highly corrosive and explosive environment, especially due to high O² and O³ concentrations. The design, including all electrical and instrumentation equipment, shall be designed accordingly. All stainless-steel pipes will be cleaned (pickled) and passivated on completion of installation.

Full details (shop drawings) of the actual generators the Contractor plans to supply are to be submitted to the County for approval.

2.2.1 Generator Station Capacity, Design and Operating Philosophy

The ozone generator facility (generators and all appurtenances) shall transfer a total of 160 to 8,000 PPD of ozone by generating with one to four generators at a concentration

of up to 12% by weight. This is, however, based on the condition that the existing generators can produce 2,000 PPD each.

The generators will be fully capable of a reduced production rate (turn down ratio) from 8% to 100% (160 to 2,000 PPD each) of the full production capacity (or from Plant data).

The generator sets shall be dually controlled from within the ozone generator room and the main control room. The main control room is located in the SCWTP Administration building. It is expected that the existing instrumentation shall be suitable for monitoring and control purposes, and therefore, it will be necessary for the generator supplier to maintain the status quo with the new equipment. The new generators/PSUs will, however, be equipped with all of their own instruments as specified, and the PLCs will require additional programming to substitute the one new generator with the old generator, which will be removed, and the other new generator, which will be placed in the vacant position next to the other generators.

The operating/control philosophy shall typically be in accordance with the philosophies of the existing generators; however, this shall be confirmed with the Owner.

The following product data shall be submitted by the Contractor as part of the bid (for each item of equipment):

- a) Design features
- b) Load and input capacities
- c) Efficiency ratings
- d) Material designations by UNS alloy number and ASTM Specification and Grade
- e) Data needed to verify compliance with the Specifications
- f) Catalog data
- g) Clearly marked submittal information to show specific items, materials and accessories or options being furnished
- h) Wiring, control schematics, control logic diagrams and ladder logic or similar for computer-based controls.

2.2.2 Generator Equipment

The generators shall be designed to meet the following:

- a) One generator operating shall meet the minimum production of 2,000 PPD ozone at a concentration of 12% by weight.

- b) Notwithstanding one, two, three, or four generators being operated in parallel, at no time will a condition occur where the generators are run beyond their safe operating limits, i.e., too high temperature, not meeting the concentration, etc.
- c) The generators will fit in the allowable and available area.
- d) At full and reduced production, the new generators will:
 - Consume oxygen at an optimum level,
 - Consume power at an optimum rate.

Other design considerations are:

- a) The delivery pressure of the ozone will be fully controllable but with a minimum output pressure of 43.5 pounds per square inch gauge or the minimum required process pressure.
- b) The generators will operate efficiently at elevated cooling water temperatures of up to 95 degrees Fahrenheit (°F).
- c) The voltage required by the generator shall not exceed 480 volts.
- d) All instrumentation will be protected with at least a National Electrical Manufacturers Association (NEMA) Enclosure Type 4X. Where required to be compatible with oxygen, ozone or nitrogen environments, the enclosure type rating will be increased.
- e) Power supply enclosures shall be NEMA Type 12 steel enclosures, completely gasketed on construction seams and doors. All gaskets shall be constructed of material suitable for ozone service. Mount the enclosure on a skid fabricated from ASTM A-36 structural steel and painted appropriately. Provide lifting lugs at each corner of the enclosure to facilitate lifting.
- f) Start-up to a maximum capacity in less than two minutes.
- g) Electromagnetic compatibility (EMC) approval certification that the ozone generator has no electromagnetic fields that interferes with other products or endangers the safety of the operator.
- h) Noise levels generated by the generator set shall conform to the maximum acceptable noise level and duration as defined by OSHA, city codes and any other applicable regulatory standards (i.e. industrial hygiene), unless specified otherwise.
- i) The ozone cylinder shell shall be constructed of double butt-welded seams in accordance with ASME standards for ozone generators. Shell design corrosion allowance: 1/8 inch (minimum).

2.2.3 Factory Performance Testing of Generators and Damages

Third Party and Owner witnessed factory testing (also referred to as Factory Acceptance Tests - FAT) shall be performed in accordance with international best practice standards and the activities/parameters agreed with the Owner, as detailed in the Contractor's Performance Acceptance Tests schedule developed in the design stage of the project. The tests shall be performed at the manufacturer's premises for each individual generator at full and minimum operating conditions (MOC) and three incremental points between full and MOC, to demonstrate compliance with stated guarantees. As a minimum, the following shall be tested and presented in a report with all the data and associated graphs:

- a) Maximum ozone production (converted to lbs/d),
- b) Maximum concentration of ozone (%),
- c) Maximum oxygen consumed (converted to lbs/d) for each pound of ozone produced,
- d) Maximum nitrogen consumed (converted to lbs/d) for each pound of ozone produced, however the performance shall be guaranteed without the introduction of any nitrogen,
- e) Maximum power absorbed (kilowatt-hours [kWh]) at guaranteed ozone production rate (kWh/pound of ozone),
- f) Highest temperature observed in ozone generator (°F),
- g) Highest and lowest ozone pressures on delivery side of ozone generator (PSI), and
- h) Overall performance of generator.

Note that no negative tolerance on ozone production and concentration or positive tolerance on oxygen or power consumed at full operating conditions shall be allowed. This shall be specifically observed during the factory tests and verified by an accredited third party.

All other functional tests regarding instrumentation and controls shall also be simulated and prove to be in accordance with the functional design specifications.

Should factory tests for any of the items 'a' to 'g' above, indicate that the generator performance deviates by more than 5%, the generator will be totally rejected. If generator performance varies between 5% and the specified acceptance criteria of the test standard, the Contractor will be allowed a time of three weeks to make the necessary adjustments. Should the generator test fail again, the generators will be rejected.

The Contractor will ensure that all consumables for the Performance Test, including cooling water, are available in accordance with the concentrations, pressures and temperatures as detailed in the site conditions. Should the generator supplier be unable to perform a Performance Test at his/her factory, alternative recognized generator test

facilities in the Country of Manufacture shall be utilized, and the cost of testing, transportation of the generators, insurance, etc. shall be included in the cost for testing.

The Performance Tests shall be witnessed by three of the Owner's representatives present in the presence of the Third-Party authority.

Should the generator Acceptance Tests indicate that the generator performance falls outside of the requirements of the test standard, liquidated damages as deemed by the Owner shall be applied at \$1000/day.

Generators shall be tested in the factory for release purposes, but Acceptance Tests of the generators shall be performed on site (SCWTP). The Contractor shall ensure that adequate facilities are available on site to execute an accurate generator test.

2.2.4 Commissioning and Testing

On site commissioning and testing will be done in the following steps, after the installation of all equipment has been completed:

- a) Pre-Operation Checkout
- b) Functional Test
- c) Operational Test (10-day Test)
- d) Acceptance Test (30-day Test)

Commissioning and testing of generator sets (and appurtenant contractual mechanical & electrical works) shall be carried out to the Owner's approval. The Contractor will be required to draw up, during the design stage, a comprehensive plan, including check lists, the report format with proposed lists of data and graphs and levels of accuracy, and a program to demonstrate how and when the above tests will be conducted. The plan will include on-line measurements to demonstrate the effectiveness, efficiency and reliability of the installed system. Where it is deemed necessary, local flow rates will be measured using temporary flow meters, or samples will be taken to verify production and consumption rates and/or concentration levels, the cost of such outsourced special instrument hire and sampling being reimbursed from the contract sum.

- a) Pre-Operation Checkout

Draft versions of the O&M Manuals shall be submitted for review by the Owner's Representative thirty days (or more) in advance of the Pre-Operation Checkout.

Pre-Operation Checkout (Dry commissioning) of each individual piece of equipment may commence directly after installation provided power is available and testing operation shall not interfere with the operation of the other generators. Pre-Operation Checkout shall comprise visual inspections, inspection of corrosion protection, confirming final colours, confirm parameters of the generator, loop checks for all instrumentation cable, check and confirm alignment parameters, cycle valves, etc.

Pressure testing of all pipework and ozone generators shall be completed before the Pre-Operation Checkout and will not be deemed as completed successfully except if witnessed and signed off by the Owner.

b) Functional Test

Functional Testing (Production Commissioning) of the individual generator sets shall follow after the Pre-Operation Checkout of the individual generator sets (including appurtenant) has been duly completed. Functional Testing may extend (in aggregate) over a period of up to two weeks (not necessarily including 'down-time' to resolve problems). During Functional Testing, pipework shall be filled with oxygen, and cooling water, and generator sets shall be run for the first time, first individually, then in parallel with either one or more generator sets. All instrumentation shall be set and calibrated, alarm and emergency conditions shall be simulated (e.g., power failure, overheating, oversupplying, overpressure, etc.). This process will continue until both the generators have been tested.

c) Operational Test (15-day Test)

After successful Functional Testing, the generators shall be prepared for an Operational Test, which will last for not less than 15 days. The new generators will fully integrate with the existing generators and in various operational modes, to be agreed with the Owner.

The following scenarios will be tested for the new generators only:

- Operate a new generator at minimum production rate with one or more of the existing generators,

- Operate a new generator at full production with one or more of the existing generators,
- Operate a new generator at mid-level production rate with one or more of the existing generators, and
- Operate a new generator at variable production rate (modulating between minimum and maximum production) with one or more of the existing generators.

During this time and during all other testing periods, trending will be done on all the critical instruments of the new generators, including, but not limited to:

- Flows for the incoming oxygen,
- Flows for the incoming nitrogen (if applicable),
- Flows for the produced ozone,
- Pressures for oxygen entering the generators and ozone leaving the generators,
- Temperature of incoming oxygen and outgoing ozone,
- Temperature for incoming and outgoing cooling water, and
- Power supply (volt and amps) to the generator PSU.

The Contractor shall insure that sufficient capacity exists to store the data for this period. The data will be handed over to the Owner in the form of graphs displaying the data in relation to the set points and oxygen consumed and production levels achieved.

The Functional Testing shall be successful only if no failures occurred during the 10-day period. If any piece of the equipment or an instrument fails (or operates beyond its limits), the operations do not follow the functional design specification or leaks occur on the pipes, the tests will not be deemed as successful and the failure will be addressed and the test repeated.

d) Acceptance Test (30-day Test)

On completion of the Operational Test, the generator station shall be prepared over a period of 14 days for the Acceptance Testing. Any changes that were made during the Operational Test shall be signed off by the Owner.

The Contractor will be responsible for conducting all tests (in conjunction with the Owner) and will be required to have a licenced operator to conduct the tests. The Contractor shall also appoint and remunerate a Third-Party authority to be present during the Acceptance Test. The Contractor will provide the Owner with the credentials of three test authorities of which the Owner will select one.

On approval by the Owner, the Acceptance Test will commence and will be conducted over a period of 30 days. Various operational modes during this period will be agreed with the Owner in advance. These may be as follows, for instance:

- Keep one of the new generators running at the certain production rate for a certain period of time, with one or more of the existing generators in parallel.
- Operate one of the new generators at minimum production for a couple of hours a day with one or more of the existing generators in parallel.
- Operate one of the new generators at maximum production for a couple of hours a day with one or more of the existing generators in parallel.
- Operate one of the new generators at variable production (modulating between minimum and maximum) with one or more of the existing generators in parallel for most of the time.
- Ensure that the two new generators are rotated as duty generators to equalize their running hours.
- The above scenarios will be achieved without any of the performance criteria being exceeded or not achieved.

During this time and during all other testing periods, trending will be prepared on all the critical instruments of the new generators as described above during the Operational Test.

Acceptance Tests shall include the performance results of each generator. The results of the tests shall be evaluated by the Owner and a decision regarding the application of penalties shall be made.

Acceptance Tests for generators shall not be conducted in the manufacturer's factory or at alternative facilities but shall take place on site.

At this stage, the O&M Manuals shall have been revised to reflect the findings of successive individual generator set testing, and the complete copies with

modifications will be issued to the Owner within 7 days after completion of the tests.

Once the tests have been completed and O&M Manuals have been approved, the ozone generators shall become the responsibility of the Owner for operation. In addition, the basic definition referenced herein, complying with all the above tests and submission of the O&M Manuals will constitute **Substantial Completion**.

2.3 CRANAGE AND ACCESS

No overhead crane is available for offloading and installation purposes. Access into the ozone generator room is through a roll-up door with height restrictions. It is the responsibility of the Contractor to ensure that a suitable crane is provided for all removal and installation purposes, taking into consideration the space and load constraints as the loading area is on top of the ozone contactor tank, which will have some specific loads restrictions. It is the Contractor's responsibility to prepare all necessary calculations to ensure that these restrictions are not exceeded at any point in time taking into consideration all the various climatic and load conditions.

2.4 ELECTRO-MECHANICAL REQUIREMENTS

2.4.1 Scope

This scope covers the design, supply, delivery, installation, testing, commissioning and warranties for the PSUs and generator sets, including all appurtenances. Installation and commissioning shall occur as soon as the generators are available. Shutdowns for periods of no more than 3 hours duration are accepted but must be arranged prior with the Owner.

This scope includes, but is not necessarily limited to, the following prime tasks and responsibilities:

- a) The evaluation of existing conditions and new work plans for use in the calculation of heating, ventilation, and air conditioning (HVAC) loads to be used in design and selection of systems and equipment for upgrade or replacement.
 - i) The Contractor shall perform calculations for the upgraded generator room to determine the HVAC loads and upgrade the ventilation systems and/or provide cooling systems as necessary to allow the PSUs and controls to operate under the manufacturers' recommended conditions.
 - ii) Cooling and ventilation systems shall be designed and installed to meet the 2012 IMC and other applicable codes and requirements, per the Georgia's

Construction Code Program, including GA amendments, Energy Codes, and any local codes or requirements that may be in effect.

- b) The selection, manufacture and supply of suitable generators complete with PSUs, including generator bases (soleplates);
- c) Control instrumentation and signal cable terminating in a terminal box at the generator set;
- d) Network communications between the PSUs and SCADA network interface;
- e) All pipework and valves in accordance with the existing generator assemblies/P&IDs, to tie into the headers and tie in points allowed for;
- f) Any other installation equipment/materials stated or implied to provide for a complete installation in accordance with the Specifications, Drawings and Schedules supplied; and
- g) Commissioning after installation and supplying of O&M Manuals.

2.4.2 Equipment Supplied and Installed

No equipment shall be supplied or installed by others. The Contractor will design and supply all equipment with the following as specified by the Owner:

- a) Contractor to utilize Allen Bradley latest Compact Logix or ControlLogix PLCs with the latest Logix compatible software version at the time of implementation. (CompactLogix 5380 series w/memory module or ControlLogix 5580 series w/memory module, Studio 5000 Logix Designer software) without exception, (including all programming and with redundancy on master PLC) and into the facility's existing Factory Talk Supervisory Control and Data Acquisition (SCADA) System. All existing Siemens PLC hardware will be removed and replaced with Allen-Bradley. Communication with new equipment will use Ethernet Industrial Protocol (IP) where available

2.4.3 General Information

- a) This section shall be read in conjunction with the Technical Specifications.
- b) Only equipment based on proven technology and of high reliability shall be considered for use.
- c) All items referenced shall be completed in full and submitted with the Bid. The following shall be submitted but not limited to:
 - Data curves showing how power consumption (kwh/lbs.) varies with varying ozone production rates. The curves shall cover an ozone

production range from 8 to 100 percent of its maximum ozone production capacity of 2000 PPD, at ozone concentrations of 6%, 8%, 10%, and 12% by weight.

- Preliminary dimensional drawings including installation drawings and details.
 - Design data for the ozone generator and power supply.
 - Manufacturer and model number for each component, size, type, material of construction, weight, capacity, pressure rating and location of pressure and temperature gauges, flow meters, relief valves, etc.
 - Proposed factory test location and field test procedures to demonstrate conformance to specifications, and the details of the accredited third-party testing authority.
 - Itemized bill of material listing for ozone generator components.
 - Spare parts list.
 - P&ID drawings.
 - Company profile and references.
 - Cost breakdown of various components of the generator and all appurtenances.
 - Timeframe and breakdown of schedule.
- d) All relevant technical information regarding each component or item proposed shall be reflected in the relevant section of the ITB (supplemented by additional information where deemed necessary by the Contractor), in order that the Owner can make a proper evaluation of the ITB.
- e) The Department of Watershed Management (DWM) prefers equipment and components that are manufactured in the United States as well as the provision of a local warehouse and access to local technical services representatives. Should items not be locally manufactured, the Contractor shall clearly identify these in their ITB and state how maintenance backup will be provided in the future.
- f) Where products of a particular supplier are specified, 'equal' products from other suppliers may also be offered if approval for such products has been obtained from the Owner.

2.4.4 Standards and Regulations

All materials and equipment shall be new and of the standard and quality specified.

The Contractor shall ensure that they are fully acquainted with the contents of the applicable Electrical Specifications.

All wiring installations shall comply fully with NEMA WC5 and UL 83 as amended.

The design and manufacture of equipment and the complete installation shall be carried out and tested in accordance with the latest issue or amendments of the following Regulations, as applicable:

- DeKalb County's Department of Watershed Management Design and Construction Standards
- Georgia Environmental Protection Division Minimum Standards for Public Water Systems
- Codes adopted and enforced by DeKalb County:
 - International Building Code, 2012 Edition, with Georgia Amendments
 - International Mechanical Code, 2012 Edition, with Georgia Amendments
 - International Plumbing Code, 2012 Edition, with Georgia Amendments
 - International Fire Code, 2012 Edition, with Georgia Amendments
 - International Energy Conservation Code, 2009 Edition, with Georgia Supplements and Amendments
 - NFPA National Electrical Code, 2014 Edition
 - 2012 NFPA 101 Life Safety Code with all Georgia State Amendments
 - Georgia Accessibility Code Chapter 120-3-20, as amended
 - 2010 Americans with Disabilities Act (ADA) Standards for Accessible Design
 - Any local electrical and instrumentation and controls (I&C) codes.

Utilities:

The Contractor will ensure that no utilities exist in the areas where breaking of concrete, excavations for new services, penetrations through walls or drilling for securing new

supports will take place. All necessary means will be exhausted to detect, protect and ensure that no concealed or visible cable, pipe or duct is damaged during the planning and execution of the project.

Demolition and Removal of Concrete, Pipes and Cables

The work will entail the demolition and removal of concrete supports/anchor bolts, piping, rubble and cables for the installation of the new generators. The existing sleeves through floors and walls for the generator cables and pipes will be assessed, and if found to be too few or too small to accommodate the new generator equipment, new ones will be constructed in consultation with the Owner. The structure of the generator building walls, floor and adjacent columns will be assessed by a professional structural engineer (Georgia PE) and recommendations made (and implemented) regarding any additional strengthening required for the new generators and any structural modifications required.

2.4.5 Environmental and Site Conditions

The following information pertains to the site works:

- Elevation above sea level < 1000 feet
- Nominal MV supply 4160 Volts (V); 3 phase; 60 Hertz (Hz)
- Nominal LV supply 480/277 V; 3 phase; 4 wire with earthed neutral
- Fault level To be determined by Contractor

The temperature of the generators located in Atlanta can reach up to 105°F, and therefore, the generators and PSUs shall have suitable cooling in order to maintain effective continuous operation.

Surge protection shall be provided on all 460 V distribution boards to generally limit the impulse level to 1 kilovolt (kV).

No other special allowances for short- or long-term over- or under voltages, impulses, transients, spikes, surges, mains borne interferences or power failures are provided. The Contractor shall ensure that all equipment, electrical or electronic, will be suitable for continuous, reliable operation under these circumstances, and the Contractor shall ensure that all equipment is adequately protected in this regard, whether such protection has been specified in detail or not.

Failure or malfunction of any component of the installation, even if attributable to the quality of power supply, shall be rectified at the Contractor's expense.

2.4.6 Testing

All Factory Performance Acceptance Tests as detailed above are to be performed by the Manufacturer for the Contractor and shall be witnessed by the Owner (the cost of travelling to the Manufacturer's testing facility by the Owner and his representatives will be borne by the Manufacturer).

Site testing and commissioning shall be in accordance with the Commissioning and Testing schedule above.

2.4.7 Notices and Labels

The Contractor shall be responsible for all notices and labels on the new generators and associated piping. All notices, labels and designations shall be in English. A list of wording, terms, designations, as well as examples of the labels, etc., shall be submitted for approval before manufacturing of labels and notices commences.

Equipment and terminals shall be marked clearly in accordance with the approved Drawings and SCWTP standards.

Equipment shall be labelled by means of a unique numbering system for ease of identification in line with the existing numbering system. The Contractor shall submit a numbering system for approval by the Owner.

Where labelling and direction of flow indicators are lacking on the pipework and instrumentation of the existing generator sets, they will also be enhanced and improved.

2.4.8 Uniformity of Equipment and Equipment Procured

Bid prices shall be based on equipment as referenced in the specifications herein. No alternatives will be allowed unless agreed upon in writing by the Owner.

2.4.9 Workmanship

The Contractor shall employ only competent staff to execute the installation.

The Contractor shall execute with the best workmanship in a workmanlike manner and to the satisfaction of the Owner.

Should any material or workmanship not be to the industry standard of care, it shall be rectified at the cost of the Contractor and all rejected material shall be removed from the site.

The Contractor shall be responsible for the correct and complete erection of the installation. Inspections by the Owner shall not release the Contractor from this responsibility.

2.4.10 Supervision

The Contractor shall provide full-time supervision while staff is working on the site.

The person designated by the Contractor to supervise the works shall have the authority to issue instructions on behalf of the Contractor.

2.4.11 Power Supply During Construction

The power supply is 480V 3 Phase. For single phase 120V power, the Contractor shall use its own step-down transformers. The Contractor is free to utilize this power to be able to undertake the work.

2.4.12 Power Supply Unit and Cooling Water

It is the responsibility of the Contractor to decide whether water cooling is required (to be determined at Bid) for the PSU. If water cooling is required, then the Contractor must include the requirements for a cooling water system in terms of quality, quantity, pressure and these shall be stated in the Bid. The cooling water for the PSUs and generators shall be a closed loop heat exchange system.

The Contractor shall design and provide harmonic mitigation evaluations and equipment with each ozone generator PSU, as required, to meet requirements as specified herein and provide written certification, signed by a representative of the Ozone Manufacturer that the Ozone System is in conformance with the harmonic standards specified. The following are applicable for the PSU:

- a) PSU power supplies shall incorporate harmonic mitigation equipment on the front end of the PSU connection to the distribution system. Mitigation equipment shall

be provided to meet the harmonic criteria for voltage and current distortion as specified herein.

- b) Details of the specific mitigation equipment shall be determined by the Contractor as required to ensure compatibility with the Contractor's design, meet all specified production requirements, maintain warranty, and achieve the performance criteria specified.
- c) At a minimum PSU technologies based on at least 18-pulse inverters (higher pulse counts are acceptable) or active front end power electronics only shall be acceptable. Other alternatives such as lower pulse count inverters with filters shall not be acceptable.

Factors Related to Power quality:

- a) Ozone Power Supply Units shall be certified compatible with the 277/480V, 3-phase, 4-wire electrical distribution systems as shown on the reference documents provided, without generation of voltage or current distortion in excess of that specified for total distortion or distortion of individual harmonic orders. The contractor shall measure the current electrical system to establish a baseline for the installation of the new units.
- b) For the purposes of the power quality performance parameters specified herein, the power quality parameter measurement points shall be defined as:
 - i) The 480V distribution panel bus serving the new units.
- c) The Ozone System Supplier shall note that the power quality measurement location as established under these Procurement Documents does not necessarily meet the formal definition of the PCC found in IEEE Recommended Practice 519 (2014). Further, the specified maximum values of voltage and current distortion and harmonic limits in these Documents are being applied within the WTP distribution systems again, not as defined formally under IEEE 519. The Contractor shall meet the specified distortion limits as defined within these Contract Documents regardless of the definitions and recommendations outlined in IEEE 519.
- d) Voltage distortion at the indicated locations shall meet the specified requirements as follows:
 - i) At the 480V distribution panel bus:
 - o 5% maximum harmonic distortion on individual integer multiples of the fundamental frequency,
 - o Total harmonic distortion less than 8%.
- e) Current Distortion:
 - i) All values shall be calculated in percent of the maximum fundamental demand current.

- ii) At the 480V distribution panel bus:
 - 3rd to 9th order: 4.0% maximum harmonic distortion
 - 11th to 15th order: 2.0% maximum harmonic distortion
 - 17th to 21st order: 1.5% maximum harmonic distortion
 - 23rd to 33rd order: 0.6% maximum harmonic distortion
 - 35th to 50th order: 0.3% maximum harmonic distortion
 - Even harmonics are limited to 25% of the odd harmonics limits shown
 - Current distortions that result in a DC offset, e.g., half-wave converters, are not allowed
 - Total harmonic demand distortion (TDD) less than 5%.
 - Cable termination boxes must be compatible with the existing installation.

2.4.13 Factory Testing of Power Supply Units (PSU)

Each PSU shall undergo an Owner-witnessed full factory acceptance test (FAT) and shall be tested at the Manufacturer's factory for example/at least temperature rise and power output in terms of the general specification attached.

The measurement of the temperature rise of the PSU shall be by the increase in resistance method.

Test certificates in duplicate, showing the results of all tests performed, shall be supplied at a date not later than the delivery date of the PSUs.

The test certificates shall contain power factor and efficiency figures for full load conditions as calculated from the test results.

2.4.14 Instrumentation

The Contractor shall be responsible for all instruments related to the monitoring of PSU, generators, flows, concentrations, temperatures, pressures, valves, etc. These signals must be relayed to the PLC.

The instrumentation shall be in accordance with the Contractor's design but with the minimum requirements as per the P&IDs of the existing generators and all appurtenant,

refer to Specifications and Functional Design of Existing Generator & Facilities **Exhibits**

2. The following will also be included:

- a) An automatic current limitation device to limit current under any operation condition, including surge or short circuit condition.
- b) An automatic ramp up control limiting the speed of rate of change from one power setting to another.
- c) Overvoltage protection.
- d) Overcurrent protection.
- e) Automatic shutdown on high temperatures.
- f) Programming of the PLC that the existing two generators have equal running hours going forward. The two new generators shall be programmed in a similar way.
- g) *Equipment and Instrumentation Identification*: All equipment and instrumentation (e.g., piping, valves and gates) shall be shown and identified with appropriate tags on the process and mechanical drawings. All devices shall be tagged in accordance with the P&IDs.
- h) *Equipment Data Sheets*: The Contractor shall develop an equipment data sheet and submit to the Owner for review. The data sheet shall be filled out completely for each piece of equipment selected. Data sheets are required for all process equipment, such as generators, motorized valves and process devices.
- i) *Calculations and Supporting Data*: The list below shows calculations or support data that shall be required as part of the mechanical work. The list shall not limit the Contractor from performing other calculations that are required for specific facilities or systems. Calculations for the following items are required for mechanical work:
 - iii) Pipe sizing and pressure ratings;
 - iv) Pressure-piping thrust forces and support designs;
 - v) Hydraulic calculations that support the selection of generators, which shall be accompanied by data sheets and generator production curves; and
 - vi) Valve and check valve sizing and closing times.

2.4.15 Operation and Maintenance Manuals and Computers

Two weeks before the Pre-Operation Checkout date, the Contractor shall submit three draft sets of complete O&M Manuals to maintain service and repair the installation. Data Books, which shall also be submitted, shall include all the factory and site test certificates and final test set-points.

Information included in the manuals shall be the following:

- Contact details of all suppliers of equipment.
- Descriptions of generator station and equipment installed.
- Wiring diagrams.
- All record (as-built) drawings, including P&IDs integrated with the existing generators and all appurtenant.
- Operation of the generator station, including full comprehensive operating philosophy/functional design specification.
- Standard operating procedures.
- Maintenance, disassembly and re-assembly procedures and schedules.
- Spare parts lists.
- Commissioning procedures.
- Decommissioning (mothballing) procedures.
- Training Manual and materials.

Six complete hard copy sets, including two electronic copies (one PDF version, one Word version and one CAD version), of the final Operation and Maintenance Manuals and Record (“As-Built”) Drawings, certified as accurate, shall be submitted to the Owner seven days after completion of the Acceptance Test.

The Contractor shall also provide two (2) laptop computers with O&M manuals, which will be as follows:

- Intel Core i7 processor with Windows operating system (latest version at time of implementation) and Microsoft Office (latest version at time of implementation).
- 17” high resolution screen, four-hour battery life (after one year), and internal DVD read/write drive.
- 16 Gigabyte RAM and 1 Terabyte solid-state memory drives.
- All PLC Software with programming keys uploaded.

2.4.16 Tools, Accessories and Spare Parts

The supply of all tools, special tools and accessories, required for the normal operation and maintenance of all the equipment and systems supplied, shall be included in the Contract.

All keys, tools and special tools shall be in duplicate and handed to the Owner upon completion. The Contract shall be deemed to be incomplete until this requirement has been met.

The Contractor shall ensure that all tools and equipment required are available during inspections and testing. This includes two-way radios, meters, keys, conductivity meters, bridging pieces and recorders as required. All blank flanges or spades will be supplied by the Contractor for piping and ozone generator pressure testing purposes.

As part of the Total Price, the Contractor shall include the spare parts as per the Manufacturer's recommendations. These will include all mechanical, electrical and instrumentation and control equipment. At least 5% spare dielectric tubes will be provided as part of the contract.

2.4.17 Maintenance and Guarantee

The equipment and installation included in this Contract shall have a warranty and the Contractor shall maintain all equipment in all respects for the duration of the Warranty Period of 24 months. The Warranty shall cover any leaks on all components/parts installed by the contractor. The Contractor will provide a sole warranty for all equipment and related workmanship provided as part of this contract, and no individual warranties from suppliers and vendors shall be accepted.

The Contractor shall, for the full duration of the Warranty Period, be responsible for all work and equipment replacements required, including labor, travelling costs, the replacement of lamps and fuses, etc. The Contractor shall repair/replace faulty equipment within 48 hours of notification.

In addition to the duties related to the warranties, the Contractor will be responsible for service visits at least every second month or as required for servicing the equipment for two years after completion.

The Contractor shall submit full details of his maintenance and repair service facilities, including statutory holidays, weekends, after hours and normal hours.

The Contractor shall stock the accepted list of spares during the Defects Notification Period. All repairs to be made to the installation due to causes not covered by the warranties (reasonable wear and tear only) shall be done utilizing the above spare parts.

At the end of the Warranty Period, the remaining material shall be documented and handed over to the Owner for the ongoing maintenance of the installation.

2.4.18 Installation Schedule and Penalties

Before any activities commence on site, the Contractor will prepare and submit a work plan of activities that will take place on site. The schedule shall clearly indicate when access will be required to any of the facilities that could impact the current operations, including access to the oxygen, nitrogen (if required), ozone manifolds, cooling water pipework, electrical and instrumentation equipment and cables, etc.

A detailed method statement indicating the procedure that will be followed to make modifications or install equipment shall also be submitted for approval prior to the commencement of any work. This shall include for tests to be done to ensure the existing isolation valves are in a proper working condition and are able to prevent any leaks when work needs to be conducted on piping or headers. The Contractor shall be responsible for contingency plans in the event of the isolation valves not being operational.

No disruption of the existing operations will exceed more than 3 (three) hours on any day. This time will not include for isolation and purging of headers/tie in points, which will be done in liaison with the operational staff at the Plant. The Liquidated Damages for any period longer than 3 (three) hours is \$1,000 per hour or any portion thereof.

The Contractor will still be required to obtain written permission 72 hours in advance of any operations to be interrupted and access required. Access to structures or equipment or the temporary disruption of operations may be delayed due to high water demands, however, the Contractor will be provided the necessary access within 14 days of the scheduled date.

2.4.19 REQUIRED BIDDER SUBMITTAL INFORMATION

The Bidder shall submit the following information with the Bid and include, at a minimum, the information as described in this Section of the Contract Documents:

A. Submittal of Shop Drawing:

- i. Submit along with Bid manufacturers Shop Drawings and data for material being proposed allowing the Evaluation Team to review and compare materials.

- ii. Technical Data submitted shall be in accordance with the Specification Section and or technical criteria for that specific material, i.e. pump / valve
- iii. Unless specified otherwise in the Bid Documents, Shop Drawings shall include the following at a minimum:
 - Data curves showing how power consumption (kwh/lbs.) varies with varying ozone production rates.
 - The curves shall cover an ozone production range from 8 to 100 percent of its maximum ozone production capacity of 2000 PPD, at ozone concentrations of 6% to 12% by weight.
 - Design data for the ozone generator and power supply.
 - Proposed factory test location and field test procedures to demonstrate conformance to specifications, and the details of the accredited third-party testing authority.
 - Utility, Civil, Electrical, Mechanical, HVAC & P&ID drawings. (30% drawings).