

April 16, 2021

**TO:** All Bidders under Invitation to Bid No. 21-101346

**FROM:** Department of Purchasing and Contracting, DeKalb County, Georgia

**ADDENDUM NO. 2**

Invitation to Bid (ITB) No. 21-101346 Manhole Castings and Accessories (Three (3) Multiyear Contract) hereby amended as follows:

1. The question period is reopened through Friday, April 23, 2021.
2. Exhibit 1 of this addendum shall be included in the Minimum Specifications for this ITB.
3. Exhibit 2 shall replace specifications and/or drawings for the item numbers as indicated in the attachment.
4. It is the responsibility of each bidder to ensure that he is aware of all addenda issued under this ITB. Please sign and return this addendum. You may email Judi Moore at [jmoore@dekalbcountyga.gov](mailto:jmoore@dekalbcountyga.gov) before the bids are due to confirm the number of addenda issued.
5. All other conditions remain in full force and effect.

*Judi Moore*

Judi Moore  
Procurement Agent  
Department of Purchasing and Contracting

**ACKNOWLEDGMENT**

Date: \_\_\_\_\_

Addendum No. 2 to ITB 21-101346 is hereby acknowledged:

\_\_\_\_\_  
(NAME OF BIDDER)

\_\_\_\_\_  
(Signature)

\_\_\_\_\_  
(Title)

Agent *gm*:

## EXHIBIT 1

### ADDITIONAL MINIMUM SPECIFICATIONS



#### V-1326-2/1327 Sanitary Sewer Assembly DeKalb County, Georgia Specification

##### **General**

This specification is applicable for gray iron and ductile iron construction castings. Castings shall be made in USA and shall be EJ Model number 41327066A01 or approved equal. Approved equal must meet the requirements of this specification.

##### **Material**

Manufacturer shall certify that the gray iron conforms to ASTM A48/AASHTO M105 Class 35B. Castings must contain a minimum of 85% recycled content.

##### **Markings**

All products shall have the product name or series number (example: 1326-2), country of origin, specific part number, production date, material information, and the manufacturer's identification or name (EJ) permanently cast on the product. The top of manhole covers shall have the country of origin and manufacturer's identification. Cover must have "Property of DeKalb County" custom lettering permanently cast into the top radius of the cover and "Sewer" permanently cast into the middle of the cover. The bottom of the casting shall have the product name or series number, part number, production date (example: mm/dd/yy) for tracking purposes, and material quality (such as ASTM A48 or ASTM A536) to verify the materials used. Castings without proper markings shall be rejected.

##### **Product Specifics**

Covers shall come equipped with two (2) non-penetrating ergonomic pick slots for safety and ease of removal by one operator, with one "J" style hook or similar. Each pick slot shall have dual openings for ease of removal of any debris. The pick slots shall be the EPIC® pick bar as designed by EJ USA, INC. or approved equal.

##### **Covers and Frames**

Standard frames & covers shall be made from gray iron conforming to ASTM A48, Class 35B & AASHTO M105, Class 35B. Covers can be made from ductile iron, upon request. Castings shall be of uniform quality, free from sand holes, gas holes, cracks, shrinkage and other surface defects. Castings shall be reasonably well cleaned by shot blasting. Runners, risers, fins and other cast-on pieces shall be removed from the castings and such areas shall be ground smooth. As-cast dimensions may vary within accepted foundry tolerances as outlined in the Iron Castings Handbook published by the American Foundrymen's Society, Inc. Nominal, casting dimensional tolerances shall be +/- 1/16 inch per foot. Castings shall be furnished uncoated.

##### **Product Options**

If desired, the product shall be provided with customer specific labeling.  
Certification/Standards Compliance  
AASHTO M105 Material  
ASTM A536 Material  
ISO 9001:2008 Quality Assurance

##### **Quality Assurance**

System of manufacturing quality assurance must conform to the requirements of ISO 9001:2008 and be certified by a third party. Producing foundry must be an approved supplier to Georgia State Department of Transportation.

EXHIBIT 2

DRAWINGS AND SPECIFICATIONS

FOR

ITEM NOS. 1, 3, 7, 10, 13, 16, 22, 25, 28, 29, & 31



# V5724 V5724-4 Assembly

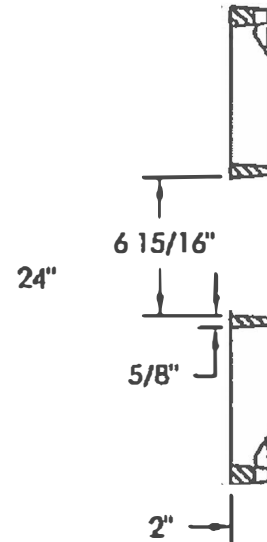
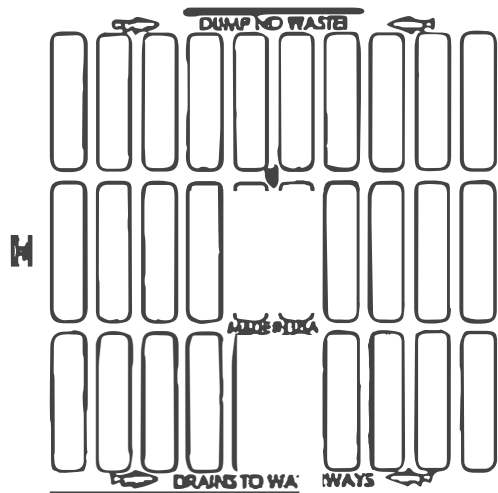

**GRATE SECTION**

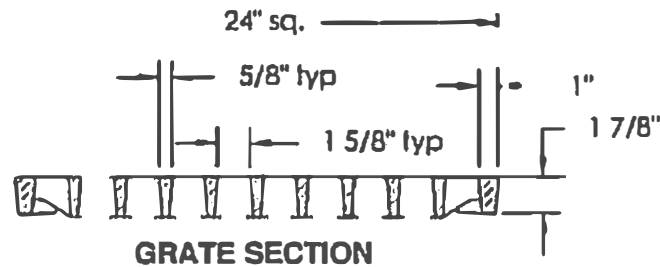

**GRATE SECTION**

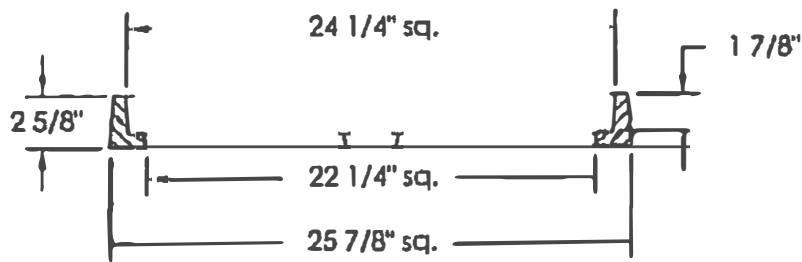

**FRAME SECTION**

Product Number  
**45724007**

Design Features

- Materials
- Frame  
Gray Iron (CL35B)
- Grate  
Ductile Iron (70-50-05)

- Design Load
- Heavy Duty
- 60,000 Lbs. Proof Load Rated

- Open Area
- 336 sq in

- Coating
- Undipped

- Designated Machined Surface

Weight  
153 lb

Certification

- ASTM A536
- ASTM A48
- Country of Origin: USA

Major Components

45724010  
45724431

Drawing Revision

9/11/2008 Designer: GAD  
4/20/2016 Revised By: MAH

Disclaimer

Weights (as a g) dimensions (inches) and drawings provided for your guidance. We reserve the right to modify specifications without prior notice.

CONFIDENTIAL: This drawing is the property of EJ GROUP, Inc. and embodies confidential information, registered marks, patents, trade secret information, and/or know how that is the property of EJ GROUP, Inc. Copyright © 2012 EJ GROUP, Inc. All rights reserved.

Contact

800 626 4653  
ejco.com



# V5763FR V5763GR Assembly

Addendum Page

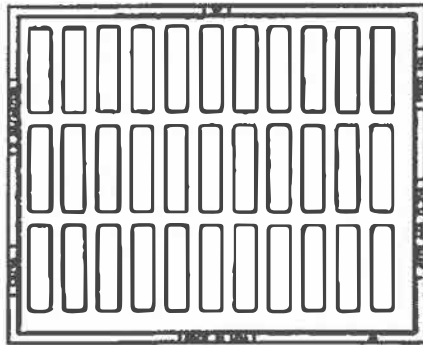

PLAN VIEW

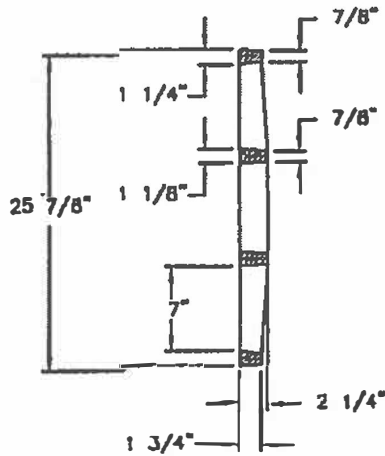

GRATE SECTION

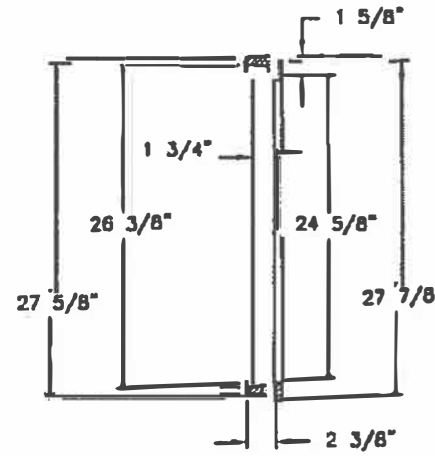

FRAME SECTION

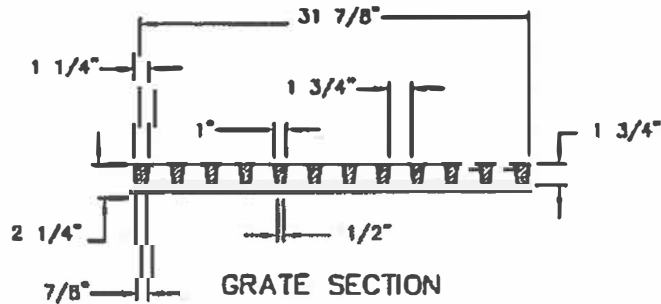

GRATE SECTION

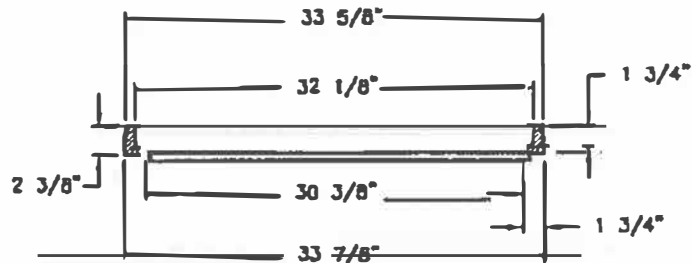

FRAME SECTION

Product Number

45763001

Design Features

- Materials
- Frame  
Gray Iron (CL35B)
- Gate  
Gray Iron (CL35B)

- Design Load  
Heavy Duty
- Open Area  
402 Sq. Inches
- Coating  
Undipped
- Designates Machined Surface

Certification

- ASTM A48
- Country of Origin: USA

Major Components

45763010  
45763030

Drawing Revision

12/11/2002 Designer: DEW  
02/16/2017 Revised By: DVD

Disclaimer

Weights (lbs.) dimensions (inches/mm) and drawings provided for your guidance. We reserve the right to modify specifications without prior notice.

CONFIDENTIAL: This drawing is the property of EJ GROUP, Inc., and embodies confidential information, registered marks, patents, trade secret information, and/or know how that is the property of EJ GROUP, Inc. Copyright © 2012 EJ GROUP, Inc. All rights reserved.

Contact

800 626 4653  
ejco.com

Addendum



# V4280 V4280-1 Assembly

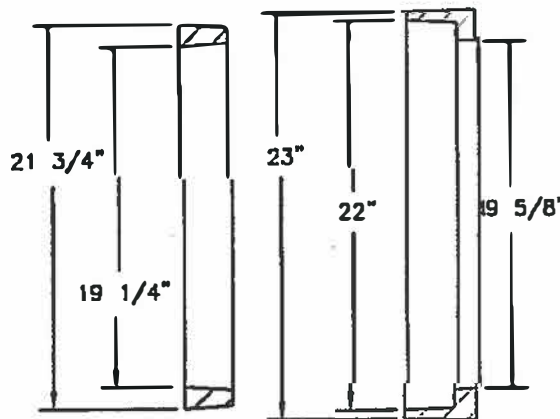
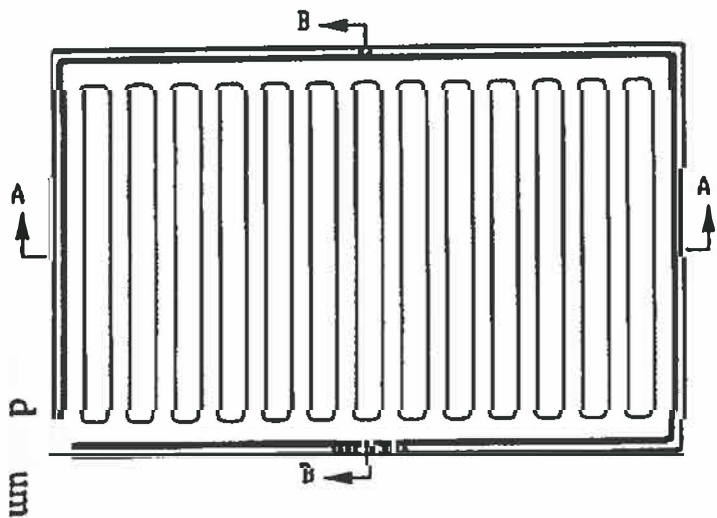

GRATE SECTION

SECTION B-B

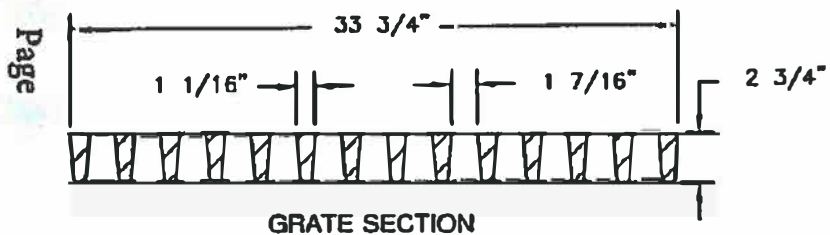

GRATE SECTION

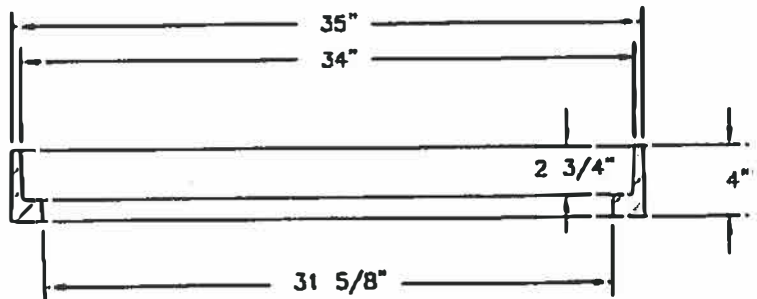

SECTION A-A

Product Number  
44280160

Design Features

- Materials
- Frame  
Gray Iron (CL35B)
- Grale  
Gray Iron (CL35B)

-Design Load  
Heavy Duty

-Open Area  
361 sq in

-Coating

Undipped

- Designates Machined Surface

Certification

- ASTM A48

-Country of Origin:USA

Major Components

44280010

44280130

Drawing Revision

08/09/2000 Designer: PFB

10/27/2014 Revised By: DJH

Disclaimer

Weights (lbs./sq) dimensions (inches/mm) and drawings provided for your guidance. We reserve the right to modify specifications without prior notice.

CONFIDENTIAL: This drawing is the property of EJ GROUP, Inc. and embodies confidential information, registered marks, patents, trade secret information, and/or know how that is the property of EJ GROUP, Inc. Copyright © 2012 EJ GROUP, Inc. All rights reserved.

Contact

800 626 4653

ejco.com

ppv

m No

00



# V5760FR V5760GR Assembly

Adde

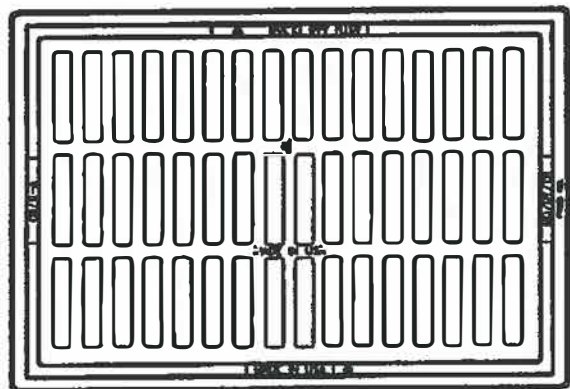

PLAN VIEW

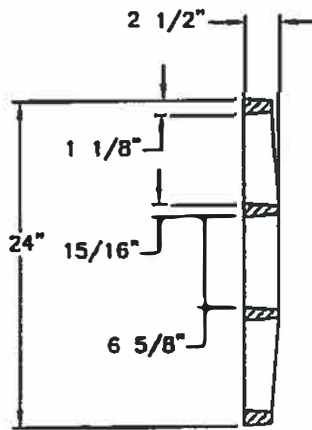

GRATE SECTION

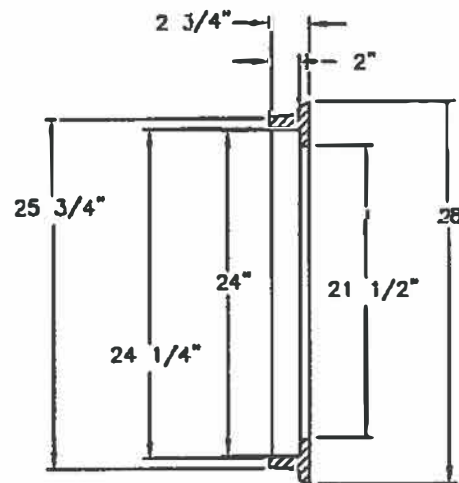

FRAME SECTION

0.5

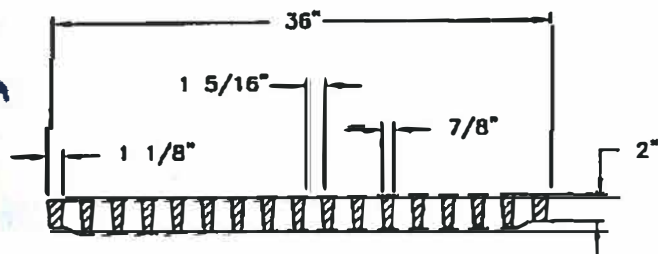

GRATE SECTION

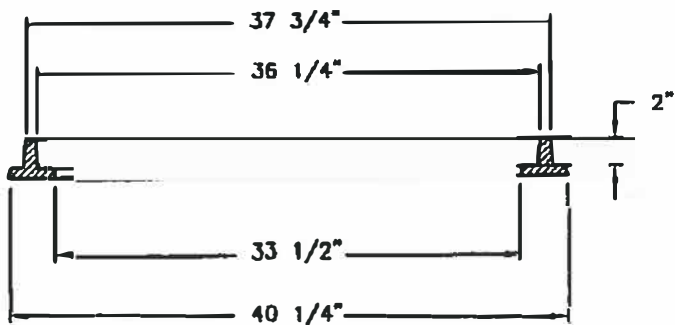

FRAME SECTION

**Product Number**  
45760002

**Design Features**

- Materials
- Frame
- Gray Iron (CL35B)
- Grate
- Gray Iron (CL35B)

- Design Load
- Heavy Duty
- Open Area
- 413 Sq. Inches
- Coating
- Undipped
- Designates Machined Surface

**Certification**

- ASTM A48
- Country of Origin: USA

**Major Components**

- 45760010
- 45760030

**Drawing Revision**

- 12/11/2002 Designer: DEW
- 09/08/2016 Revised By: DVD

**Disclaimer**

Weights (lbs/kg) dimensions (inches/mm) and drawings provided for your guidance. We reserve the right to modify specifications without prior notice.

**CONFIDENTIAL:** This drawing is the property of EJ GROUP, Inc., and embodies confidential information, registered marks, patents, trade secret information, and/or know how that is the property of EJ GROUP, Inc. Copyright © 2012 EJ GROUP, Inc. All rights reserved.

**Contact**

800 626 4653  
ejco.com

m No. 5



# V5732FR V5732GR Assembly

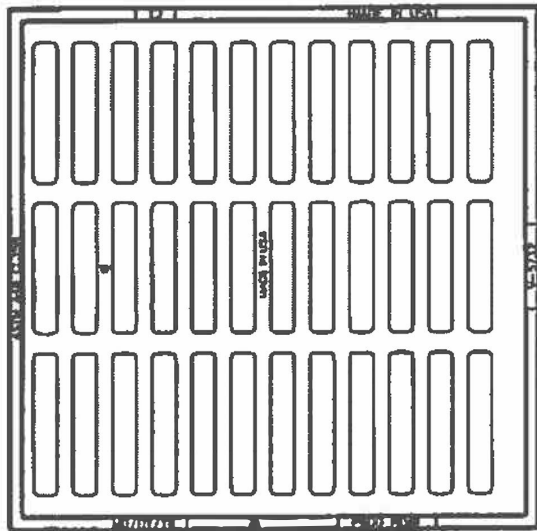

PLAN VIEW

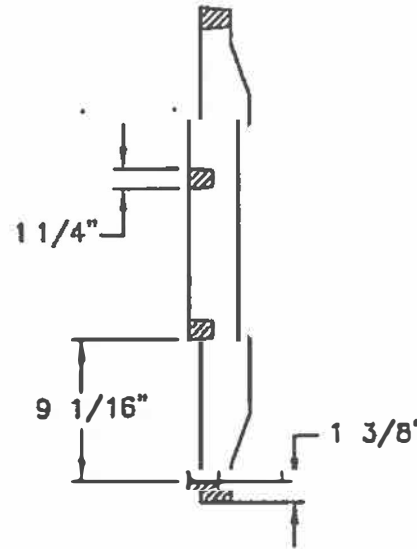

GRATE SECTION

Page 0

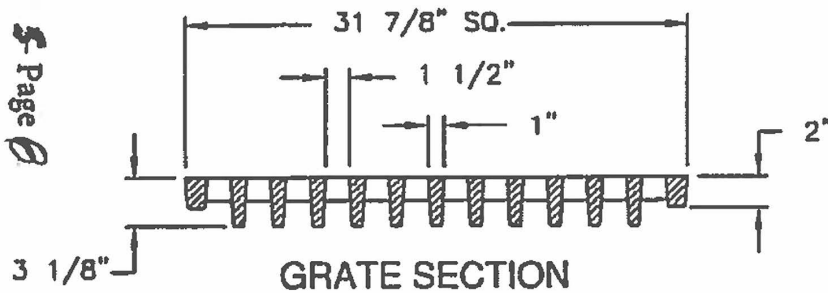

GRATE SECTION

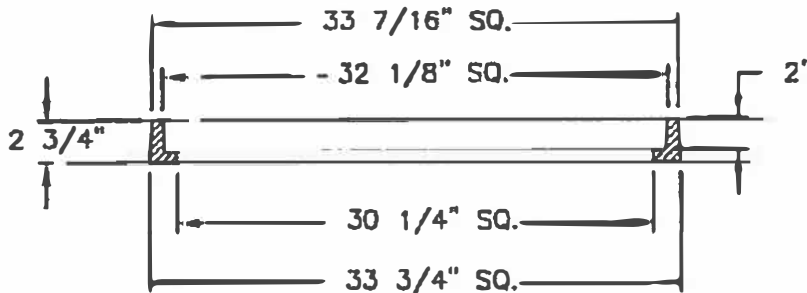

FRAME SECTION

Product Number

45732003

Design Features

- Materials
- Frame  
Gray Iron (CL35B)
- Grate  
Gray Iron (CL35B)

- Design Load  
Heavy Duty
- Open Area  
490 Sq. Inches
- Coating  
Undipped
- Signales Machined Surface

Certification

- ASTM A48
- Country of Origin: USA

Major Components

45732010  
45732030

Drawing Revision

11/05/2002 Designer: TCL  
09/08/2016 Revised By: DVD

Disclaimer

Weights (lbs./sq.) dimensions (inches/mm) and drawings provided for your guidance. We reserve the right to modify specifications without prior notice.

CONFIDENTIAL This drawing is the property of EJ GROUP, Inc., and embodies confidential information, registered marks, patents, trade secret information, and/or know how that is the property of EJ GROUP, Inc. Copyright © 2012 EJ GROUP, Inc. All rights reserved. Contact

800 626 4653  
ejco.com



# V5736FR V5736GR Assembly

1/2" FLAT FACE GOTHIC

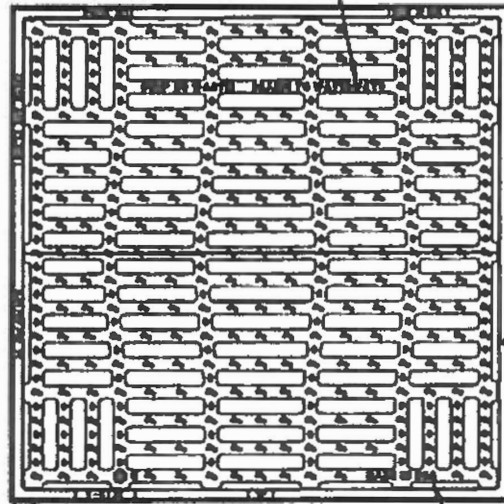

PLAN VIEW

1/2" FLAT FACE GOTHIC

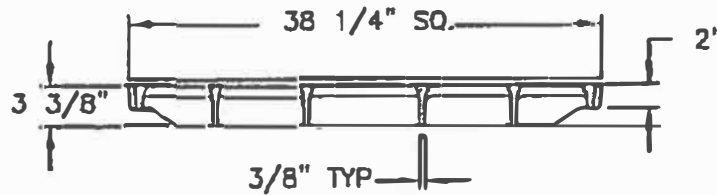

GRATE SECTION

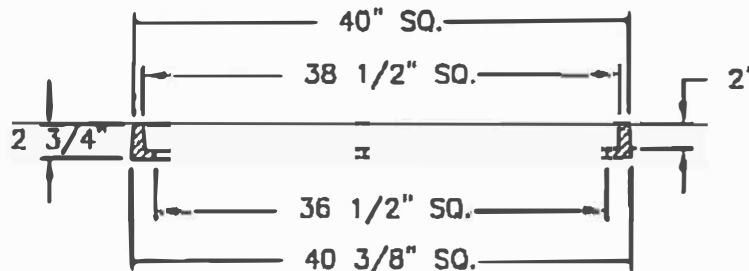

FRAME SECTION

Addendum

Page

Addendum

Product Number  
45736003

Design Features

- Materials
  - Frame  
Gray Iron (CL35B)
  - Grate  
Ductile Iron (70-50-05)

- Design Load  
Heavy Duty
- Open Area  
673 Sq. Inches
- Coating  
Undipped
- Designates Machined Surface

Certification

- ASTM A48
- ASTM A536
- AASHTO M305
- Country of Origin: USA

Major Components

- 45736010
- 45736030

Drawing Revision

- 11/05/2002 Designer: TCL
- 09/12/2016 Revised By: DVD

Disclaimer

Weights (lbs./sq.) dimensions (inches/mm) and drawings provided for your guidance. We reserve the right to modify specifications without prior notice.

CONFIDENTIAL: This drawing is the property of EJ GROUP, Inc. and contains confidential information, registered marks, patents, trade secret information, and/or know how that is the property of EJ GROUP, Inc. Copyright © 2012 EJ GROUP, Inc. All rights reserved.

Contact

- 800 826 4653
- ejco.com

# G1860RG G1860CV Assembly

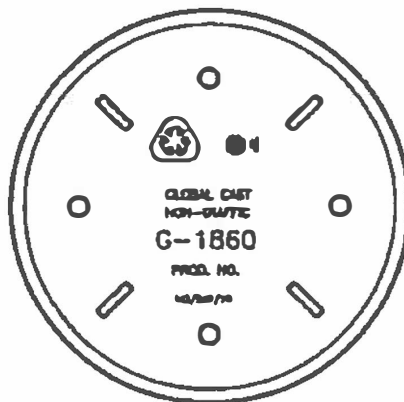
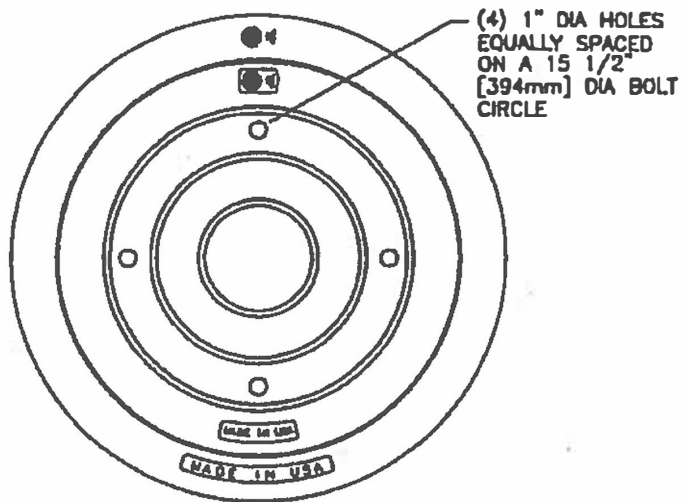

BOTTOM VIEW

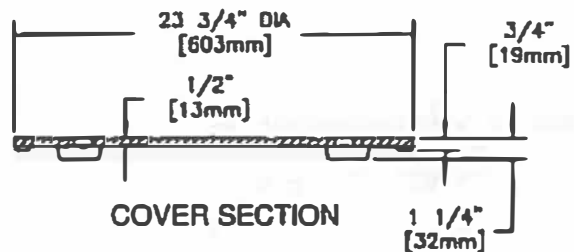

COVER SECTION

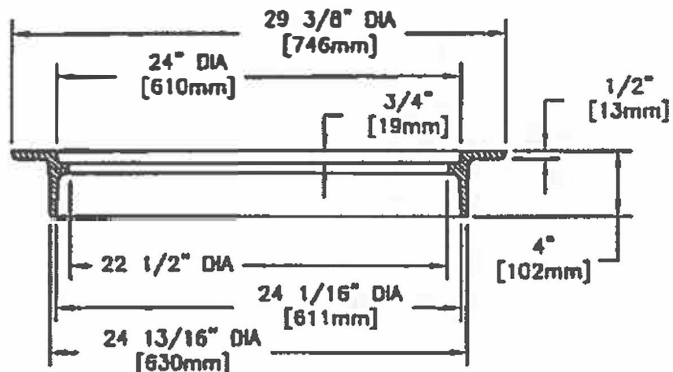

FRAME SECTION

**Product Number**

05186062

**Design Features**

- Materials
- Frame  
Gray Iron (CL35B)
- Cover  
Gray Iron (CL35B)

- Design Load  
Non-Traffic

- Open Area  
r/a
- Coating  
Undipped

- Designates Machined Surface

**Certification**

- Country of Origin: USA

**Major Components**

05186010  
05186021

**Drawing Revision**

12/07/2002 Designer: DEW  
8/9/2017 Revised By: CSF

**Disclaimer**

Weights (to A) dimensions (inches/mm) and drawings provided for your guidance. We reserve the right in modify specifications without prior notice.

CONFIDENTIAL: This drawing is the property of EJ GROUP, Inc., and embodies confidential information, registered marks, patents, trade secret information, and/or know how that is the property of EJ GROUP, Inc. Copyright © 2012 EJ GROUP, Inc. All rights reserved.

**Contact**

800 626 4653  
ejco.com

V1326-2

V1327

Assembly

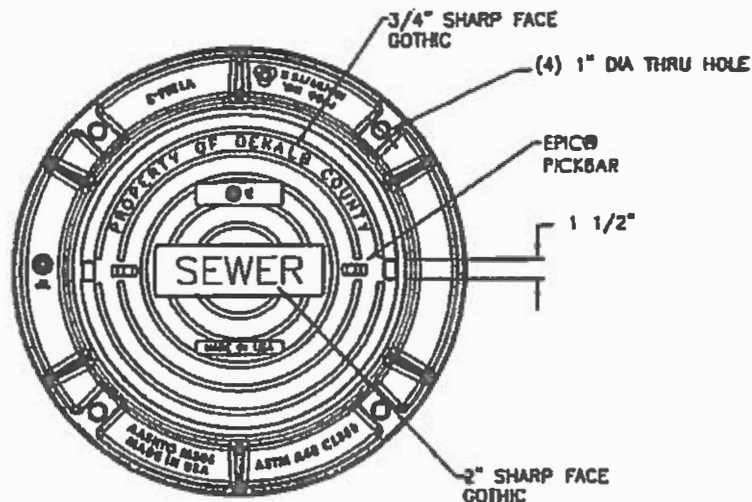

PLAN VIEW

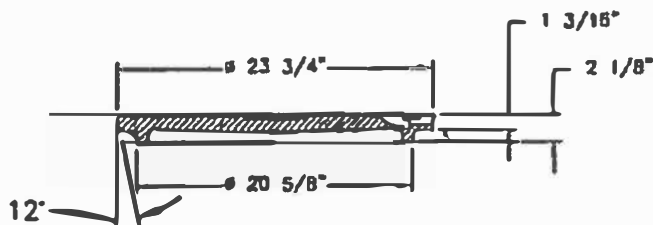

COVER SECTION

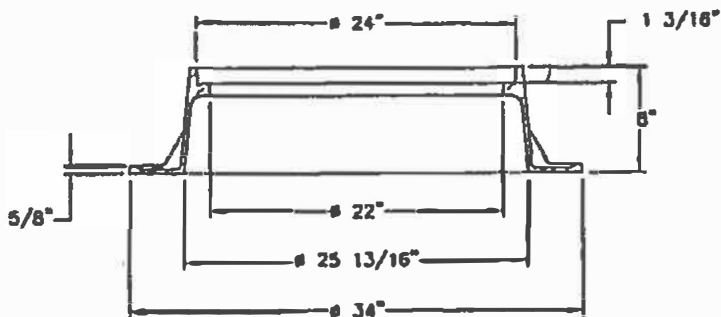

FRAME SECTION

Product Number  
**41327066A01**

Design Features

- Materials
- Cover  
    Gray Iron (CL35B)
- Frame  
    Gray Iron (CL35B)

- Design Load  
  Heavy Duty
- Open Area  
  n/a
- Coating  
  Undipped
- / Designates Machined Surface

Certification

- ASTM A48
- Country of Origin: USA

Major Components

41327066  
 41326211

Drawing Revision

08/09/2017 Designer: MAH  
 01/10/2017 Revised By: MAH

Disclaimer

Weights (lbs.) and dimensions (inches/mm) and drawings provided for your guidance. We reserve the right to modify specifications without prior notice.

**CONFIDENTIAL** This drawing is the property of EJ GROUP, Inc. and embodies confidential information, registered marks, patents, trade secret information, and/or know how that is the property of EJ GROUP, Inc. Copyright © 2013 EJ GROUP, Inc. All rights reserved.

Contact

800 626 4653  
 ejco.com

du 7-0089

den



# V2327 Assembly

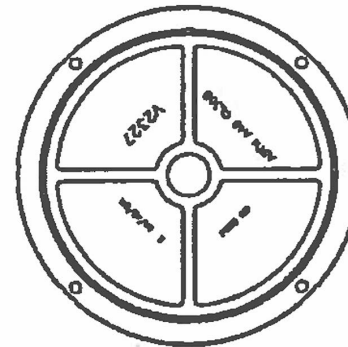
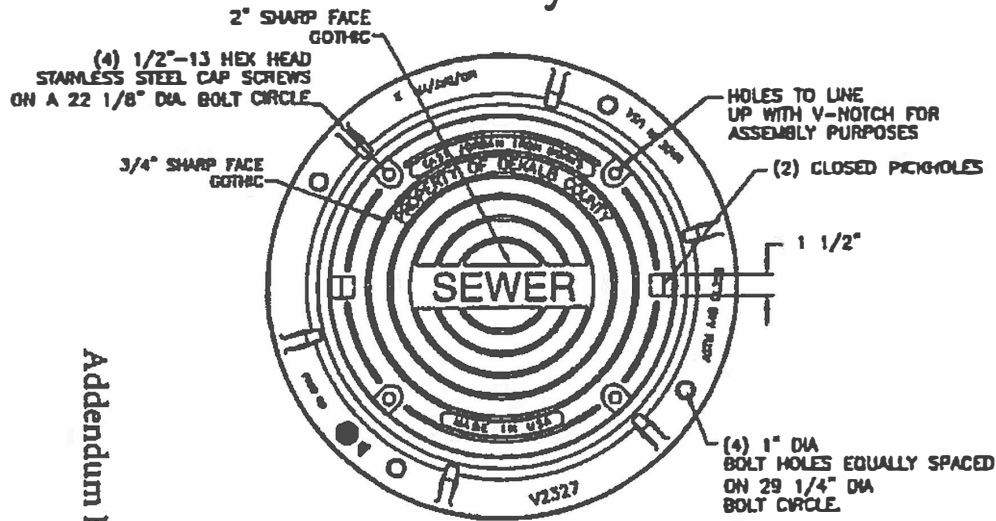

COVER BACK

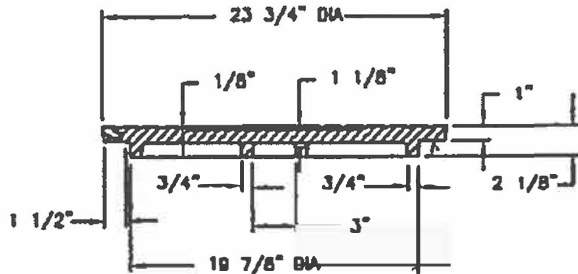

SECTION OF COVER

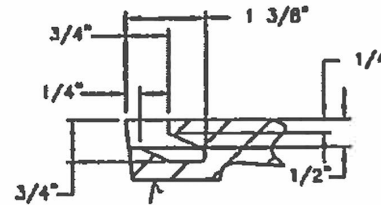

PICKHOLE DETAIL

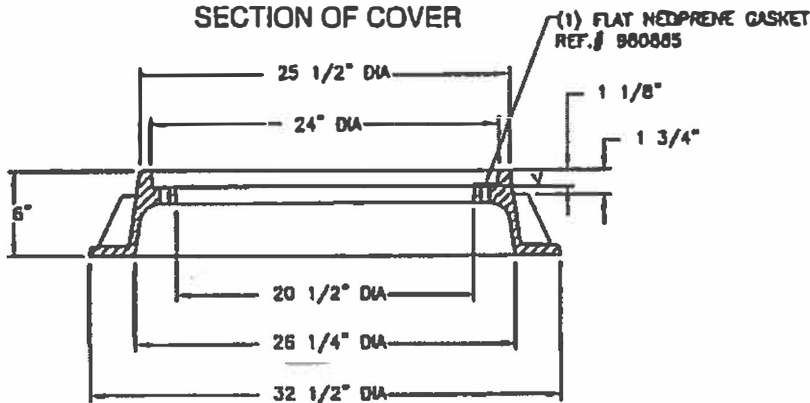

FRAME SECTION



BOLT HOLE DETAIL

**Product Number**

42327046W01

**Design Features**

- Materials
- Frame  
Gray Iron (CL35B)
- Cover  
Gray Iron (CL35B)

- Design Load  
Heavy Duty

- Open Area  
n/a
- Coating  
Undipped
- Designates Machined Surface

**Certification**

- ASTM A48
- Country of Origin: USA

**Major Components**

42327010  
42327046

**Drawing Revision**

2/4/2013 Designer: DJH  
7/29/2014 Revised By: DAE

**Disclaimer**

Weights (lbs./kg) dimensions (inches/mm) and tolerances provided for your guidance. We reserve the right to modify specifications without prior notice.

**CONFIDENTIAL:** This drawing is the property of EJ GROUP, Inc. and embodies confidential information, registered marks, patents, trade secret information, and/or know how that is the property of EJ GROUP, Inc. Copyright © 2012 EJ GROUP, Inc. All rights reserved.

**Contact**

800 626 4653  
ejco.com

Addendum No. 5 - Page 1/2

du No. 008 M n Spec ficat ns



# V2327 Cover

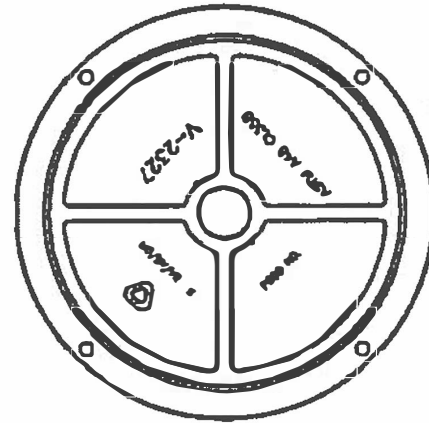
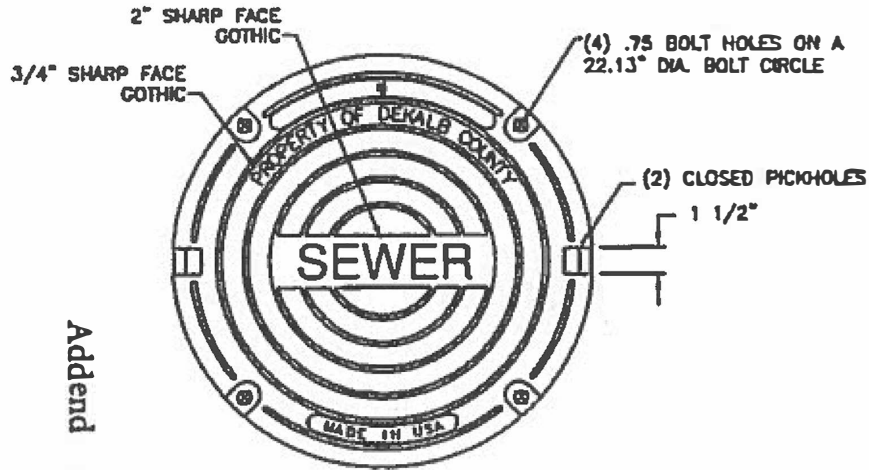

Product Number

42327046

Design Features

- Materials  
Gray Iron (CL35B)
- Design Load  
Heavy Duty
- Open Area  
n/a
- Coating  
Undipped
- Designates Machined Surface

Certification

- ASTM A48
- Country of Origin: USA

Drawing Revision

2/4/2013 Designer: DJH  
06/09/2016 Revised By: TWN

Disclaimer

Weights (lbs/lb) dimensions (inches/mm) and drawings provided for your guidance. We reserve the right to modify specifications without prior notice.

CONFIDENTIAL: This drawing is the property of EJ GROUP, Inc., and embodies confidential information, registered marks, patents, trade secret information, and/or know how that is the property of EJ GROUP, Inc. Copyright © 2012 EJ GROUP, Inc. All rights reserved.

Contact  
800 626 4653  
ejco.com

Addend

gc

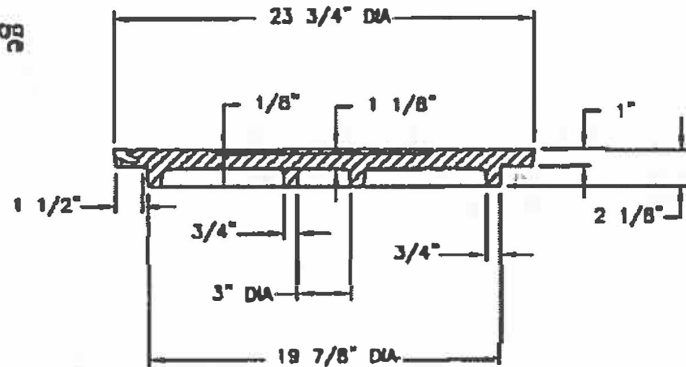

COVER SECTION

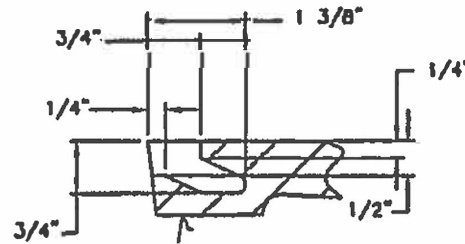

PICKHOLE DETAIL



BOLT HOLE DETAIL

00

S in

# V1327 Cover

ITEM NO. 31

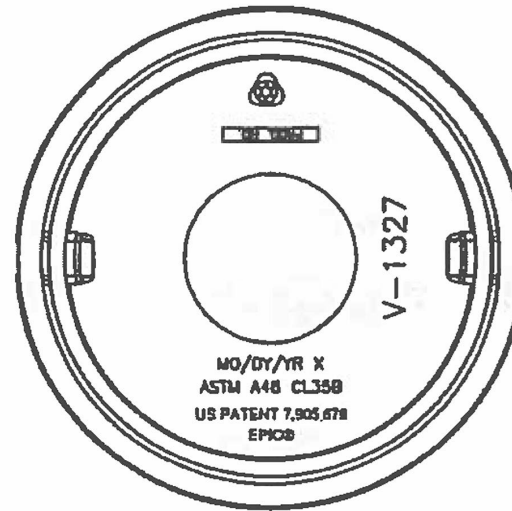
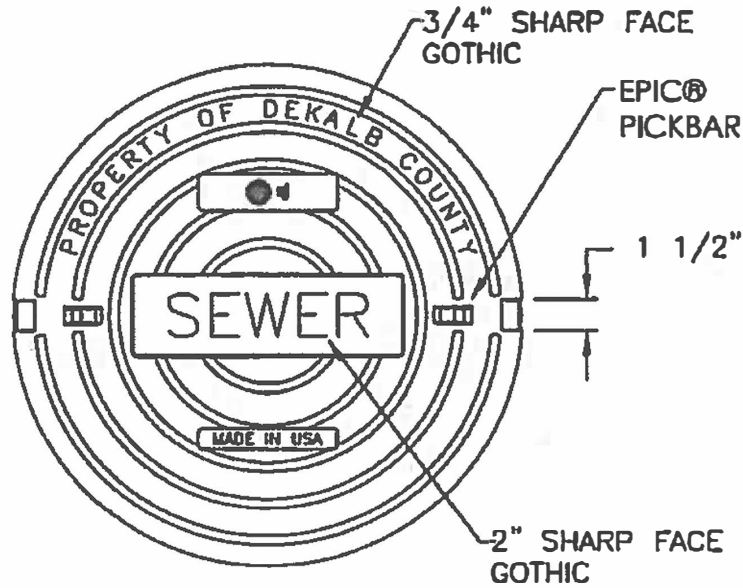

**BOTTOM VIEW**

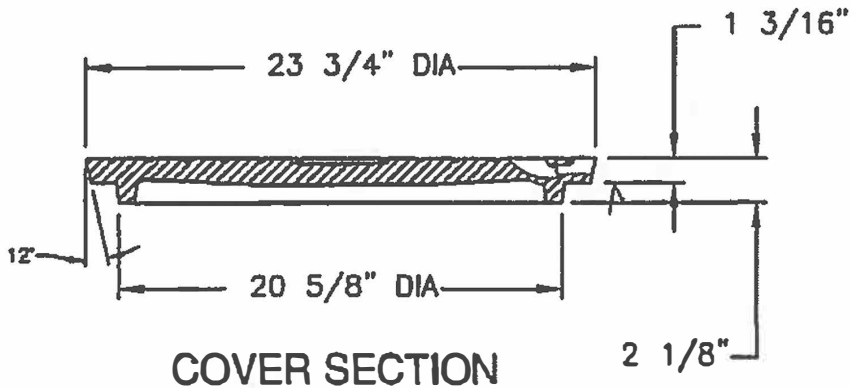

**COVER SECTION**

**41327066**

**Design Features**

- Materials  
Gray Iron (CL358)
- Design Load  
Heavy Duty
- Open Area  
n/a
- Coating  
Undipped
- Designates Machined Surface

**Estimated Weight**

- 138 lb.

**Certification**

- ASTM A48
- Country of Origin:USA

**Drawing Revision**

- 5/24/2017 Designer: MAH
- 10/3/2017 Revised By: MAH

**Disclaimer**

Weights (lbs./kg) dimensions (inches/mm) and drawings provided for your guidance. We reserve the right to modify specifications without prior notice.

**CONFIDENTIAL:** This drawing is the property of EJ GROUP, Inc., and embodies confidential information, registered marks, patents, trade secret information, and/or know how that is the property of EJ GROUP, Inc. Copyright © 2012 EJ GROUP, Inc. All rights reserved.

**Contact**

800 626 4653  
ejco.com