

DeKalb County Fire Rescue

Physical Ability Test (PAT)

Revised 03-31-2015

Scope:

This standard identifies the physical ability requirements for people who are applying to be firefighters with Dekalb County Fire Rescue.

Purpose:

The physical ability test is intended to determine an applicants' ability to demonstrate an adequate level of physical conditioning and dexterity.

The evolutions contained in this evaluation are not intended to be a test of the maximum abilities of the applicant. The participant will be expected to demonstrate a minimum level of physical ability and skill in order to complete the exercise in the allotted time.

Description:

The physical ability test consists of six evolutions that are to be performed in the following order:

1. Rescue Drill
2. Roof Ventilation (Keiser Sled)
3. Hose Drag
4. Roof Ladder
5. Tower Climb
 - a. Equipment Hoist 5th story
6. K-12 Saw Operation

Time Constraint:

The applicant must complete the entire exercise in 20 minutes or less.

Additional Evolutions:

Two additional evolutions are to be performed. They are not included in the 20 minute time frame. These two evolutions are pass/fail.

1. Aerial Ladder Climb (5 minutes)
2. Crawl/ Search Drill (5 Minutes)

Physical Ability Test Requirements:

An information sheet shall be completed before starting the PAT. This information will be used to track the total physical conditioning. All personal information gathered shall be kept confidential.

A pretest screening of a resting pulse and blood pressure will be measured. If any element is out of normal range, the applicant will not take the Physical Ability Test without a physician's clearance.

During the exercise, the participant will wear a protective helmet, gloves, and an SCBA. They will not wear full protective gear and they will not be on air.

Participants should wear closed toe shoes or sneakers, pants and a t-shirt, or comfortable athletic attire

At no time shall the participant be allowed to run during the PAT, running may cause serious injuries to the back and legs. The participant may “**speed walk**” while moving between evolutions.

Speed walking

The sport of walking for speed, the rules of which require the racer to maintain continual foot contact with the ground and keep the supporting leg straight at the knee when that leg is directly below the body. Also called health walking, race walking, heel-and-toeing, power walking.

■ Race walker noun ¹

Goal:

Determine the overall physical conditioning of the participant applying to be a firefighter with Dekalb County Fire Rescue. The PAT is designed as a minimum accepted level of job performance. A time of 20 minutes has been established as the target goal.

There are two additional evolutions that simulate actions possibly performed by firefighters. Each of these evolutions has a 5 minute time limit.

Failure:

If the participant does not complete the requirements for each drill or if the participant does not finish within the 20-minute time constitutes failure. If at any time an instructor stops you it is because you are endangering yourself or another’s safety.

RESCUE DRILL

Requirement:

The participant shall rescue a 165 lb. mannequin.

Job Relatedness:

One of the most important functions of the firefighters’ job is that of rescue. It is imperative that the firefighter be able to demonstrate and perform the skills necessary to rescue a person when duty calls.

Procedure:

An anatomically correct mannequin weighing 165 lbs. is placed on the ground in a supine position. The participant will move the victim a distance of 50 feet around a cone/barrel and back to the starting point. The total distance is 100 feet.

Tips:

The mannequin has a 44-inch chest. Some rescuers find difficulty reaching around the mannequin. A harness has been placed around the arms to simulate clothing.

¹ Excerpted from *The American Heritage® Dictionary of the English Language, Third Edition* © 1996 by Houghton Mifflin Company.

Use proper lifting techniques. For example, use your legs to lift the mannequin and not your back.

Failure:

Not crossing the line or handling the rescue victim unsafely.
Wrapping the harness strap around any hand/ body part
Walking forward while attempting to drag the mannequin

ROOF VENTILATION

Requirement:

Strike the I-beam of a Keiser Sled Roof Simulator using a 9lb dead blow hammer with sufficient force to move the beam 35 inches.

Job Relatedness:

In order to effectively remove smoke, fire, and super heated gasses from attic spaces, the firefighter must be able to use tools and equipment on a roof to perform vertical ventilation.

Procedure:

The ventilation evolution will be performed on the Keiser Sled roof simulator next to the burn building. Once the participant arrives at the simulator, he/she shall grasp the dead blow hammer located along side of the Keiser Sled. Upon reaching the Keiser Sled, the participant shall straddle the I-beam by standing on the foot walks and strike the I-beam of the simulator with sufficient force to move the I-beam 35 inches. The participant must have eye protection on (goggles or helmet shield) while striking the simulator. After successfully striking the simulator return the dead blow hammer to its original location.

Failure:

Failure to move the I-beam the marked distance
Losing control of the dead blow hammer
Stepping off the foot walks during the evolution

CHARGED HOSE DRAG

Requirement:

Drag a designated section of charged 1 3/4 - inch hose 50 feet.

Job Relatedness:

The 1 3/4-inch hose is carried on all fire engines and is widely used on the fire ground. Firefighters are routinely required to perform this equivalent task.

Procedure:

The participant shall pick up the designated section of 1 3/4 - inch hose and advance it 50 feet. The hose must be advanced past the cone/barrel located 50 feet away then placed in the designated location.

Tips:

This is the time to catch your breath. The next two evolutions require no great stamina, just skill to complete.

Failure:

Failure to advance the hose the required distance

PROCEED TO THE TOWER**LADDER HANDLING****Requirement:**

Remove a 14-foot roof ladder from the side of the tower wall and place it on the ground

Job Relatedness:

Ladders play a key role in fire ground operations. They are used in ventilation, rescue, and extinguishments and to assist firefighters in many other ways; so, they can successfully complete their task on a fire scene.

Procedure:

This evolution consists of removing a ladder from the engine/ wall and placing it on the ground, then placing it back onto the hooks on the engine/wall 3 times.

Grasp the roof ladder at the midpoint for balance and lift off of the rack located on the side of the tower. Place the ladder on the ground so that the beam of the ladder rests evenly on the ground.

Pick the ladder up maintaining control and place on the hooks on the engine/ wall of the tower.

Repeat this process 3 times.

Tip:

Grasp the ladder at the midpoint and space hands evenly for control.

Failure:

If the ladder makes early contact with ground or an inability to control the ladder will constitute failure

If the beam of the ladder is not completely on the ground

TOWER CLIMB & EQUIPMENT HOIST**Requirement:**

Walk up a seven-story building carrying a 50 foot section of 2 ½ -inch hose upon reaching the 5th story the participant will hoist a 35 lb. section of hose from the ground up to the 5th story.

Job Relatedness:

In order to perform a firefighter's duties on a daily basis, it is imperative that a firefighter is physically able to perform strenuous acts such as climbing numerous flights of stairs while carrying equipment or hoisting hose or other equipment.

Procedure:

After completing the ladder evolution, the participant shall walk to the rear of the tower, pick up a hose bundle consisting of 50 feet of 2 ½ -inch hose then enter the rear door and proceed to the 5th floor.

The participant will place the hose bundle on the ground in the stairwell and go out to the balcony and hoist a 35 lb. hose from the ground up to the 5th story. The participant will then place the hose on the floor behind them.

The participant will then proceed to the 7th floor. Upon arrival on the roof, the participant must ring the bell and wave to proctor/Merit System staff below.

After accomplishing these tasks, the participant shall proceed down to the 5th floor and retrieve the 50ft section of 2 ½ -inch hose bundle and carry it down to the ground floor and exit the tower. The hose bundle will be placed on the ground in the designated area.

Tips:

When climbing the tower, use the handrail to pull yourself up, hold on to the rails on the way down. For the hose hoist, use the hand-over-hand technique. Do not let the rope slip. Do not allow both feet to leave the ground. Pull the rope behind you so that the rope does not get caught up while you are performing this function

Failure:

Failure to complete these evolutions as directed above will constitute a failure.

Skipping the hose hoist on the 5th floor

If the hoisted hose drops more than 5 feet while pulling it up

If the rope slides through hands

If both feet come off of the ground

If upper body bends past parallel with the hand rail on the balcony

If the participant wraps rope around hands/ body part or pulls rope by walking

Hoisting the rope/hose while stepping on rope to assist with stopping or holding rope

Participant may not go outside of the designated area while hoisting the hose.

Participant does not ring bell or look over edge to wave to proctor below

K-12 SAW OPERATION

Requirement:

Simulate the start and operation of a K-12 saw.

Job Relatedness:

Power equipment such as the K-12 saw is often used during fire fighting operations.

Procedure:

The participant shall place one hand on the safety bar and the other hand on the starter rope handle. The toe of one boot shall be placed into the footplate of the saw. The participant shall pull on the starter rope with sufficient force as to crank the K-12 saw. There shall be 5 attempts to start the K-12 saw by pulling the starter rope and then the saw can be placed into the rack hooks. The participant will then lower the K-12 saw as to simulate the cutting action then raise the saw

back up to the starting position. Remove the K-12 saw from the rack and safely place it back on the ground.

Tips:

Position your upper body over the center of the saw and pull with your shoulder not your back.

Failure:

Failure to pull the starter rope five (5) times and successfully rack and pull the saw.

This completes the Dekalb County Physical Ability Test. The allowable time to successfully pass is 20 minutes or less. If at any time during the test you feel nausea or acute discomfort in breathing or chest pain notify the Fire Academy personnel.

Additional Evolutions:

Aerial ladder Climb

Requirement:

Climb an aerial ladder.

Job Relatedness:

Personnel are often required to ascend an aerial ladder to aide in the extinguishment of fires.

Procedure:

Participant wearing gloves, helmet and shall be given a ladder belt of the appropriate size to be placed around the waist. Once prepared the participant shall climb onto the turntable of the aerial apparatus and begin to ascend the ladder. The ladder will be 100 foot in length, extended to an approximate 60-70 degree angle for climbing. Once at the designated ladder rung the participant will "lock in" the ladder belt and signal to the proctor located at the tip of the ladder. Once complete, the participant shall then "unlock" the ladder belt and descend the ladder until he/she reaches the ground.

The candidate will have five (5) minutes to complete the exercise.

Tips:

Do not look down towards the ground look only at the ladder rungs while climbing. Keep at least 3 points of contact with the ladder at all times.

Failure:

Failure to climb the ladder and "lock in" to the designated ladder rung
Failure to complete task in 5 minutes.

Crawl/Search Drill

Requirement:

Crawl through the search simulator.

Job Relatedness:

Firefighters often have to crawl through spaces in order to search for victims/ downed personnel. Staying low increases visibility and reduces heat exposure.

Procedure:

Participant shall enter the search simulator at the designated point and crawl through until he/she reaches the designated exit point.

Tips:

Crouch low while crawling and continue to move forward until exiting.

Failure:

Failure to complete the exercise and exit at the designated exit point

Failure to complete task in 5 minutes

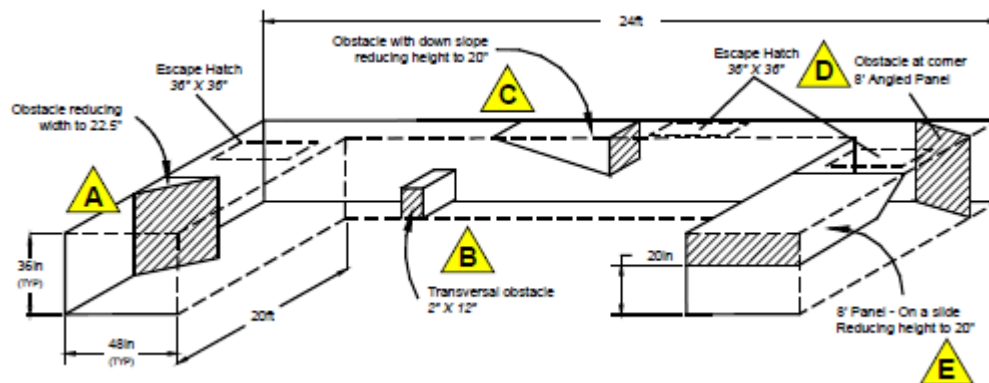

This completes the secondary portion of the DeKalb County Physical Ability Test. If at any time during the test you feel nausea or acute discomfort in breathing or chest pain notify the Fire Academy personnel.