



DeKalb County Government

Manuel J. Maloof Center
1300 Commerce Drive
Decatur, Georgia 30030

Agenda Item

File #: 2020-0836

9/24/2020

File Status: Preliminary Item

Public Hearing: YES NO

Department: Planning & Sustainability

SUBJECT:

COMMISSION DISTRICT(S): 1 & 7

Application of Embry Hills Church of Christ c/o Michelle Battle for a Special Land Use Permit (SLUP) to add a new 700-seat sanctuary and expand the parking lot to accommodate 243 parking spaces, at 3214 Chamblee-Tucker Road.

PETITION NO: N4. SLUP-20-1244110 2020-0836

PROPOSED USE: Enter Proposed Use.

LOCATION: 3214 Chamblee-Tucker Road

PARCEL NO. : 18-283-02-012, 18-284-04-007 & 18-284-04-008

INFO. CONTACT: Jeremy McNeil, Sr Planner

PHONE NUMBER: 404-371-2155

PURPOSE:

Application of Embry Hills Church of Christ c/o Michelle Battle for a Special Land Use Permit (SLUP) to add a new 700-seat sanctuary and expand the parking lot to accommodate 243 parking spaces. The property is located on the north side of Chamblee Tucker Road, approximately 150 feet east of North Embry Circle, at 3214, 3220, and 3250 Chamblee Tucker Road in Chamblee, Georgia. The property has approximately 811 feet of frontage along Chamblee Tucker Road and contains 5.8 acres.

RECOMMENDATION:

COMMUNITY COUNCIL: Full Cycle Deferral.

PLANNING COMMISSION: Full Cycle Deferral.

PLANNING STAFF: Full Cycle Deferral.

STAFF ANALYSIS: Based on the feedback from the neighboring property owners that attended the Community Council District 1 public meeting, there were concerns regarding the storm water run-off. Based on the submitted site plan and survey, there is steep topography that slopes to the north and west into the residential properties. The proposed renovated detention pond is located east of the existing church, the adjoining property owners raised concerns regarding the direction of the water flow. The applicant had mentioned that they were installing an underground system to capture the water, however, the adjoining

property owners preferred to see a visual of the water flow. Therefore, it is the recommendation of Planning and Sustainability Department that the Special Land Use Permit (SLUP) be “Deferred, Full Cycle to allow a hydrology study to be submitted”.

PLANNING COMMISSION VOTE: Full Cycle Deferral 7-0-0. P. Womack, Jr. moved, G. McCoy seconded for a “Full Cycle Deferral”. V. Moore was no longer present.

COMMUNITY COUNCIL VOTE/RECOMMENDATION: Full Cycle Deferral 4-0-0.



DeKalb County Department of Planning & Sustainability

**330 Ponce De Leon Avenue, Suite 300
Decatur, GA 30030
(404) 371-2155 / plandev@dekalbcountyga.gov**

Michael Thurmond
Chief Executive Officer

**Planning Commission Hearing Date: September 1, 2020
Board of Commissioners Hearing Date: September 24, 2020**

STAFF ANALYSIS

Case No.: SLUP-20-1244110 **Agenda #:** N.4

Location/Address: North side of Chamblee Tucker Road, approximately 150 feet east of North Embury Circle, at 3214, 3220, and 3250 Chamblee Tucker Road Chamblee, Georgia. **Commission District:** 01 **Super District:** 06

Parcel ID: 18-283-02-012; 18-284-04-007; and 18-284-04-008

Request: A Special Land Use Permit (SLUP) to add a new 700-seat sanctuary and expand the parking lot to accommodate 243 parking spaces.

Property Owner/Agent: Embury Hills Church of Christ

Applicant/Agent: Battle Law P.C.

Acreage: 5.80 acres

Existing Land Use: Place of worship and two detached single family structures.

Surrounding Properties/ Adjacent Zoning: **North:** R-100 (Residential Medium Lot-100) District; Detached Single Family Residences. **East:** NS (Neighborhood Shopping Commercial) District; *Asiklar Camisi (Masjid)*. **South:** R-100 (Residential Medium Lot-100) and RSM (Small Lot Residential Mix); Detached Single Family Residences and Muti-Family housing. **West:** R-100 (Residential Medium Lot) District; Detached Single Family Residences.

Comprehensive Plan: Commercial Redevelopment Corridor (CRC) Consistent Inconsistent

Proposed Density: N/A	Existing Density: N/A
Proposed Square Ft.: N/A	Existing Units/Square Feet: N/A
Proposed Lot Coverage: 57	Existing Lot Coverage: 39

SUBJECT PROPERTIES

The subject properties are located on the north side of Chamblee Tucker Road, approximately 150 feet east of North Embury Circle, at 3214, 3220, and 3250 Chamblee Tucker Road Chamblee, Georgia. All three sites combined contains approximately 5.80 acres with approximately 670 feet of frontage along Chamblee Tucker Road. The surrounding properties to the north are detached single family residences. The surrounding properties to the south across Chamblee Tucker Road are detached single-family residences and multi-family housing. The property west of the subject property is a detached single family residence. The subject property to the east is the location of *Asiklar Camisi (Masjid)*. The subject properties are zoned R-100 (Residential Medium Lot-100) District.

ZONING HISTORY AND ANALYSIS

The properties are currently zoned R-100 (Residential Medium Lot-100) District along the Chamblee Tucker road corridor. To the south of the site properties, across Chamblee Tucker Road, are R-100 (Residential Medium Lot-100) and RSM (Small Residential Lot Mix) zoned properties. To the north and west of the subject properties are R-100 (Residential Medium Lot-100) zoned properties. Directly east of the subject properties, is the NS (Neighborhood Shopping Commercial) zoning district.

PROJECT ANALYSIS

The applicant is requesting a Special Land Use Permit (SLUP) for the expansion of an existing place of worship. Based on the submitted materials, the applicant is proposing to demolish the three single family home buildings on the subject properties; expand the existing church building that will include a new sanctuary with 700 fixed seats; expand the parking lot area to provide for a total of 243 parking spaces at a ratio of 1 space for every 2.88 fixed seats; and enlarge the existing detention pond and install on-site water quality.

The submitted site plan depicts the existing place of worship with the proposed addition. The site plan also depicts 243 parking spaces along the western, eastern, and northern parts of the structure. Also, located east of the proposed structure is placement of the proposed renovated detention pond.

The existing sidewalk along Chamblee Tucker Road will be maintained to provide pedestrian access to the place of worship. The existing ingress and egress from Chamblee Tucker Road will also to be maintained for entry/exit for the place of worship.

This SLUP request is compatible with other surrounding uses along. The proposed expansion must comply with the following supplemental regulations per Sec.27- 4.2.42. of the DeKalb County Zoning Code:

- A. *Any building or structure established in connection with places of worship, monasteries or convents shall be located at least fifty (50) feet from any residentially zoned property. Where the adjoining property is zoned for nonresidential use, the setback for any building or structure shall be no less than twenty (20) feet for a side-yard and no less than thirty (30) feet for a rear-yard.*
- B. *The required setback from any street right-of-way shall be the front-yard setback for the applicable residential district.*

- C. *The parking areas and driveways for any such uses shall be located at least twenty (20) feet from any property line, with a visual screen, provided by a six-foot-high fence or sufficient vegetation established within that area.*
- D. *Places of worship, convents and monasteries shall be located on a minimum lot area of three (3) acres and shall have frontage of at least one hundred (100) feet along a public street.*
- E. *Places of worship, convents and monasteries shall be located only on a thoroughfare or arterial.*
- F. *Any uses, buildings or structures operated by a place of worship that are not specifically included within the definition of place of worship must fully comply with the applicable zoning district regulations, including, but not limited to, any requirement for a special land use permit.*

The proposed SLUP request does comply with all the supplemental regulations.

IMPACT ANALYSIS

Section 27-7.4.6 of the DeKalb County Code states that the following criteria shall be applied in evaluating and deciding any application for a Special Land Use Permit.

- A. Adequacy of the size of the site for the use contemplated and whether or not adequate land area is available for the proposed use including provision of all required yards, open space, off-street parking, and all other applicable requirements of the zoning district in which the use is proposed to be located:**

Located on 5.80 acres, adequate land area is available to for the proposed church expansion. All required yards, open space, and off-street parking are satisfied within the R-100 (Residential Medium Lot-100) District

- B. Compatibility of the proposed use with adjacent properties and land uses and with other properties and land uses in the district:**

The current use is compatible with the adjacent and surrounding properties.

- C. Adequacy of public services, public facilities, and utilities to serve the contemplated use:**

It appears that there are adequate public streets and services are available for the proposed church expansion.

- D. Adequacy of the public street on which the use is proposed to be located and whether or not there is sufficient traffic carrying capacity for the proposed use, so as not to unduly increase traffic or create congestion in the area:**

The Subject Property is located on Chamblee-Tucker Road which is classified as a “Minor Arterial” street and has adequate capacity to handle the volume of traffic generated by the proposed use.

- E. Whether or not existing land uses located along access routes to the site will be adversely affected by the character of the vehicles or the volume of traffic generated by the proposed use.**

The proposal will not adversely affect the character of the vehicles or the volume of traffic generated by the proposed use. Traffic generated by the subject property has already been absorbed and accommodated over the past years as a place of worship.

F. Adequacy of ingress and egress to the subject property and to all proposed buildings, structures, and uses thereon, with particular reference to pedestrian and automotive safety and convenience, traffic flow and control, and access in the event of fire or other emergency:

Based on the submitted site plan, there is one access point to the site with street frontage along Chamblee Tucker Road. Emergency vehicles can access the site safely from this one access point. According to the site plan, it appears traffic will flow in a circular pattern to access the drive-through lane and available parking spaces.

G. Whether or not the proposed use would create adverse impacts upon any adjoining land use by reason of noise, smoke, odor, dust, or vibration that would be generated by the proposed use:

The proposed church expansion should not create adverse impacts upon any adjoining land use by reason of noise, smoke, odor, dust or vibration.

H. Whether or not the proposed use would create adverse impacts upon any adjoining land use by reason of the hours of operation of the proposed use:

The hours of operation of the place of worship should not create adverse impacts upon adjoining land uses.

I. Whether or not the proposed use will create adverse impacts upon any adjoining land use by reason of the manner of operation of the proposed use.

The manner of operation for the proposed place of worship should not create adverse impacts upon adjoining land uses.

Whether or not the proposed use is otherwise consistent with the requirements of the zoning district classification in which the use is proposed to be located.

Places of Worship are a permitted use within the R-100 (Residential Medium Lot-100) District with a Special Land Use Permit (SLUP).

J. Whether or not the proposed use is consistent with the policies of the comprehensive plan.

The site is located within the Suburban Character Area (SUB) by the DeKalb County 2035 Comprehensive Plan, the proposed church expansion is consistent with the following area policies: The non-residential development in suburban areas shall be limited to small-scale convenience goods/services to meet the needs of the surrounding residents.

K. Whether or not the proposed use provides for all required buffer zones and transitional buffer zones where required by the regulations of the zoning district in which the use is proposed to be located.

The proposed church expansion will abut R-100 (Medium Residential Lot) District to the north and west. The applicant will provide a 20-foot transitional buffer.

L. Whether or not there is adequate provision of refuse and service areas.

Adequate provision of refuse areas will be provided on site.

M. Whether the length of time for which the special land use permit is granted should be limited in duration:

There does not appear to be any compelling reasons for limiting the duration of the requested Special Land Use Permit.

N. Whether or not the size, scale and massing of proposed buildings are appropriate in relation to the size of the subject property and in relation to the size, scale and massing of adjacent and nearby lots and buildings.

The proposed SLUP is compatible in size and massing of adjacent and nearby commercial buildings in the area.

O. Whether the proposed use will adversely affect historic buildings, sites, districts, or archaeological resources.

The proposed SLUP will not adversely affect historic buildings, sites, districts, or archaeological resources.

P. Whether the proposed use satisfies the requirements contained within the supplemental regulations for such special land use permit.

The proposed SLUP complies with all of the following supplemental regulations per Sec.27-4.2.42. of the DeKalb County Zoning Code:

- A. *Any building or structure established in connection with places of worship, monasteries or convents shall be located at least fifty (50) feet from any residentially zoned property. Where the adjoining property is zoned for nonresidential use, the setback for any building or structure shall be no less than twenty (20) feet for a side-yard and no less than thirty (30) feet for a rear-yard.*
- B. *The required setback from any street right-of-way shall be the front-yard setback for the applicable residential district.*
- C. *The parking areas and driveways for any such uses shall be located at least twenty (20) feet from any property line, with a visual screen, provided by a six-foot-high fence or sufficient vegetation established within that area.*
- D. *Places of worship, convents and monasteries shall be located on a minimum lot area of three (3) acres and shall have frontage of at least one hundred (100) feet along a public street.*
- E. *Places of worship, convents and monasteries shall be located only on a thoroughfare or arterial.*
- F. *Any uses, buildings or structures operated by a place of worship that are not specifically included within the definition of place of worship must fully comply with the applicable zoning district regulations, including, but not limited to, any requirement for a special land use permit.*

R. Whether or not the proposed use will create a negative shadow impact on any adjoining lot or building as a result of the proposed building height.

The proposed SLUP request does not create a negative shadow impact on any adjoining lot or building.

S. Whether the proposed use would be consistent with the needs of the neighborhood or the community as a whole, be compatible with the neighborhood, and would not be in conflict with the overall objective of the comprehensive plan.

The proposed SLUP request would be consistent with the needs of the neighborhood or the community as a whole, be compatible with the neighborhood, and would not be in conflict with the overall objective of the comprehensive plan.

COMPLIANCE WITH DISTRICT STANDARDS

The site zoned R-100 (Residential Medium Lot-100) District must comply with minimum development standards per Article 2 – Table 2.2 Residential Zoning Districts Dimensional Requirements of the DeKalb County Zoning Ordinance.

STANDARD	REQUIREMENT	PROPOSED	COMPLIANCE
LOT WIDTH (M)	MINIMUM OF 100 FEET ON A PUBLIC STREET FRONTAGE	627 FEET	YES
LOT AREA (M)	15,000 SQUARE FEET	252,648 SQUARE FEET	YES
LOT COVERAGE	Max. 35%	57%	No. A variance is required
FRONT BUILDING SETBACK	40 FEET	40 Feet	YES
SIDE BUILDING SETBACK	INTERIOR 10 FEET	INTERIOR 50 FEET	YES YES
REAR SETBACK	40 FEET	50 FEET	YES
HEIGHT	2 story / 35 FEET	2 stories	YES
OPEN SPACE	MINIMUM 20%	20%	YES
PARKING – ARTICLE 6	One (1) space for each four (4) seats in the largest assembly room (MIN). One (1) space for each two (2) seats in the largest assembly room (MAX).	243 SPACES	YES

STAFF RECOMMENDATION:

Based on the feedback from the neighboring property owners that attended the Community Council District 1 public meeting, there were concerns regarding the storm water run-off. Based on the submitted site plan and survey, there is steep topography that slopes to the north and west into the residential properties. The proposed renovated detention pond is located east of the existing church, the adjoining property owners raised concerns regarding the direction of the water flow. The applicant had mentioned that they were installing an underground system to capture the water, however, the adjoining property owners prefer to see a visual of the water flow. Therefore, it is the recommendation of Planning and Sustainability Department that the Special Land Use Permit (SLUP) to allow the expansion of the existing place of worship be **DEFERRED FULL CYCLE** with condition that a hydrology study is submitted.

Attachments:

1. Department and Division Comments
2. Application
3. Site Plan
4. Zoning Map and Land Use Map
5. Aerial Photograph/Site Photographs

N-4



DEKALB COUNTY GOVERNMENT PLANNING DEPARTMENT DISTRIBUTION FORM

**NOTE: PLEASE RETURN ALL COMMENTS VIA EMAIL OR FAX TO EXPEDITE THE PROCESS TO
MADOLYN SPANN MSPANN@DEKALBCOUNTYGA.GOV OR JOHN REID JREID@DEKALBCOUNTYGA.GOV**

COMMENTS FORM: PUBLIC WORKS TRAFFIC ENGINEERING

Case No.: SLUP-20-1244110 Parcel I.D. #: 18-283-.02-012

Address: 3214
Chamblee Tucker Rd
Chamblee, Ga

Adjacent Roadway (s):

(classification) (classification)

Capacity (TPD) _____	Capacity (TPD) _____
Latest Count (TPD) _____	Latest Count (TPD) _____
Hourly Capacity (VPH) _____	Hourly Capacity (VPH) _____
Peak Hour. Volume (VPH) _____	Peak Hour. Volume (VPH) _____
Existing number of traffic lanes _____	Existing number of traffic lanes _____
Existing right of way width _____	Existing right of way width _____
Proposed number of traffic lanes _____	Proposed number of traffic lanes _____
Proposed right of way width _____	Proposed right of way width _____

Please provide additional information relating to the following statement.

According to studies conducted by the Institute of Traffic Engineers (ITE) 6⁷TH Edition (whichever is applicable), churches generate an average of fifteen (15) vehicle trip end (VTE) per 1, 000 square feet of floor area, with an eight (8%) percent peak hour factor. Based on the above formula, the _____ square foot place of worship building would generate _____ vehicle trip ends, with approximately ____ peak hour vehicle trip ends.

Single Family residence, on the other hand, would generate ten (10) VTE's per day per dwelling unit, with a ten (10%) percent peak hour factor. Based on the above referenced formula, the ____ (Single Family Residential) District designation which allows a maximum of ____ units per acres, and the given fact that the project site is approximately ____ acres in land area, ____ daily vehicle trip end, and ____ peak hour vehicle trip end would be generated with residential development of the parcel.

COMMENTS:

Plans & field reviewed. Found nothing that
would interrupt traffic flow.

Signature: [Handwritten Signature]



DEKALB COUNTY GOVERNMENT PLANNING DEPARTMENT DISTRIBUTION FORM

The following areas below may warrant comments from the Development Division. Please respond accordingly as the issues relate to the proposed request and the site plan enclosed as it relates to Chapter 14. You may address applicable disciplines.

DEVELOPMENT ANALYSIS:

- **Transportation/Access/Row**

Consult the Georgia DOT as well as the DeKalb County Transportation Department prior to land development permit. Verify widths from the centerline of the roadways to the property line for possible right-of-way dedication. Improvements within the right-of-way may be required as a condition for land development application review approval. Safe vehicular circulation is required. Paved off-street parking is required.

- **Storm Water Management**

Compliance with the Georgia Stormwater Management Manual, DeKalb County Code of Ordinances 14-40 for Stormwater Management and 14-42 for Storm Water Quality Control, to include Runoff Reduction Volume where applicable is required as a condition of land development permit approval. Use Volume Three of the G.S.M.M. for best maintenance practices. Use the NOAA Atlas 14 Point Precipitation Data set specific to the site. Recommend Low Impact Development features/ Green Infrastructure be included in the proposed site design to protect as much as practicable the statewaters and special flood hazard areas.

- **Flood Hazard Area/Wetlands**

The presence of FEMA Flood Hazard Area was not indicated in the County G.I.S. mapping records for the site; and should be noted in the plans at the time of any land development permit application. Encroachment of flood hazard areas require compliance with Article IV of Chapter 14 and FEMA floodplain regulations.

- **Landscaping/Tree Preservation**

Landscaping and tree preservation plans for any building, or parking lot must comply with DeKalb County Code of Ordinances 14-39 as well as Chapter 27 Article 5 and are subject to approval from the County Arborist.

- **Tributary Buffer**

State water buffer was reflected in the G.I.S. records for the site. Typical state waters buffer have a 75' undisturbed stream buffer and land development within the undisturbed creek buffer is prohibited without a variance per DeKalb County Code of Ordinances 14-44.1.

- **Fire Safety**

Plans for land development permit must comply with Chapter 12 DeKalb County Code for fire protection and prevention.



DEKALB COUNTY GOVERNMENT
PLANNING DEPARTMENT
DISTRIBUTION FORM

NOTE: PLEASE RETURN ALL COMMENTS VIA EMAIL OR FAX TO EXPEDITE THE PROCESS TO MICHELLE M ALEXANDER mmalexander@dekalbcountyga.gov OR JOHN REID JREID@DEKALBCOUNTYGA.GOV

COMMENTS FORM:
PUBLIC WORKS WATER AND SEWER

Case No.: SLUP-20-1244110

Parcel I.D. #: 18-283-02-012; 18-284-04-007; and 18-284-04-008

Address: 3214, 3220, and 3250 Chamblee Tucker Road

Chamblee, Georgia

WATER:

Size of existing water main: 8" DI Water Main ^{MSO} (~~s~~adequate/inadequate)

Distance from property to nearest main: Adjacent to Property

Size of line required, if inadequate: N/A

SEWER:

Outfall Servicing Project: North Fork Peachtree Creek Basin

Is sewer adjacent to property: Yes (X) No () If no, distance to nearest line: _____

Water Treatment Facility: R M Clayton WTF () adequate () inadequate

Sewage Capacity; * (MGPD)

Current Flow: 127 (MGPD)

COMMENTS:

* Please note that the sewer capacity has not been reviewed or approved for this project. A Sewer Capacity Request (SCR) must be completed and submitted for review. This can be a lengthy process and should be addressed early in the process.

Signature: 



**DEKALB COUNTY GOVERNMENT
PLANNING DEPARTMENT
DISTRIBUTION FORM**

NOTE: PLEASE RETURN ALL COMMENTS VIA EMAIL OR FAX TO EXPEDITE THE PROCESS TO MICHELLE M ALEXANDER mmalexander@dekalbcountyga.gov OR JOHN REID JREID@DEKALBCOUNTYGA.GOV

**COMMENTS FORM:
PUBLIC WORKS WATER AND SEWER**

Case No.: Z-20-1244119

Parcel I.D. #: 18-050-12-005

Address: 1377 Scott Boulevard

Decatur, Georgia

WATER:

Size of existing water main: 8" DI Water Main *mso* (~~adequate~~/inadequate)

Distance from property to nearest main: Adjacent to Property

Size of line required, if inadequate: N/A

SEWER:

Outfall Servicing Project: South Fork Peachtree Creek Basin

Is sewer adjacent to property: Yes (X) No () If no, distance to nearest line: _____

Water Treatment Facility: R M Clayton WTF () adequate () inadequate

Sewage Capacity; * (MGPD)

Current Flow: 127 (MGPD)

COMMENTS:

<p>* Please note that the sewer capacity has not been reviewed or approved for this project. A Sewer Capacity Request (SCR) must be completed and submitted for review. This can be a lengthy process and should be addressed early in the process.</p>

Signature: *[Handwritten Signature]*

08/13/2020

To: Mr. John Reid, Senior Planner
From: Ryan Cira, Environmental Health Manager
Cc: Alan Gaines, Technical Services Manager
Re: Rezone Application Review

General Comments:

DeKalb County Health Regulations prohibit use of on-site sewage disposal systems for:

- multiple dwellings
- food service establishments
- hotels and motels
- commercial laundries
- funeral homes
- schools
- nursing care facilities
- personal care homes with more than six (6) clients
- child or adult day care facilities with more than six (6) clients
- residential facilities containing food service establishments

If proposal will use on-site sewage disposal, please contact the Land Use Section (404) 508-7900.

Any proposal, which will alter wastewater flow to an on-site sewage disposal system, must be reviewed by this office prior to construction.

This office must approve any proposed food service operation or swimming pool prior to starting construction.

Public health recommends the inclusion of sidewalks to continue a preexisting sidewalk network or begin a new sidewalk network. Sidewalks can provide safe and convenient pedestrian access to a community-oriented facility and access to adjacent facilities and neighborhoods.

For a public transportation route, there shall be a 5ft. sidewalk with a buffer between the sidewalk and the road. There shall be enough space next to sidewalk for bus shelter's concrete pad installation. Recommendation: Provide trash can with liner at each bus stop with bench and monitor for proper removal of waste.

Since DeKalb County is classified as a Zone 1 radon county, this office recommends the use of radon resistant construction.

Board of Health

New Cases:

- N.1 SLUP-20-12244105 2020-0833 / 18-111-03-018
2933 North Druid Hills Road, Atlanta, GA 30329
 - Please review general comments.
 - Septic system installed on location surrounding 2933 North Druid Hills. The location with septic system installed was 2814 North Druid Hills Road on 08/02/1963.

- N.2 LP-20-1244107 / 2020-0834 /18-196-04,18-196-04-033, 18-196-04-034, 18-196-04-035, 18-196-04-037, 18-196-04-038, 18-196-04-039, 18-196-04-040, 18-196-04-041
2814 Clairmont Road, Atlanta, GA 30329
 - Please review general comments.
 - Septic installed on property 2920 Clairmont Road on 04/07/1974 within the vicinity of property 2814 Clairmont.

- N.3 Z-20-1244108 / 2020-0835 / 18-196004-029, 18-196-04-033, 18-196-04-034, 18-196-04-035, 18-196-04-037, 18-196-04-038, 18-196-04-039, 18-196-04-040, 18-196-04-041
2814 Clairmont Road, Atlanta, GA 30329
 - Please review general comments.

- N.4 SLUP-20-1244110 / 2020-0836 / 18-283-02-012, 18-283-02-007, 18-283-02-008
3214 Chamblee-Tucker Road, Chamblee, GA 30341
 - Please review general comments.
 - Septic system installed on property 04/13/1961

- N.5 LP-20-1244114 / 2020-0837 / 16-252-02-002
8400 Pleasant Hill Way, Lithonia, GA 30058
 - Please review general comments.
 - Septic system installed on property near vicinity at 8406 Pleasant Hill Way

- N.6 Z-20-1244113 / 2020-0838 / 16-254-02-002
8400 Pleasant Hill Way, Lithonia, GA 30058
 - Please review general comments.

- N.7 Z-20-1244119 / 2020-0839 / 18-050-12-005
1377 Scott Blvd., Decatur, GA 30030
 - Please review general comments.



Board of Health

N.8 Z-20-1244120 / 2020-0840 / 15-201-07-001, 15-201-07-003, 15-201-07-004, 15-201-07-005, 15-201-07-007

3229 Memorial Drive, Decatur, GA 30032

- Septic system installed on in same vicinity. The location is 3232 Memorial Drive on 04/21/1970.
- Please review general comments.

N.9 TA-20-1244141 / 2020-0841 / 18-043-01-004

4900 Memorial Drive, Stone Mountain, GA 30083

- Please review general comments.
- Septic System installed on 09/11/1964 at property 4947 Memorial Drive.

DeKalb County Board of Health

445 Winn Way – Box 987

Decatur, GA 30031

404.294.3700 • www.dekalbhealth.net

DEPARTMENT OF PLANNING & SUSTAINABILITY

SPECIAL LAND USE PERMIT APPLICATION

Amendments will not be accepted after 5 working days after the filing date.

Date Received: _____ Application No.: _____

APPLICANT NAME: Embry Hills Church of Christ, Inc. c/o Battle Law, P. C.

Daytime Phone #: 404.601.7616 Fax #: 404.745.0045

Mailing Address: One West Court Square Suite 750 Decatur, GA 30030

E-mail: mlb@battlelawpc.com

OWNER NAME: Embry Hills Church of Christ, Inc. (If
more than one owner, attach contact information for each owner)

Daytime Phone #: 770.455.8412 Fax #: _____

Mailing Address: 3250 Chamble Tucker Road, Atlanta, GA 30341

E-mail: jjohnson@fg-inc.net

SUBJECT PROPERTY ADDRESS OR LOCATION: 3214,3220 & 3250 Chamblee-Tucker Road
Atlanta, DeKalb County, GA, 30341

District(s): 18 Land Lot(s): 283 & 284 Block(s): 02 & 04 Parcel(s): 012, 007 & 008

Acreage or Square Feet: +/-5.80 Commission District(s): 1 & 7 Existing Zoning: R-100

Proposed Special Land Use (SLUP): A SLUP for a Place of Worship pursuant to DeKalb County Zoning Ordinance

I hereby authorize the staff of the Planning and Development Department to inspect the property that is the subject of this application.

Owner: _____ Agent: **Signature of Applicant:** *Battle Law P.C.*
(Check One)

Printed Name of Applicant: Battle Law, P.C.

Notary Signature and Seal:

Janet Jennings





GENERAL NOTES

1. THIS PLAN IS THE PROPERTY OF GEO SURVEY, INC. AND IS NOT TO BE REPRODUCED OR TRANSMITTED IN ANY FORM OR BY ANY MEANS, ELECTRONIC OR MECHANICAL, INCLUDING PHOTOCOPYING, RECORDING, OR BY ANY INFORMATION STORAGE AND RETRIEVAL SYSTEM, WITHOUT THE WRITTEN PERMISSION OF GEO SURVEY, INC.
2. THE USER OF THIS PLAN SHALL BE RESPONSIBLE FOR OBTAINING ALL NECESSARY PERMITS FROM THE APPROPRIATE AGENCIES.
3. THE USER OF THIS PLAN SHALL BE RESPONSIBLE FOR OBTAINING ALL NECESSARY INFORMATION FROM THE APPROPRIATE AGENCIES.
4. THE USER OF THIS PLAN SHALL BE RESPONSIBLE FOR OBTAINING ALL NECESSARY INFORMATION FROM THE APPROPRIATE AGENCIES.
5. THE USER OF THIS PLAN SHALL BE RESPONSIBLE FOR OBTAINING ALL NECESSARY INFORMATION FROM THE APPROPRIATE AGENCIES.
6. THE USER OF THIS PLAN SHALL BE RESPONSIBLE FOR OBTAINING ALL NECESSARY INFORMATION FROM THE APPROPRIATE AGENCIES.
7. THE USER OF THIS PLAN SHALL BE RESPONSIBLE FOR OBTAINING ALL NECESSARY INFORMATION FROM THE APPROPRIATE AGENCIES.
8. THE USER OF THIS PLAN SHALL BE RESPONSIBLE FOR OBTAINING ALL NECESSARY INFORMATION FROM THE APPROPRIATE AGENCIES.

STATEMENT OF WORK

The purpose of this contract is to provide professional engineering services for the design and construction of the proposed site plan for the Babby Mills Church of Christ. The work includes site plan preparation, utility layout, and construction details.

PROFESSIONAL ENGINEER

Geosurvey, Inc.
 1501 River Street
 Memphis, TN 38103
 Phone: (901) 743-9900
 Fax: (901) 743-9902
 www.geosurvey.com
 License: 45293
 State of Tennessee

811
 Know what's below.
 Call before you dig.
 Dial 811
 Or Call 800-283-7411



UTILITY NOTES

1. ALL UTILITY LINES SHALL BE DEEPER THAN THE PROPOSED FOUNDATION.

2. ALL UTILITY LINES SHALL BE PROTECTED BY A MINIMUM OF 18" OF CONCRETE.

3. ALL UTILITY LINES SHALL BE PROTECTED BY A MINIMUM OF 18" OF CONCRETE.

4. ALL UTILITY LINES SHALL BE PROTECTED BY A MINIMUM OF 18" OF CONCRETE.

5. ALL UTILITY LINES SHALL BE PROTECTED BY A MINIMUM OF 18" OF CONCRETE.

LEGEND

SYMBOL	DESCRIPTION
[Symbol]	1" DIA. WATER MAIN
[Symbol]	1" DIA. SEWER
[Symbol]	1" DIA. GAS
[Symbol]	1" DIA. FIBER OPTIC
[Symbol]	1" DIA. CABLE TV
[Symbol]	1" DIA. TELEPHONE
[Symbol]	1" DIA. POWER
[Symbol]	1" DIA. LIGHTNING PROTECTION
[Symbol]	1" DIA. RAINWATER
[Symbol]	1" DIA. STORM SEWER
[Symbol]	1" DIA. DRAINAGE
[Symbol]	1" DIA. EROSION CONTROL
[Symbol]	1" DIA. VEGETATION
[Symbol]	1" DIA. BOUNDARY
[Symbol]	1" DIA. EASEMENT
[Symbol]	1" DIA. RIGHT OF WAY
[Symbol]	1" DIA. ADJACENT PROPERTY
[Symbol]	1" DIA. EXISTING BUILDING
[Symbol]	1" DIA. PROPOSED BUILDING
[Symbol]	1" DIA. DRIVEWAY
[Symbol]	1" DIA. WALKWAY
[Symbol]	1" DIA. LANDSCAPE
[Symbol]	1" DIA. FENCE
[Symbol]	1" DIA. GROUND SURFACE
[Symbol]	1" DIA. FINISHED GRADE
[Symbol]	1" DIA. PROPOSED GRADE
[Symbol]	1" DIA. ELEVATION
[Symbol]	1" DIA. NORTH ARROW



ALWAYS USE THE SURVEY

3214, 3220, & 3250 Chamblee Tucker Road
 FOR
Babby Mills Church Of Christ

DATE	DESCRIPTION	BY	SCALE
08/18/09	FINAL PLAN	JK	1" = 40'
08/18/09	CONSTRUCTION SET	JK	1" = 40'
08/18/09	ISSUE FOR BIDDING	JK	1" = 40'
08/18/09	ISSUE FOR CONSTRUCTION	JK	1" = 40'
08/18/09	ISSUE FOR RECORDS	JK	1" = 40'

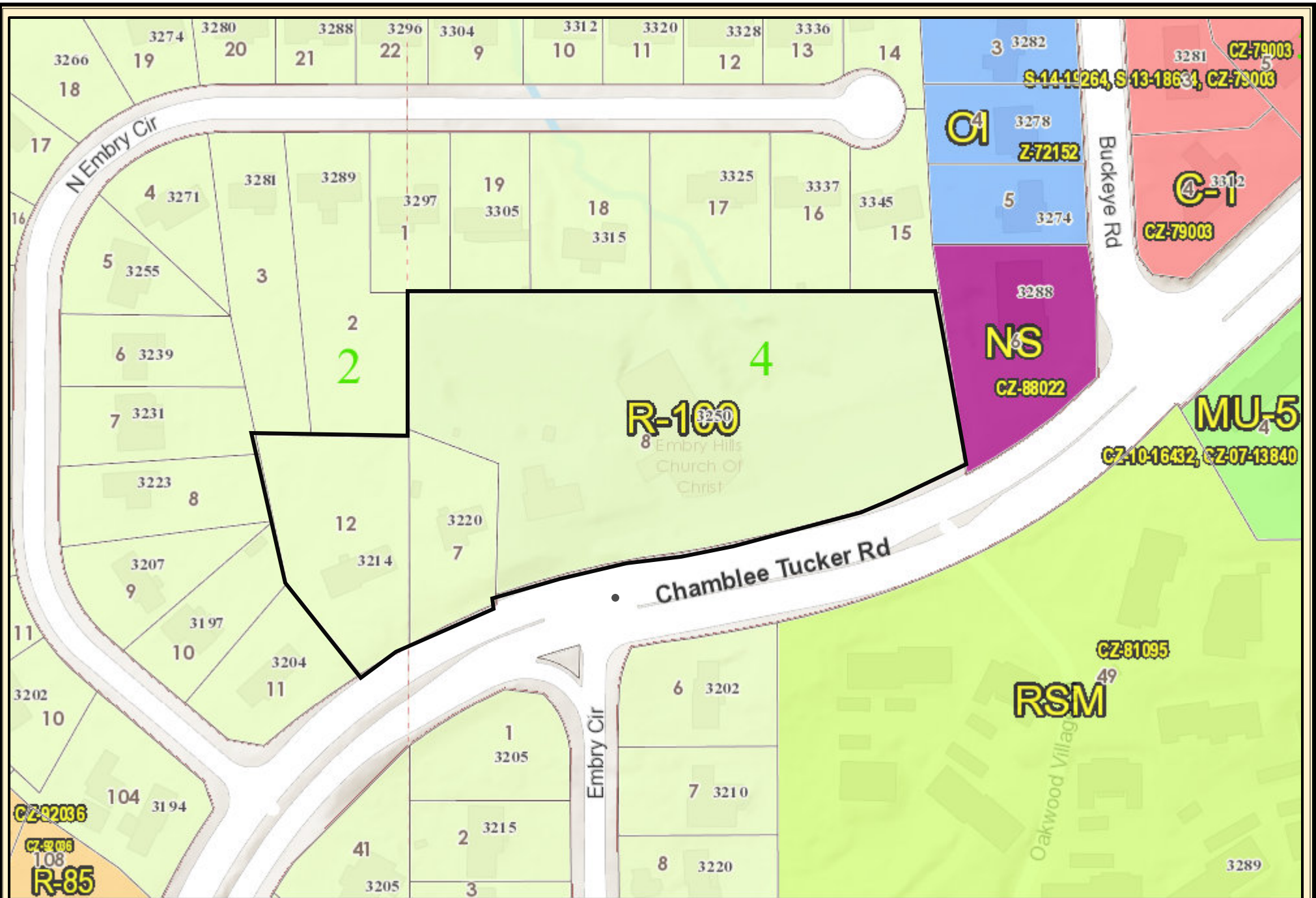

Zoning Map

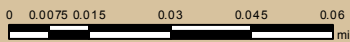

Date Printed: 8/6/2020



DeKalb County GIS Disclaimer

The maps and data, contained on DeKalb County's Geographic Information System (GIS) are subject to constant change. While DeKalb County strives to provide accurate and up-to-date information, the information is provided "as is" without warranty, representation or guarantee of any kind as to the content, sequence, accuracy, timeliness or completeness of any of the database information provided herein. DeKalb County explicitly disclaims all representations and warranties, including, without limitation, the implied warranties of merchantability and fitness for a particular purpose. In no event shall DeKalb County be liable for any special, indirect, or consequential damages whatsoever resulting from loss of use, data, or profits, whether in an action of contract, negligence, or other actions, arising out of or in connection with the use of the maps and/or data herein provided. The maps and data are for illustration purposes only and should not be relied upon for any reason. The maps and data are not suitable for site-specific decision-making nor should it be construed or used as a legal description. The areas depicted by maps and data are approximate, and are not necessarily accurate to surveying or engineering standards.

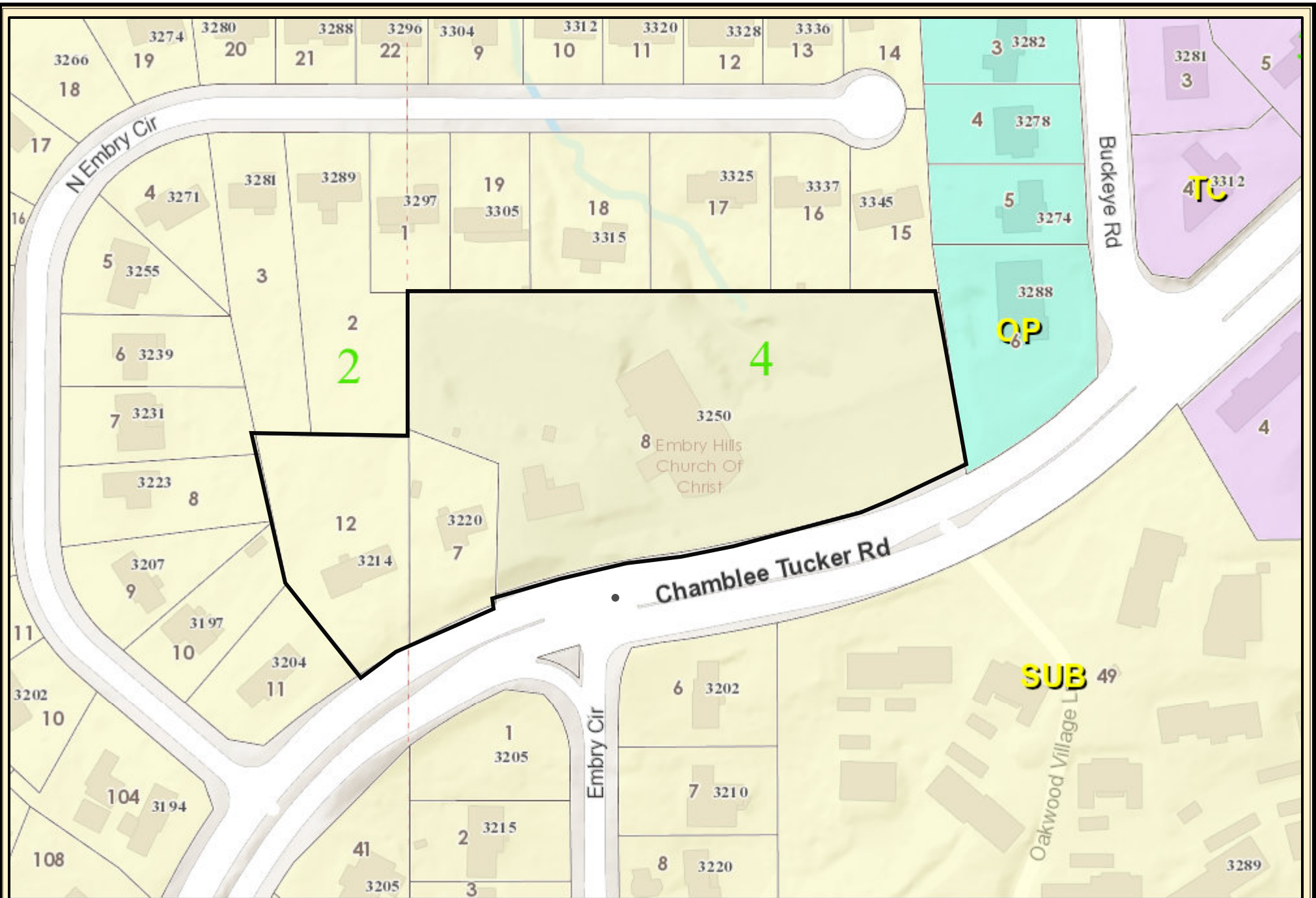

Future Land Use Map

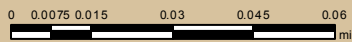

Date Printed: 8/6/2020



DeKalb County GIS Disclaimer

The maps and data, contained on DeKalb County's Geographic Information System (GIS) are subject to constant change. While DeKalb County strives to provide accurate and up-to-date information, the information is provided "as is" without warranty, representation or guarantee of any kind as to the content, sequence, accuracy, timeliness or completeness of any of the database information provided herein. DeKalb County explicitly disclaims all representations and warranties, including, without limitation, the implied warranties of merchantability and fitness for a particular purpose. In no event shall DeKalb County be liable for any special, indirect, or consequential damages whatsoever resulting from loss of use, data, or profits, whether in an action of contract, negligence, or other actions, arising out of or in connection with the use of the maps and/or data herein provided. The maps and data are for illustration purposes only and should not be relied upon for any reason. The maps and data are not suitable for site-specific decision-making nor should it be construed or used as a legal description. The areas depicted by maps and data are approximate, and are not necessarily accurate to surveying or engineering standards.

SITE PHOTOGRAPHS

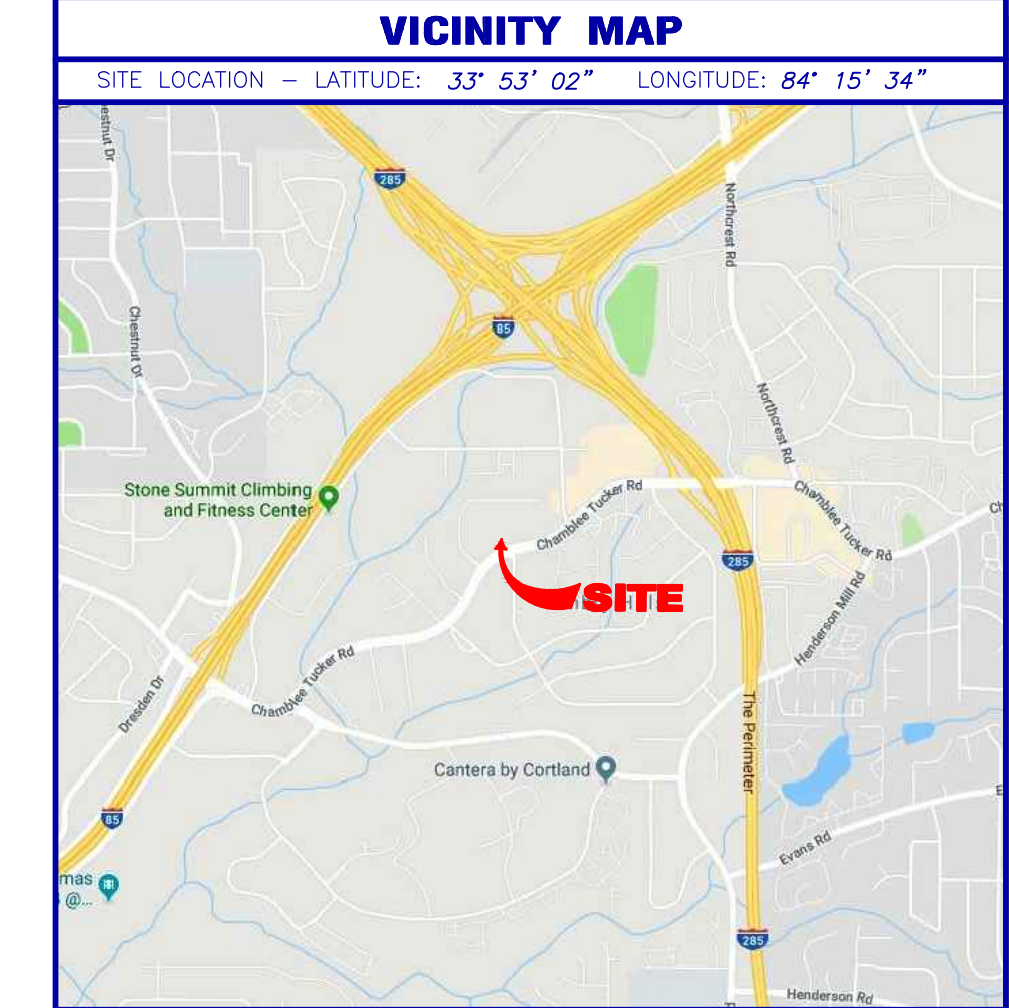

GENERAL NOTES

THIS SURVEY HAS BEEN PREPARED FOR THE EXCLUSIVE USE OF THE PERSON OR ENTITIES NAMED HEREON. NO EXPRESS OR IMPLIED WARRANTIES WITH RESPECT TO THE INFORMATION SHOWN HEREON IS TO BE EXTENDED TO ANY PERSONS OR ENTITIES OTHER THAN THOSE SHOWN HEREON.

THIS PROPERTY IS NOT LOCATED IN A SPECIAL FLOOD HAZARD AREA BASED ON THE FLOOD INSURANCE RATE MAP FOR THIS AREA. THE MAP NUMBER FOR THIS AREA IS 130880001R AND THE DATE OF SAID MAP IS AUGUST 15, 2015. THIS DETERMINATION WAS MADE BY GRAPHICALLY DETERMINING THE POSITION OF THIS SITE ON SAID FIRM MAPS UNLESS OTHERWISE NOTED.

PLEASE NOTE: TREES 6-INCH DBH (DIAMETER AT BREAST HEIGHT) AND LARGER WERE LOCATED FOR THIS SURVEY.

REVISIONS LISTED ON THIS SURVEY APPLY ONLY TO THE SPECIFIC CHANGES REFERENCED, AND DO NOT CONSTITUTE AN UPDATE OF OTHER DATA ON THIS SURVEY. THE "SURVEY DATE" SHOWN HEREON IS THE APPLICABLE DATE AS RELATED TO PROVISIONS OF STATUTES OF LIMITATION UNLESS SPECIFICALLY NOTED OTHERWISE.

RIGHT-OF-WAY LINES SHOWN ON THIS SURVEY THAT ARE NOT ACTUAL BOUNDARIES OF THE SUBJECT TRACT(S) ARE DEPICTED GRAPHICALLY AND ARE SHOWN APPROXIMATELY FOR INFORMATIONAL PURPOSES ONLY. SAID RIGHT-OF-WAY LINES SHOULD NOT BE UTILIZED FOR DESIGN PURPOSES.

THE DATUM FOR THIS SITE WAS ESTABLISHED UTILIZING GLOBAL POSITIONING SYSTEMS, AND BASED ON POSITIONAL VALUES FOR THE VIRTUAL REFERENCE STATION NETWORK DEVELOPED BY eGPS SOLUTIONS. THE HORIZONTAL REFERENCE FRAME IS NORTH AMERICAN DATUM OF 1983 (NAD83)-STATE PLANE COORDINATE SYSTEM OF GEORGIA-WEST ZONE. THE VERTICAL REFERENCE FRAME IS NORTH AMERICAN VERTICAL DATUM OF 1988. ANY DIRECTIONS OR DIMENSIONS SHOWN ARE A RECTANGULAR, GROUND LEVEL PROJECTION OF THE STATE PLANE COORDINATE SYSTEM.

NO ZONING REPORT OR ZONING LETTER WAS PROVIDED TO THE SURVEYOR. THE SITE IS ZONED "R-100" (RESIDENTIAL DISTRICT) AS SHOWN ON THE ZONING MAP OF DEKALB COUNTY. THE MINIMUM YARD SETBACKS ARE: FRONT (THOROUGHFARE) - 50 FEET; FRONT (ARTERIAL) - 40 FEET; FRONT (OTHER STREETS) - 35 FEET; SIDE - 10 FEET; REAR - 40 FEET.

PLEASE NOTE: ZONING AND SETBACKS SHOULD BE CONFIRMED AND VERIFIED BY PLANNING AND ZONING PRIOR TO DESIGN OR CONSTRUCTION ACTIVITIES.

SURVEY REFERENCES
1. GEORGIA DEPARTMENT OF TRANSPORTATION RIGHT OF WAY PLANS FOR CHAMBLEE-TUCKER ROAD WIDENING, PROJECT NUMBER IXAMR-286(5), P.L. NUMBER 751380

SURVEYOR CERTIFICATION (ALTA/NSPS)

To: Embry Hills Church of Christ
This is to certify that this map or plat and the survey on which it is based were made in accordance with the 2016 Minimum Standards Detail Requirements for ALTA/NSPS Land Title Surveys, jointly established and adopted by ALTA and NSPS, and includes Items 1, 2, 3, 4, 6(a), 7(a), 7(b-1), 8, 9, 10(a), 11, & 13 of Table A thereof. The field work was completed on June 6, 2019.

Date: June 6, 2019

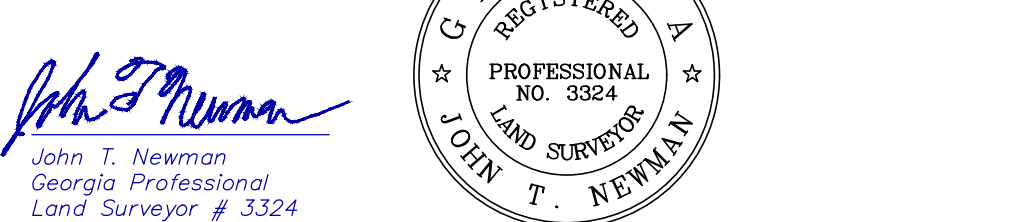

SURVEYOR CERTIFICATION (GEORGIA)

This plat is a retracement of an existing parcel or parcels of land and does not subdivide or create a new parcel or make any changes to any real property boundaries. The recording information of the documents, maps, plats, or other instruments which created the parcel or parcels are stated hereon. RECORDATION OF THIS PLAT DOES NOT IMPLY APPROVAL OF ANY LOCAL JURISDICTION. AVAILABILITY OF PERMITS, COMPLIANCE WITH LOCAL REGULATIONS OR REQUIREMENTS, OR SUITABILITY FOR ANY USE OR PURPOSE OF THE LAND. Furthermore, the undersigned land surveyor certifies that this plat complies with the minimum technical standards for property surveys in Georgia as set forth in the rules and regulations of the Georgia Board of Registration for Professional Engineers and Land Surveyors and as set forth in O.C.G.A. Section 15-6-67.



ALTA/NSPS LAND TITLE SURVEY

3214, 3220, & 3250 Chamblee Tucker Road			
FOR			
Embry Hills Church Of Christ			
ES JOB NO:	20196132	DRAWING SCALE:	1" = 40'
FIELD WORK:	CB/ZM	CITY:	UNINCORPORATED
PROJ MGR:	JTN	COUNTY:	DEKALB STATE: GA
REVIEWED:	JRC	LAND LOT:	283 & 284
DWG FILE:	20196132-02.dwg	DISTRICT:	18TH
SURVEY DATE:		06-06-2019	
REVISIONS (SEE GENERAL NOTES)			
No.	Date	Description	
1.	5-4-20	Add tracts 2 & 3	

(CLERK OF COURT RECORDING INFORMATION)

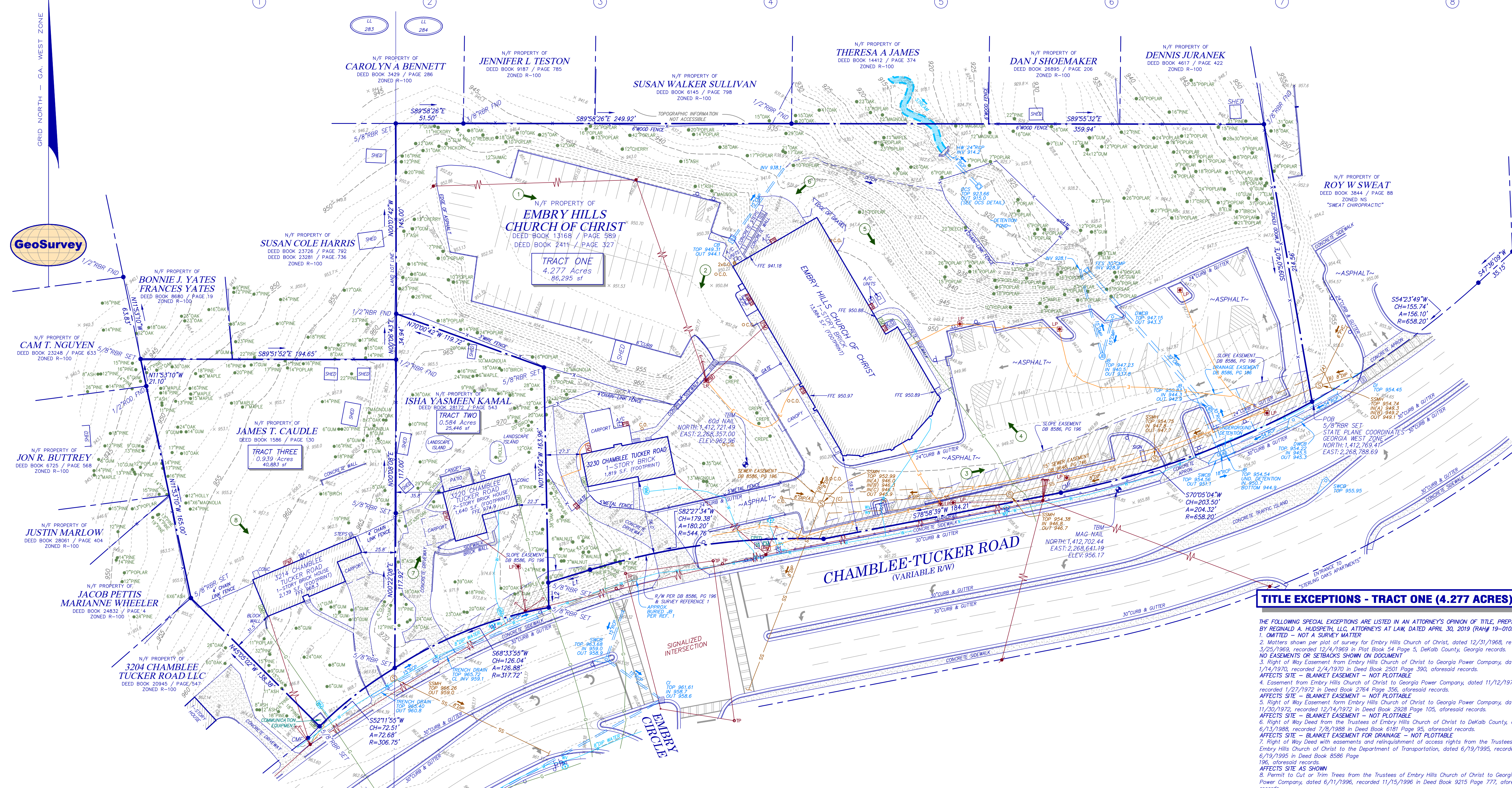

LINE TABLE

LINE	BEARING	DISTANCE
L1	S72°58'59"W	33.36'
L2	S01°09'42"E	18.95'

CLOSURE STATEMENT

THE FIELD CLOSURE UPON WHICH THIS PLAT IS BASED HAS A CLOSURE PRECISION OF ONE FOOT IN 23,152, AND WAS ADJUSTED USING THE LEAST SQUARES METHOD. A TRIMBLE S-6 TOTAL STATION AND TRIMBLE TSC-3 DATA COLLECTOR WERE USED TO COLLECT THIS FIELD DATA.
THIS PLAT HAS BEEN CALCULATED FOR CLOSURE AND WAS FOUND TO BE ACCURATE WITHIN ONE FOOT IN 111,289 FEET. *INTL. NIT.*

IF YOU DIG

811 Know what's below.
Call before you dig.
Dial 811
Or Call 800-282-7411

UTILITY NOTE

THE UNDERGROUND UTILITIES SHOWN HEREON ARE BASED ON LOCATION OF MARKINGS PROVIDED BY:
UTILISURVEY, LLC
1227 NORTH PEACHTREE PARKWAY, STE 178
PEACHTREE CITY, GA 30269

THE UNDERGROUND UTILITIES (EXCEPT THE LOCATION OF EXISTING DRAINAGE, SEWER AND IRRIGATION UTILITIES AS WELL AS UNDERGROUND STORAGE TANKS) WERE LOCATED BY UTILISURVEY, LLC, UTILIZING RADIO FREQUENCY TECHNIQUE. THIS TECHNIQUE IS CAPABLE OF LOCATING METALLIC UTILITIES AND TRACER WIRES. ANY NON-METALLIC UTILITIES (WITHOUT TRACER WIRE) ARE NOT LOCATED.

THE SURVEYOR MAKES NO GUARANTEES THAT THE UNDERGROUND UTILITIES SHOWN COMPRISE ALL SUCH UTILITIES IN THE AREA, EITHER IN-SERVICE OR ABANDONED, UNDERGROUND UTILITIES NOT OBSERVED OR LOCATED UTILIZING THIS TECHNIQUE MAY EXIST ON THIS SITE BUT NOT BE SHOWN, AND MAY BE FOUND UPON EXCAVATION. THE SURVEYOR FURTHER DOES NOT WARRANT THAT THE UNDERGROUND UTILITIES SHOWN ARE IN THE EXACT LOCATION INDICATED ALTHOUGH THE SURVEYOR DOES CERTIFY THAT THEY ARE LOCATED AS ACCURATELY AS POSSIBLE FROM INFORMATION AVAILABLE.

INFORMATION REGARDING MATERIAL AND SIZE OF UTILITIES IS BASED ON RECORDS ACQUIRED FROM THE UTILITY OWNERS.

OCS DETAIL

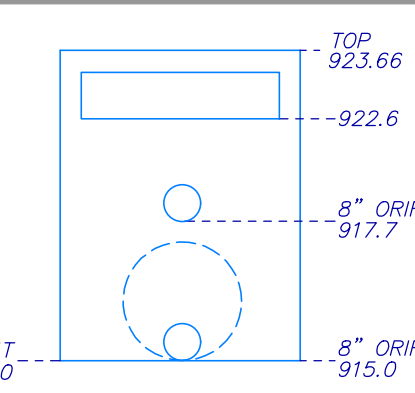

GRAPHIC SCALE

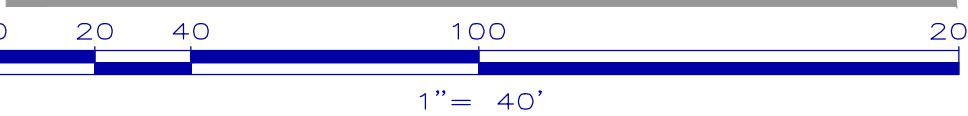

LEGEND

STANDARD ABBREVIATIONS	STANDARD SYMBOLS
AC AIR CONDITIONER	OVERHEAD TRAFFIC SIGNAL LIGHT
BH BORE HOLE	POWER POLE
BSL BUILDING SETBACK LINE	GUY WIRE
CI CURB INLET	POWER LINE
CMF CORRUGATED METAL PIPE	LIGHT POLE
CO CONCRETE MONUMENT FND	ELECTRIC TRANSFORMER
CP COMMUNICATION PEDESTAL	WATER VAULT
CPED CRIMPED TOP PIPE	GAS VALVE
DI DUCTILE IRON PIPE	GAS METER
DWCB DOUBLE WING CATCH BASIN	WATER VALVE
FN FOUND	WATER METER
GM GAS METER	FIRE HYDRANT
INV INVERT	UNDERGROUND ELECTRIC LINE
JM JUNCTION BOX	UNDERGROUND GAS LINE
MH MANHOLE	UNDERGROUND WATER LINE
OC OUTLET CONTROL STRUCTURE	PHOTO POSITION INDICATOR
OTP OPEN TOP PIPE	REGULAR PARKING SPACE COUNT
PKS PK NAIL SET	HANDICAP PARKING SPACE
PM POWER METER	TREE POSITION INDICATOR
PMB POINT OF BEGINNING	
PCC POINT OF COMMENCEMENT	
RCP REINFORCED CONCRETE PIPE	
RR IRON REINFORCING BAR	
RBC 5/8" BSR SET CAPPED LSF 621	
SS SANITARY SEWER	
SWS SINGLE WING CATCH BASIN	
TRANS ELECTRIC TRANSFORMER	

© Copyright 2018 by Croft & Associates, PC. All rights reserved. This document is property of Croft & Associates, PC. It is to be used only for the specific project referred to or identified herein and is not to be used on other projects, in whole or in part, except by the express written agreement of Croft & Associates, PC.

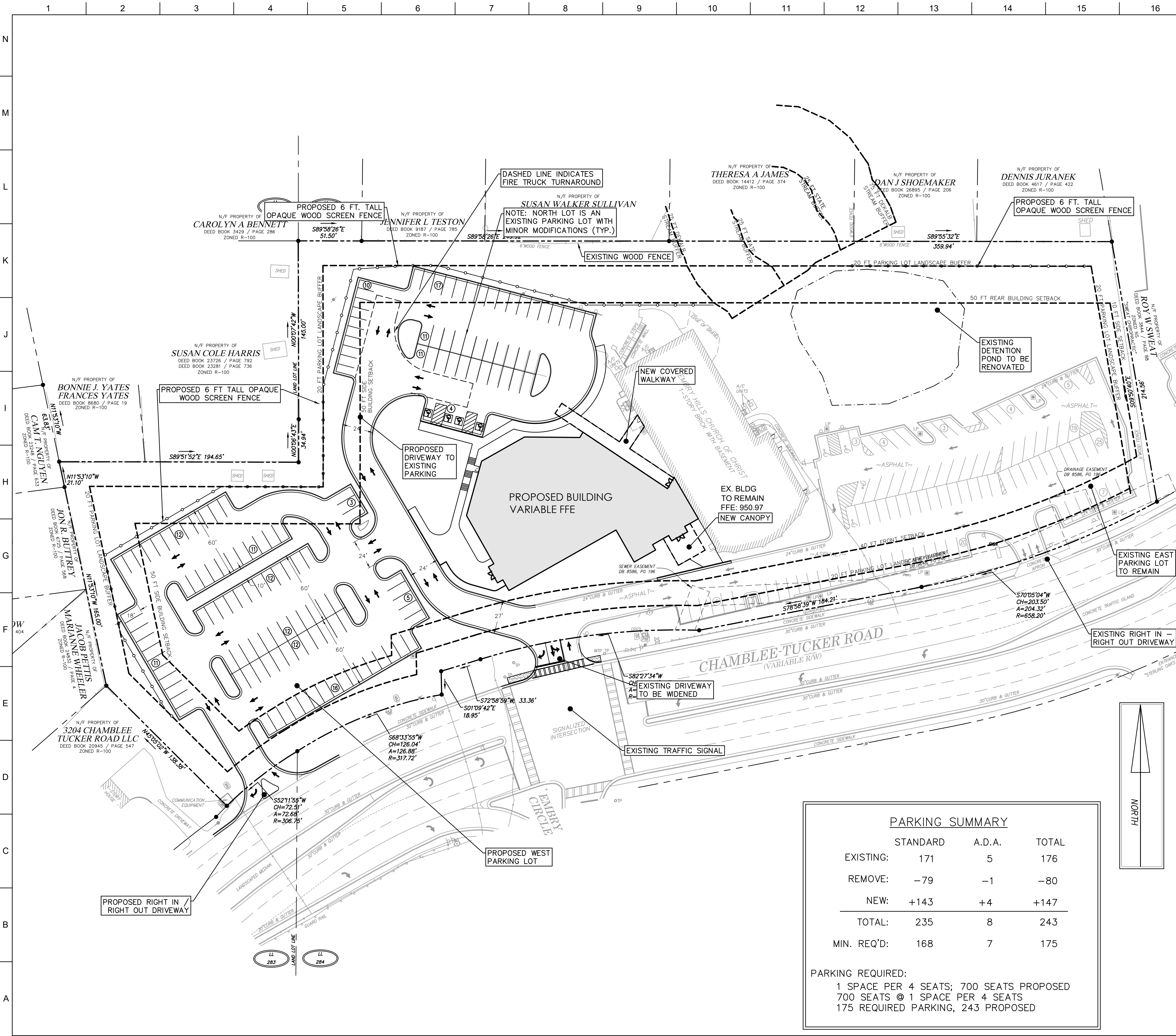

PROJECT DATA	
OWNER/DEVELOPER:	EMBRY HILLS CHURCH OF CHRIST 3250 CHAMBLEE-TUCKER RD ATLANTA, GA 30341
ARCHITECT:	CROFT & ASSOCIATES 3400 BLUE SPRINGS RD, STE 200 KENNESAW, GA 30144
CIVIL SITE ENGINEER:	CORNERSTONE SITE CONSULTANTS, LLC 2985 GORDY PKWY, SUITE 117 MARIETTA, GA 30066 ANDREW M. HALLORAN, P.E., PH: 770-490-9182
SITE ADDRESS:	3250 CHAMBLEE-TUCKER RD ATLANTA, GA 30341
SITE AREA:	5.80 ACRES
EXISTING SITE USE:	PLACE OF WORSHIP
PROPOSED PROJECT:	PLACE OF WORSHIP CAMPUS EXPANSION
SITE ZONING:	R-100
LOT COVERAGE AREA:	35% MAX ALLOWED 1.83 ACRES 43% (EXISTING) 3.20 ACRES 55% (PROPOSED)
OPEN SPACE:	20% MIN. REQUIRED 45% PROPOSED

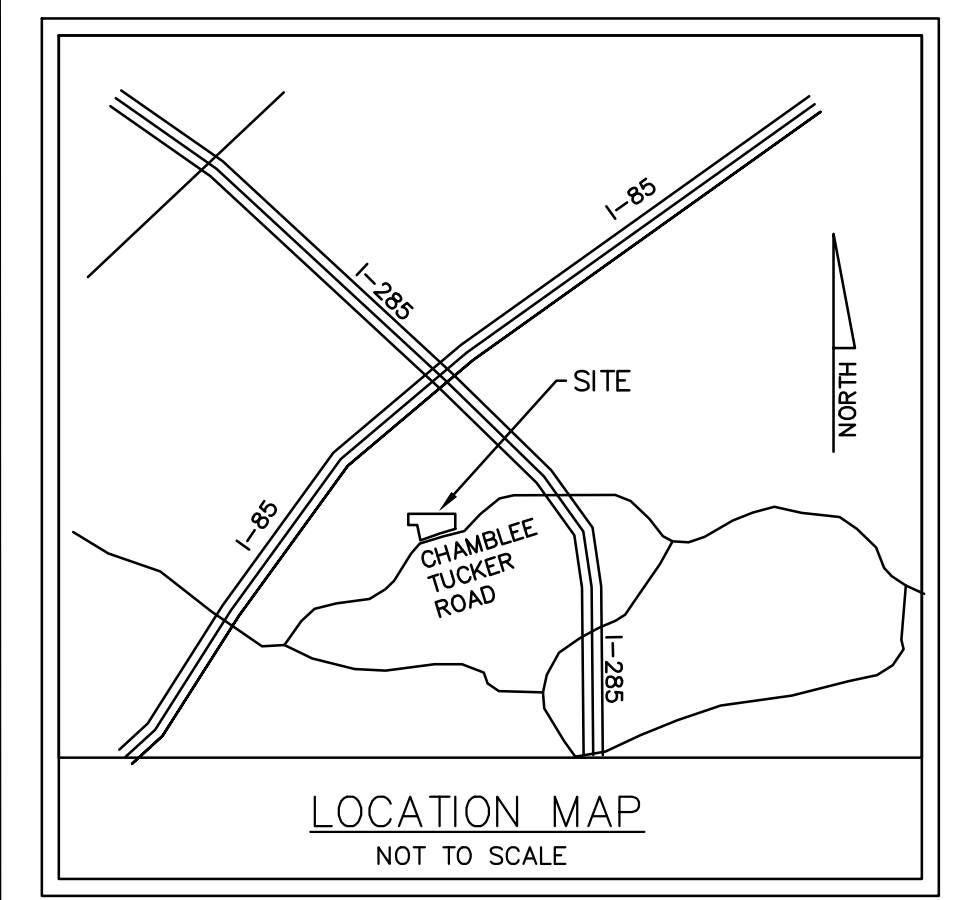

- REFERENCES**
- BOUNDARY, TOPOGRAPHIC, TREE AND UTILITY SURVEY INFORMATION BASED ON A SURVEY FOR EMBRY HILLS CHURCH OF CHRIST BY GEOSURVEY, INC. DATED 06-06-2019, LAST REVISED 05-04-2020.
 - THE FLOOD INSURANCE RATE MAP INDICATES AS PER OFFICIAL F.I.R.M. MAP 13089 C 0019J. THE SITE IS NOT IN ANY SPECIAL FLOOD HAZARD ZONE, DATED 5-16-2013

PARKING SUMMARY			
	STANDARD	A.D.A.	TOTAL
EXISTING:	171	5	176
REMOVE:	-79	-1	-80
NEW:	+143	+4	+147
TOTAL:	235	8	243
MIN. REQ'D:	168	7	175

PARKING REQUIRED:
 1 SPACE PER 4 SEATS; 700 SEATS PROPOSED
 700 SEATS @ 1 SPACE PER 4 SEATS
 175 REQUIRED PARKING, 243 PROPOSED

NOTE: CONCEPT PLAN IS PRELIMINARY IN NATURE, IT IS FOR INITIAL PLANNING PURPOSES ONLY AND SUBJECT TO CHANGE FROM DUE DILIGENCE, SURVEYS, DESIGN AND PERMIT APPROVALS THAT ARE NECESSARY AND REQUIRED.

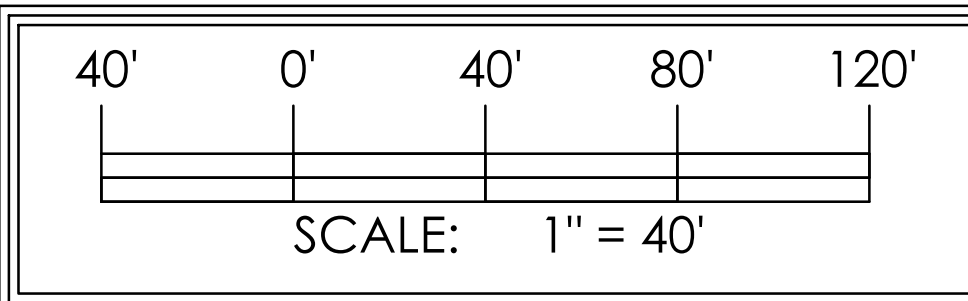

Croft & Associates
 3400 Blue Springs Road, Suite 200
 Kennesaw, Georgia 30144
 770.529.7714 (p) 770.529.7716 (f)
 www.croftae.com



Cornerstone Site Consultants, LLC
 2985 Gordy Parkway, Suite 117
 Marietta, GA 30066
 CSC Project # 2019-0020

OWNER
 EMBRY HILLS CHURCH OF CHRIST
 3250 CHAMBLEE-TUCKER ROAD
 ATLANTA, GA 30341

EMBRY HILLS CHURCH OF CHRIST RENOVATION / ADDITION
 ATLANTA, GA

No.	Date	Description
06-30-20		S.L.U.P. SUBMITTAL
		ISSUANCE

PROJECT NUMBER: _____
 DRAWN: APB CHECKED: AMH

SHEET TITLE:
S.L.U.P. CONCEPT SITE PLAN
 SHEET NO.

C-1

© Copyright 2018 by Croft & Associates, PC. All rights reserved. This document is property of Croft & Associates, PC. It is to be used only for the specific project referred to or identified herein and is not to be used on other projects, in whole or in part, except by the express written agreement of Croft & Associates, PC.

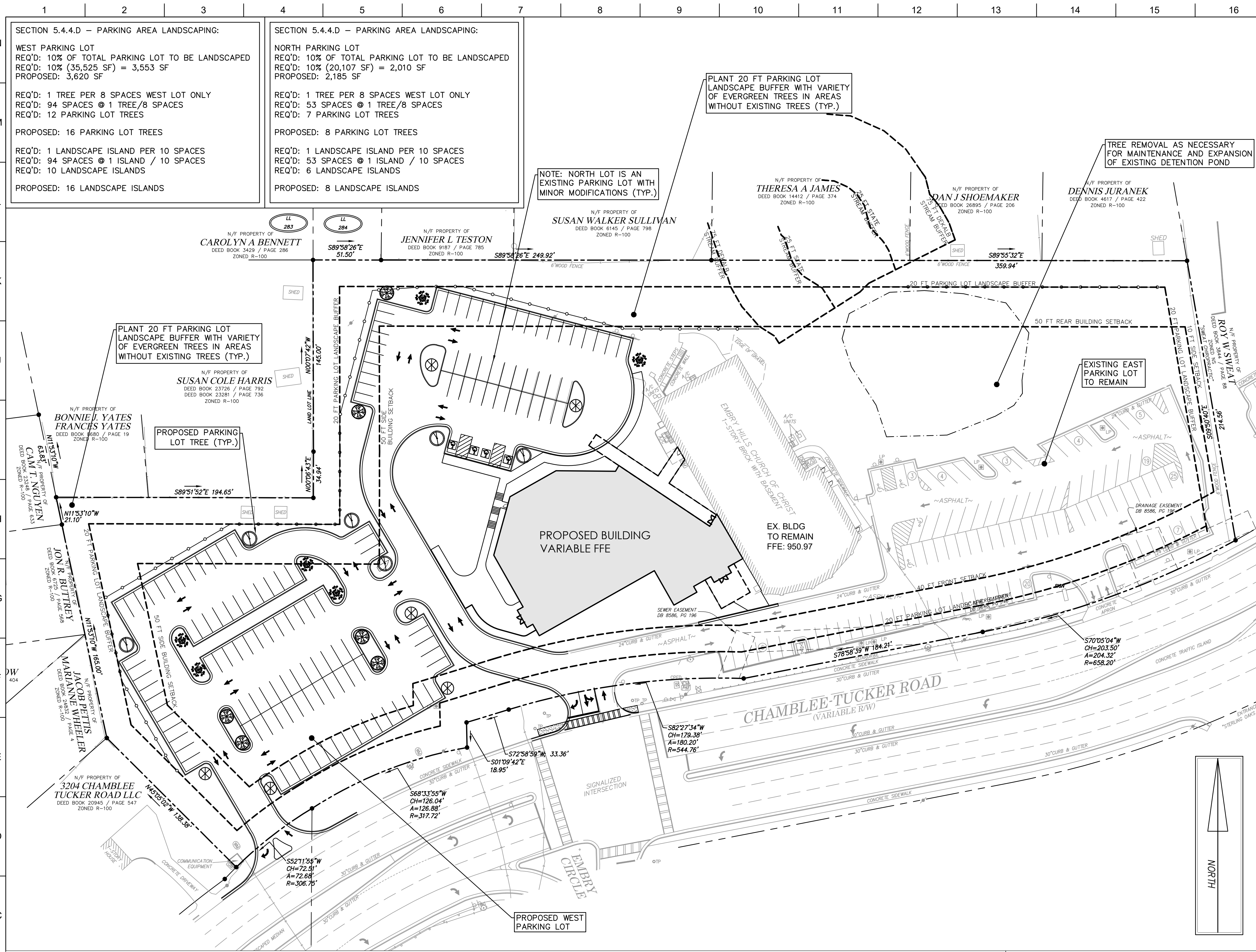

PROJECT DATA	
OWNER/DEVELOPER:	EMBRY HILLS CHURCH OF CHRIST 3250 CHAMBLEE-TUCKER RD ATLANTA, GA 30341
ARCHITECT:	CROFT & ASSOCIATES 3400 BLUE SPRINGS RD, STE 200 KENNESAW, GA 30144
CIVIL SITE ENGINEER:	CORNERSTONE SITE CONSULTANTS, LLC 2985 GORDY PKWY, SUITE 117 MARIETTA, GA 30066 ANDREW M. HALLORAN, P.E., PH: 770-490-9182
SITE ADDRESS:	3250 CHAMBLEE-TUCKER RD ATLANTA, GA 30341
SITE AREA:	5.80 ACRES
EXISTING SITE USE:	PLACE OF WORSHIP
PROPOSED PROJECT:	PLACE OF WORSHIP CAMPUS EXPANSION
SITE ZONING:	R-100
LOT COVERAGE AREA:	35% MAX ALLOWED 1.83 ACRES 43% (EXISTING) 3.20 ACRES 55% (PROPOSED)
OPEN SPACE:	20% MIN. REQUIRED 45% PROPOSED

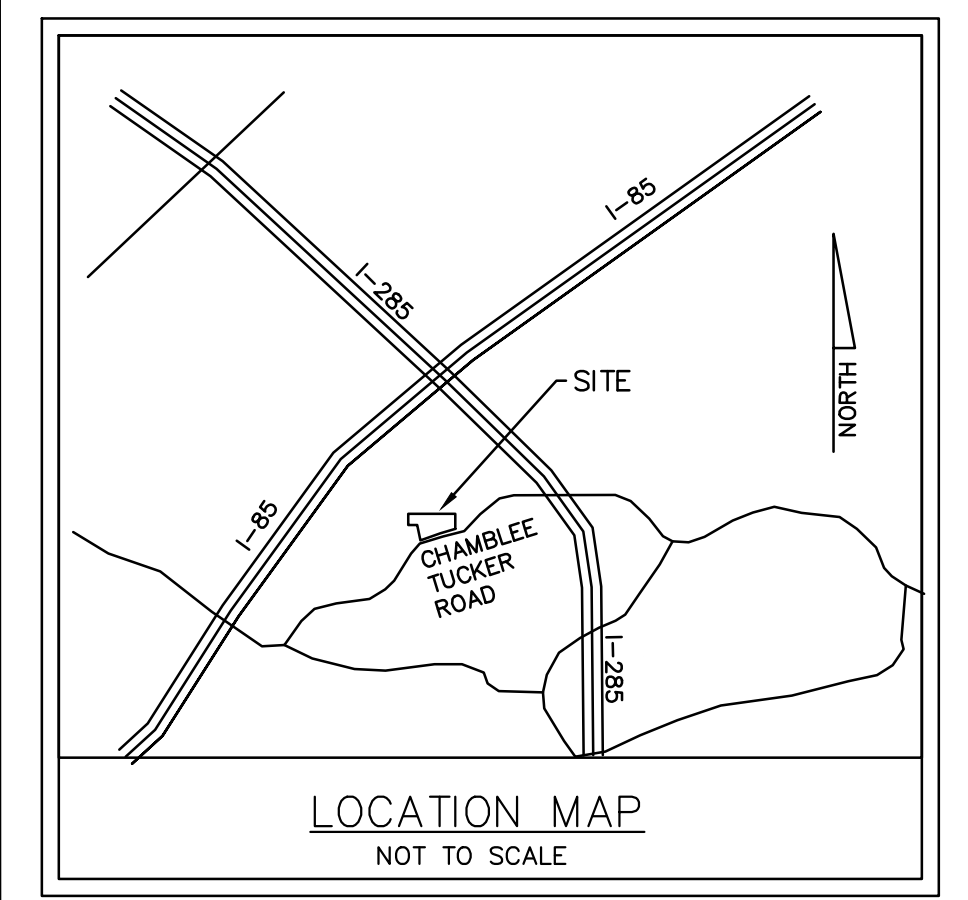

- REFERENCES
- BOUNDARY, TOPOGRAPHIC, TREE AND UTILITY SURVEY INFORMATION BASED ON A SURVEY FOR EMBRY HILLS CHURCH OF CHRIST BY GEOSURVEY, INC. DATED 06-06-2019, LAST REVISED 05-04-2020.
 - THE FLOOD INSURANCE RATE MAP INDICATES AS PER OFFICIAL F.I.R.M. MAP 13089 C 0019J. THE SITE IS NOT IN ANY SPECIAL FLOOD HAZARD ZONE, DATED 5-16-2013

NOTE: CONCEPT PLAN IS PRELIMINARY IN NATURE, IT IS FOR INITIAL PLANNING PURPOSES ONLY AND SUBJECT TO CHANGE FROM DUE DILIGENCE, SURVEYS, DESIGN AND PERMIT APPROVALS THAT ARE NECESSARY AND REQUIRED.

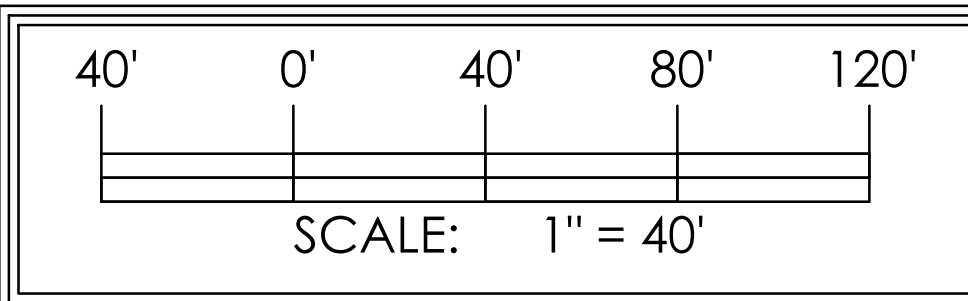

PROPOSED PLANT LIST									
SYMBOL	COMMON NAME	BOTANICAL NAME	NO. OF TREES	NO. OF TREE ORDINANCE TREES*	MINIMUM TREE SIZE	UNITS PER TREE	TOTAL UNITS	TOTAL TREE ORDINANCE UNITS**	% TREE ORDINANCE UNITS***
	RED MAPLE - "OCTOBER GLORY"	ACER RUBRUM	6	6	2 - 2.5" CAL.	0.4	2.4	2.4	25%
	ALLEE ELM	ULMUS PARVIFOLIA 'ALLEE'	6	6	2 - 2.5" CAL.	0.4	2.4	2.4	25%
	WILLOW OAK	QUERCUS PHELLOS	6	6	2 - 2.5" CAL.	0.4	2.4	2.4	25%
	TULIP POPLAR	LIRIODENDRON TULIPIFERA	6	6	2 - 2.5" CAL.	0.4	2.4	2.4	25%
TOTAL=			24				9.6		100%

DEKALB COUNTY TREE CALCULATIONS

TREE PRESERVATION - CODE 14.39(G)1:
 REQ'D = 5.80 AC x 120 INCHES
 REQ'D = 696 INCHES
 PROPOSED = 780 INCHES OF EX. TREES TO REMAIN

TREE DENSITY - CODE 14.39(G)3:
 REQ'D = 30 TREE UNITS/ AC @ 5.80 ACRES
 REQ'D = 174 TREE UNITS
 PROPOSED = 264 EX. TREE UNITS TO REMAIN THEREFORE DENSITY MET

* NUMBER OF TREES WHICH CAN BE COUNTED TOWARD MEETING TREE ORDINANCE REQUIREMENTS (AFTER GENUS CAP); ** NUMBER OF UNITS WHICH CAN BE COUNTED TOWARD MEETING TREE ORDINANCE REQUIREMENTS (AFTER GENUS CAP); *** PERCENT OF TREE ORDINANCE UNITS PER TREE SPECIES TO TOTAL TREE ORDINANCE UNITS



Croft & Associates
 3400 Blue Springs Road, Suite 200
 Kennesaw, Georgia 30144
 770.529.7714 (p) 770.529.7716 (f)
 www.croftae.com



Cornerstone Site Consultants, LLC
 2985 Gordy Parkway, Suite 117
 Marietta, GA 30066
 CSC Project # 2019-0020

OWNER
EMBRY HILLS CHURCH OF CHRIST
 3250 CHAMBLEE-TUCKER ROAD
 ATLANTA, GA 30341

EMBRY HILLS CHURCH OF CHRIST RENOVATION / ADDITION
 ATLANTA, GA

No.	Date	Description
06-30-20		S.L.U.P. SUBMITTAL
		ISSUANCE

PROJECT NUMBER
 DRAWN: APB CHECKED: AMH

SHEET TITLE
S.L.U.P. TREE PLAN

SHEET NO.
T-1

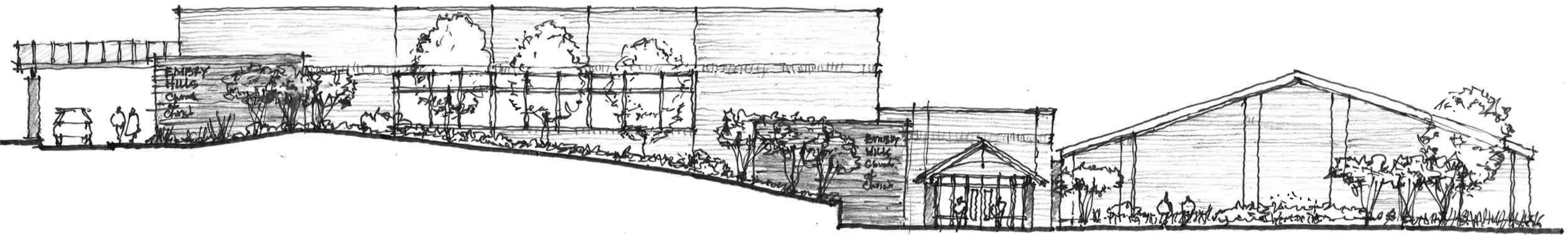

NEW SANCTUARY

NEW
ENTRY
CONNECTOR

EXISTING

Conceptual Elevation Chamblee-Tucker Road • EMERY HILLS CHURCH OF CHRIST 0.26.2020